

MONTAGEANLEITUNG

ASSEMBLY INSTRUCTIONS

NOTICE DE MONTAGE

MONTAGEHANDLEIDING

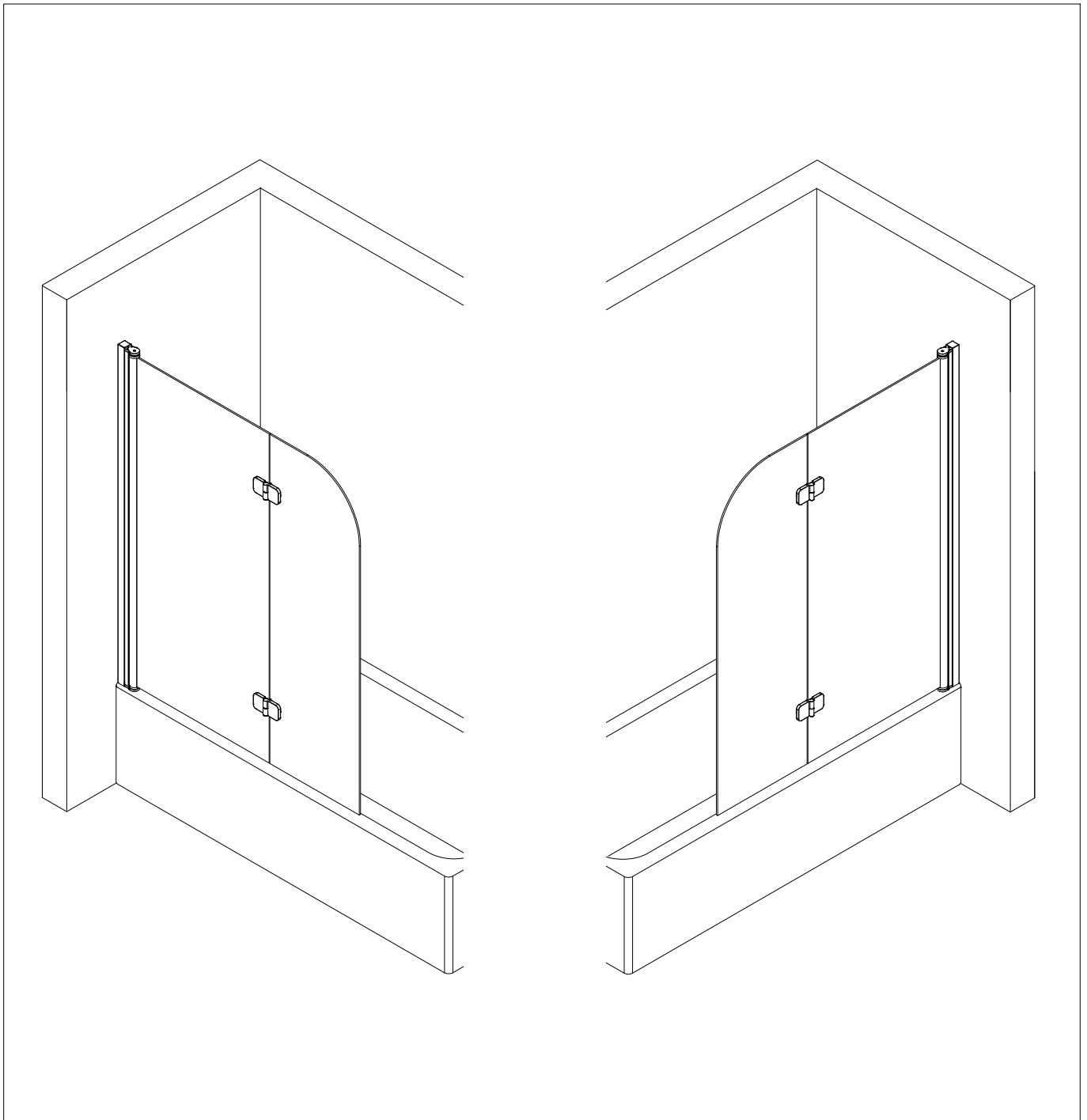



SICHERHEITSHINWEISE / SAFETY INSTRUCTIONS CONSEILS DE SÉCURITÉ / VEILIGHEIDSAANWIJZINGEN



de Glaskanten schützen

en Protect glass edges

fr Protégez les bords du verre

nl Glasranden beschermen

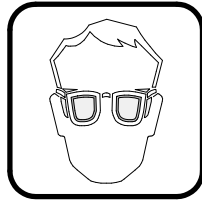

de Schutzbrille tragen

en Wear safety goggles

fr Portez des lunettes de protection

nl Veiligheidsbril dragen

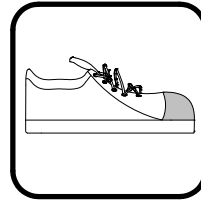

de Sicherheitsschuhe tragen

en Wear safety shoes

fr Portez des chaussures de sécurité

nl Veiligheidsschoenen dragen

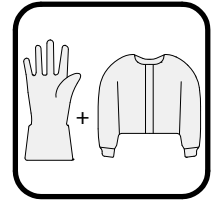

de Lange Handschuhe und langärmelige Kleidung tragen

en Wear long gloves and long-sleeved clothing

fr Portez des gants longs et des vêtements à manches longues

nl Draag lange handschoenen en kleding met lange mouwen



de Decken im Arbeitsbereich und dessen Umfeld auslegen

en Cover the shower tray and its area completely

fr Couvrez complètement le bac de douche et ses environs

nl Dekens op de douchebak en de omgeving leggen

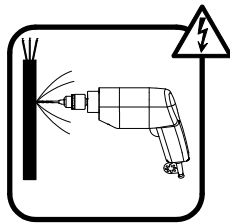

de Über die Lage der Stromleitung informieren

en Get information about the location of the power line

fr Informez-vous sur l'emplacement de la ligne électrique

nl Informeren over de locatie van de hoogspanningslijn

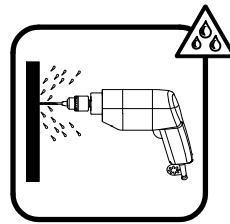

de Über die Lage der Wasserleitung informieren

en Get information about the location of the water pipe

fr Informez-vous sur l'emplacement de la ligne d'eau

nl Informeren over de locatie van de waterleiding

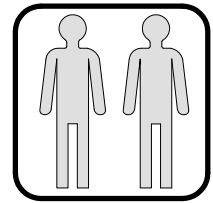

de Empfohlene Montage mit 2 Personen.

en Assembly recommended with 2 persons

fr Montage recommandé avec 2 personnes

nl Aanbevolen montage met 2 personen

HINWEIS / NOTE / NOTE / NOOT

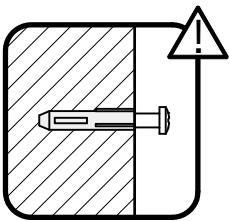

de Vor der Montage die Beschaffenheit des Mauerwerks überprüfen. Gegebenenfalls ist das im Lieferumfang enthaltene Befestigungsmaterial nicht für die Befestigung geeignet.

en Check the condition of the masonry before installation. If applicable, the fixing material included in the scope of delivery is not suitable for mounting.

fr Vérifiez l'état de la maçonnerie avant le montage. Le cas échéant, le matériel d'approvisionnement compris dans la livraison n'est pas adapté à la fixation.

nl Controleer de toestand van het metselwerk voor de installatie. Indien gewenst is het bij de levering inbegrepen bevestigingsmateriaal niet geschikt voor montage.

de Die Aufstellfläche der Duschkabine muss eben sein.

en The installation surface of the shower enclosure must be level.

fr La surface d'installation de la cabine de douche doit être plane.

nl Het montagevlak van de douchewand moet waterpas zijn.

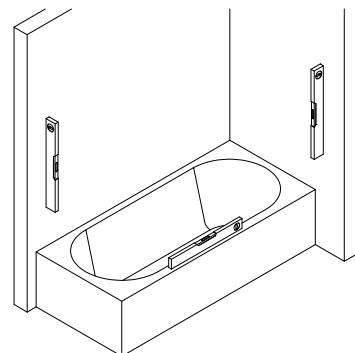

AUFBAUART / ASSEMBLY SITUATION / TYPE DE MONTAGE / ASSEMBLAGE SITUATIE

de Bei der Montage der Duschkabine gibt es zwei Aufbauarten: Aufbau **a** und **b**
In dieser Montageanleitung wird der Aufbau **a** dargestellt. Die Montageschritte für den Aufbau **b** sind
spiegelbildlich durchzuführen.

en There are two types of installation for the shower enclosure: **a** and **b**
Situation **a** is described in this assembly instruction. The assembly steps for situation **b** must be carried out
in mirror image.

fr Il y a 2 possibilités de monter la paroi de douche : **a** et **b**
La version **a** est illustrée dans la notice de montage. Les étapes pour monter la version **b** sont inversées.

nl Er zijn twee soorten installatie voor de douchewand: **a** en **b**
Montage **a** wordt getoond in deze montagehandleiding. De montageschappen voor installatie **b** moeten in
spiegelbeeld worden uitgevoerd.

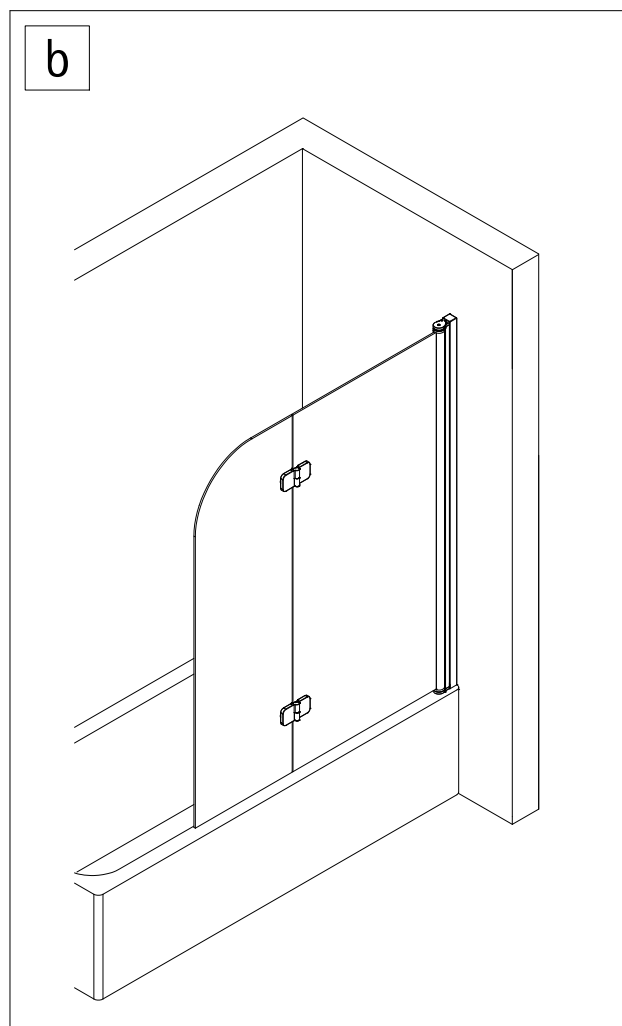
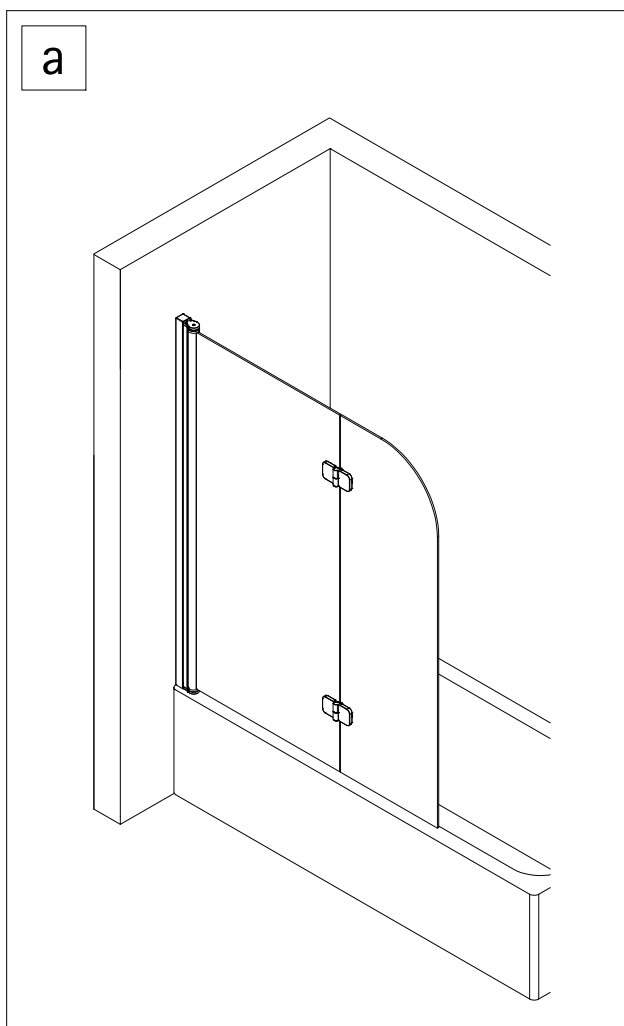

BENÖTIGTES WERKZEUG / TOOLS NEEDED
OUTILLAGE NÉCESSAIRE / BENODIGD WERKTUIG

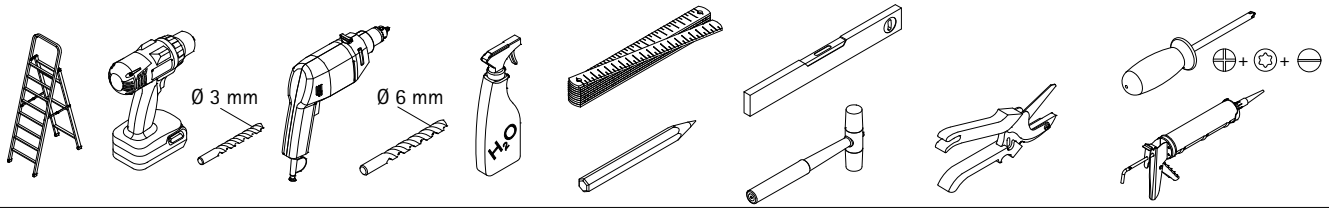

MONTAGE / ASSEMBLY / ASSEMBLAGE / ASSEMBLAGE

1

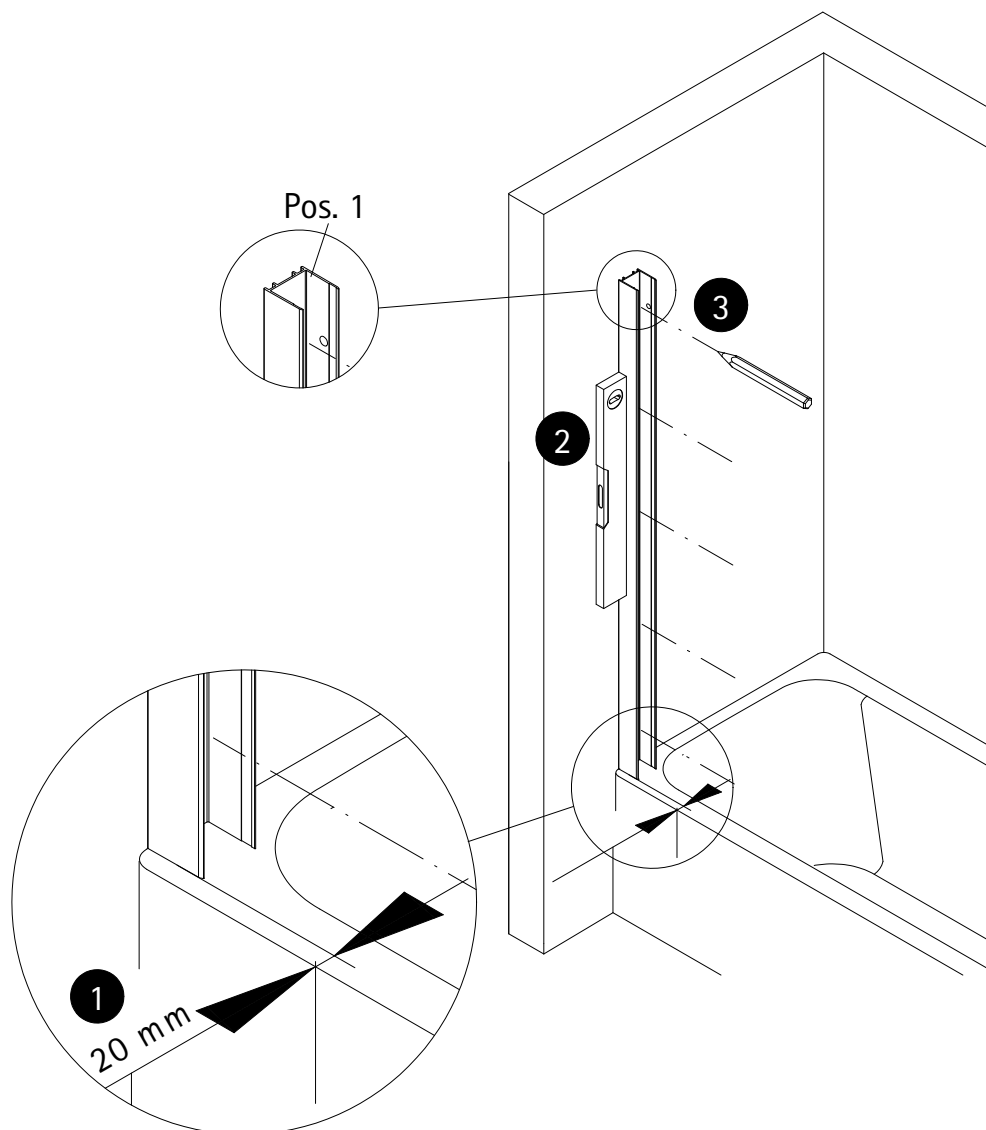

2

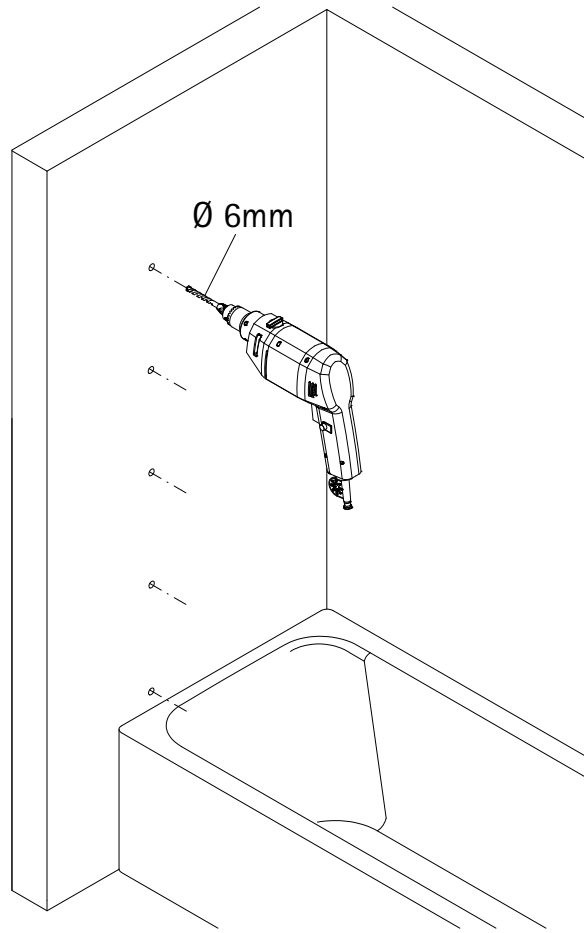
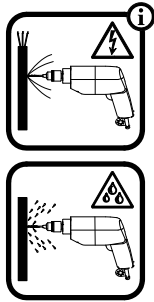

3

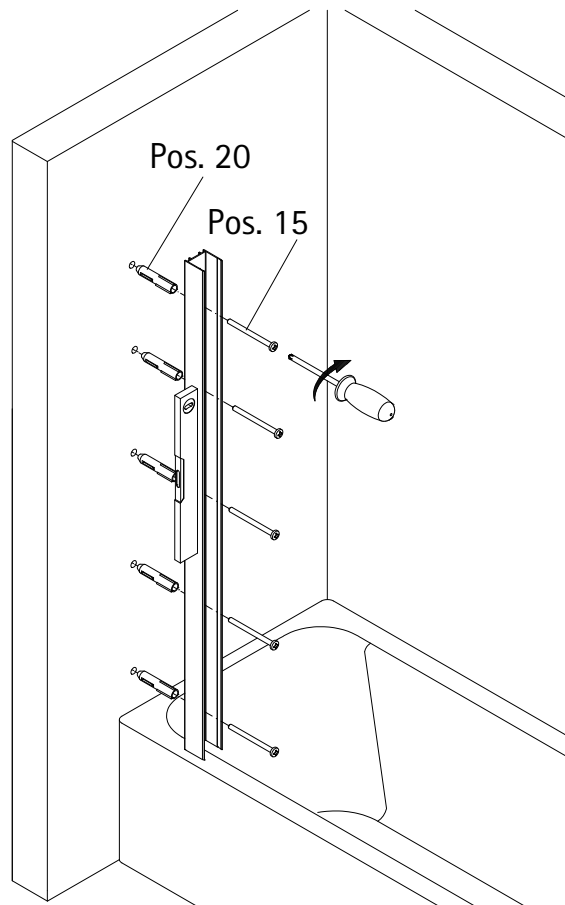

4

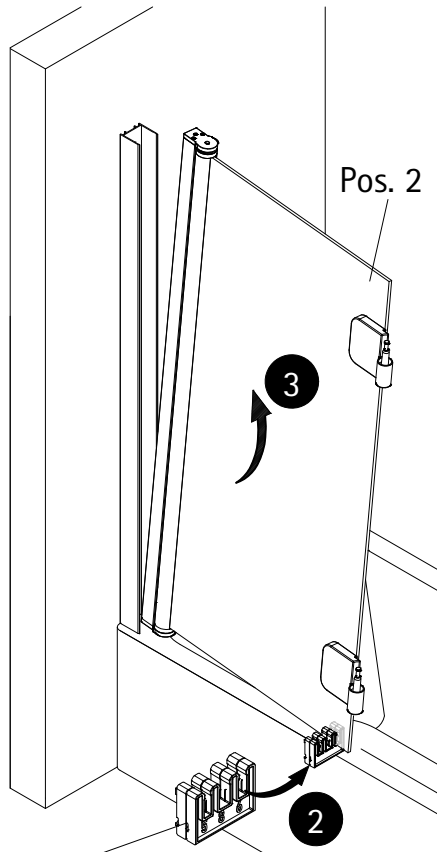
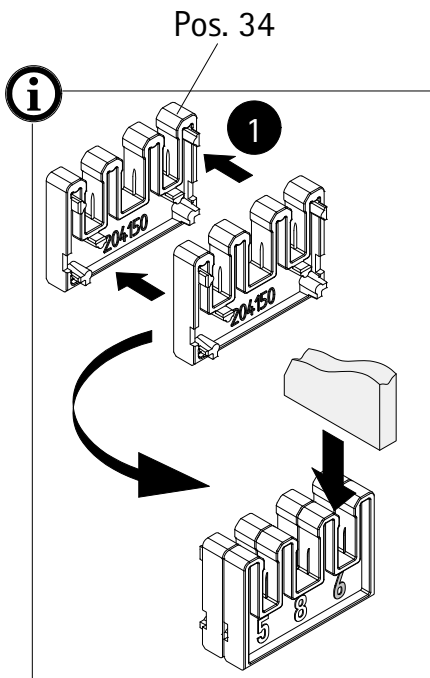

5

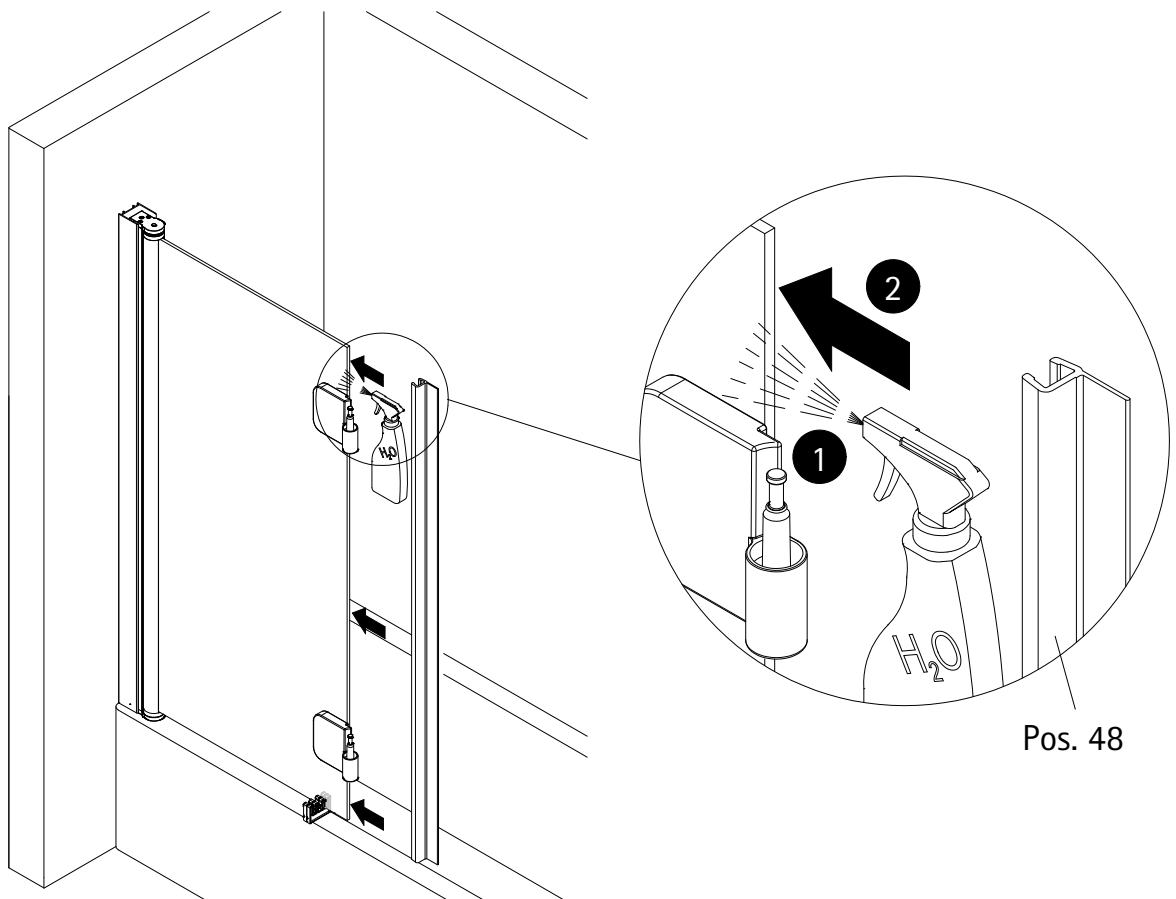

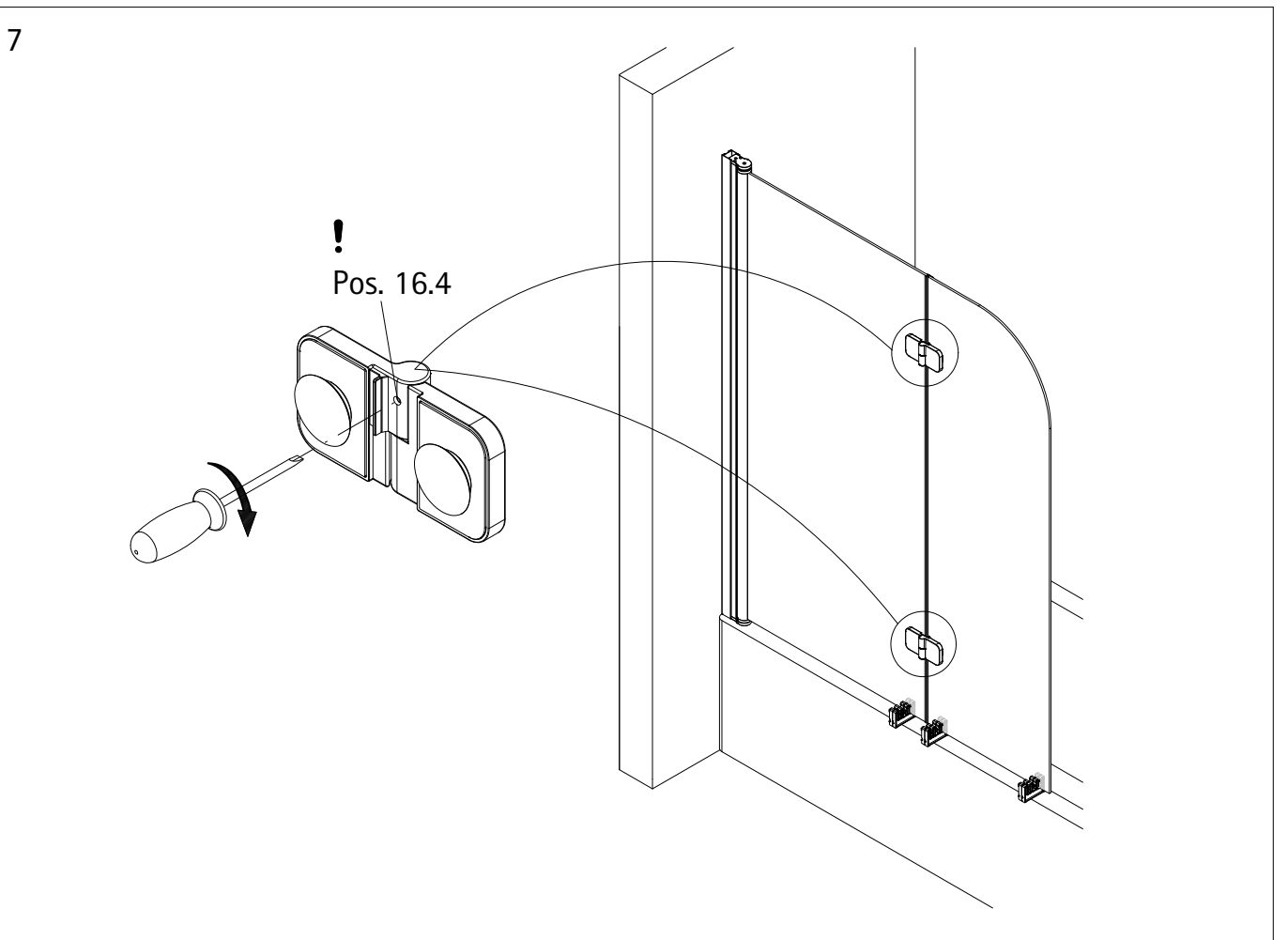
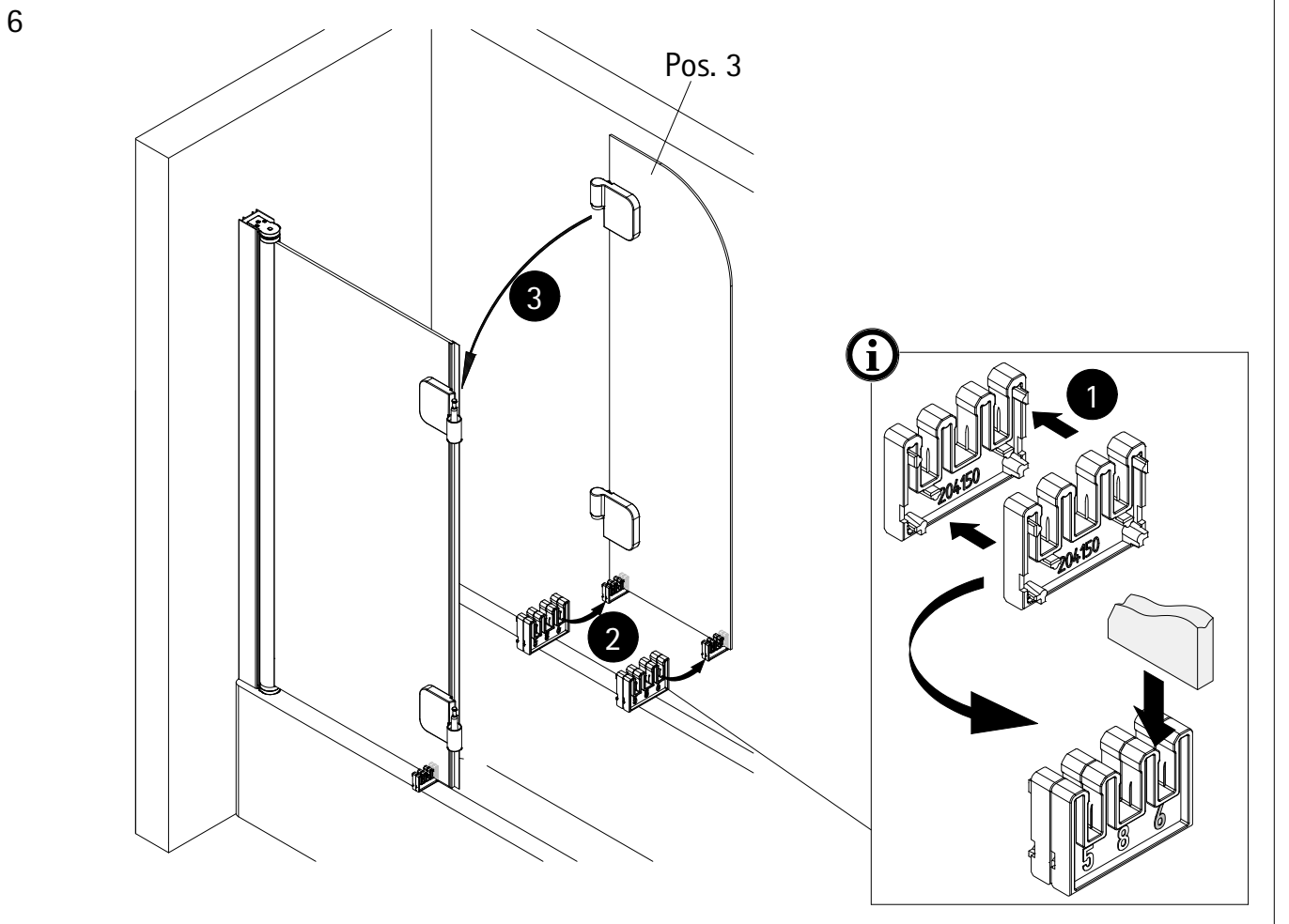

8

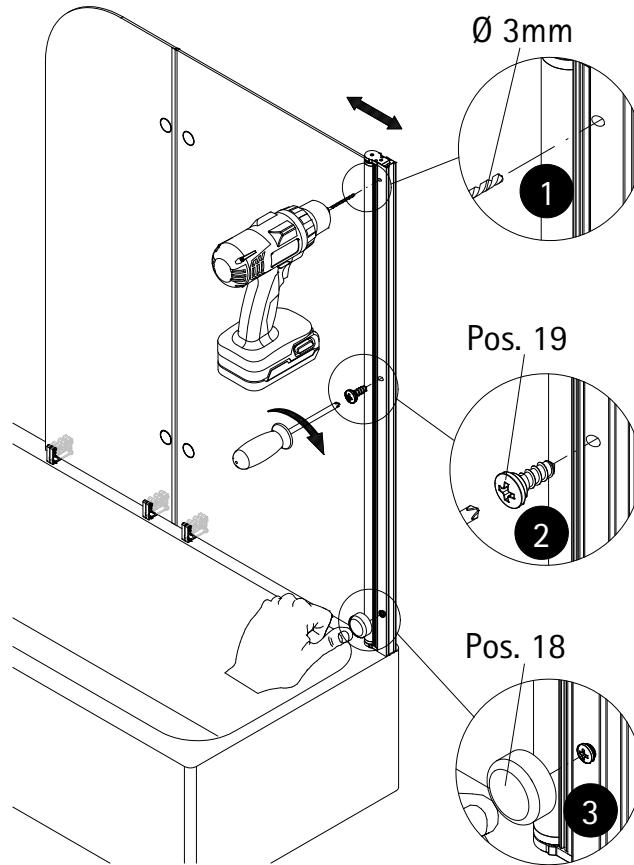

9

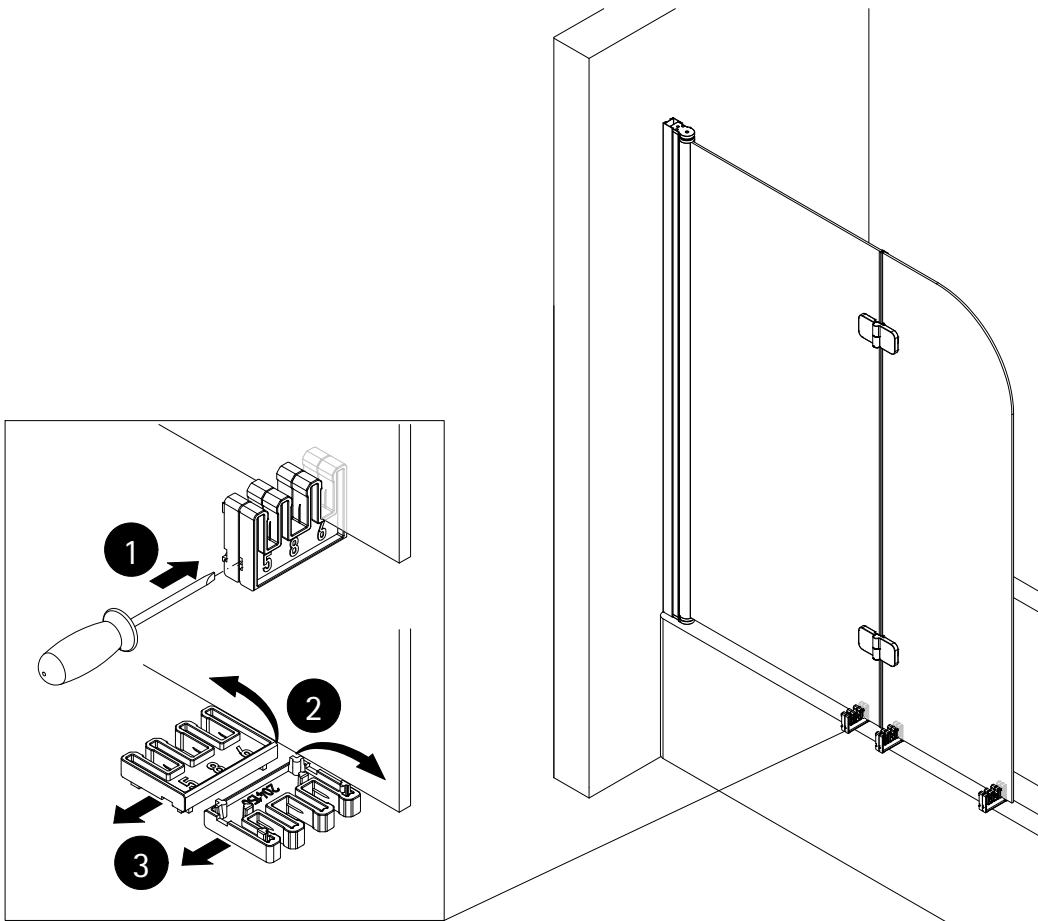

10

Pos. 21

Pos. 22

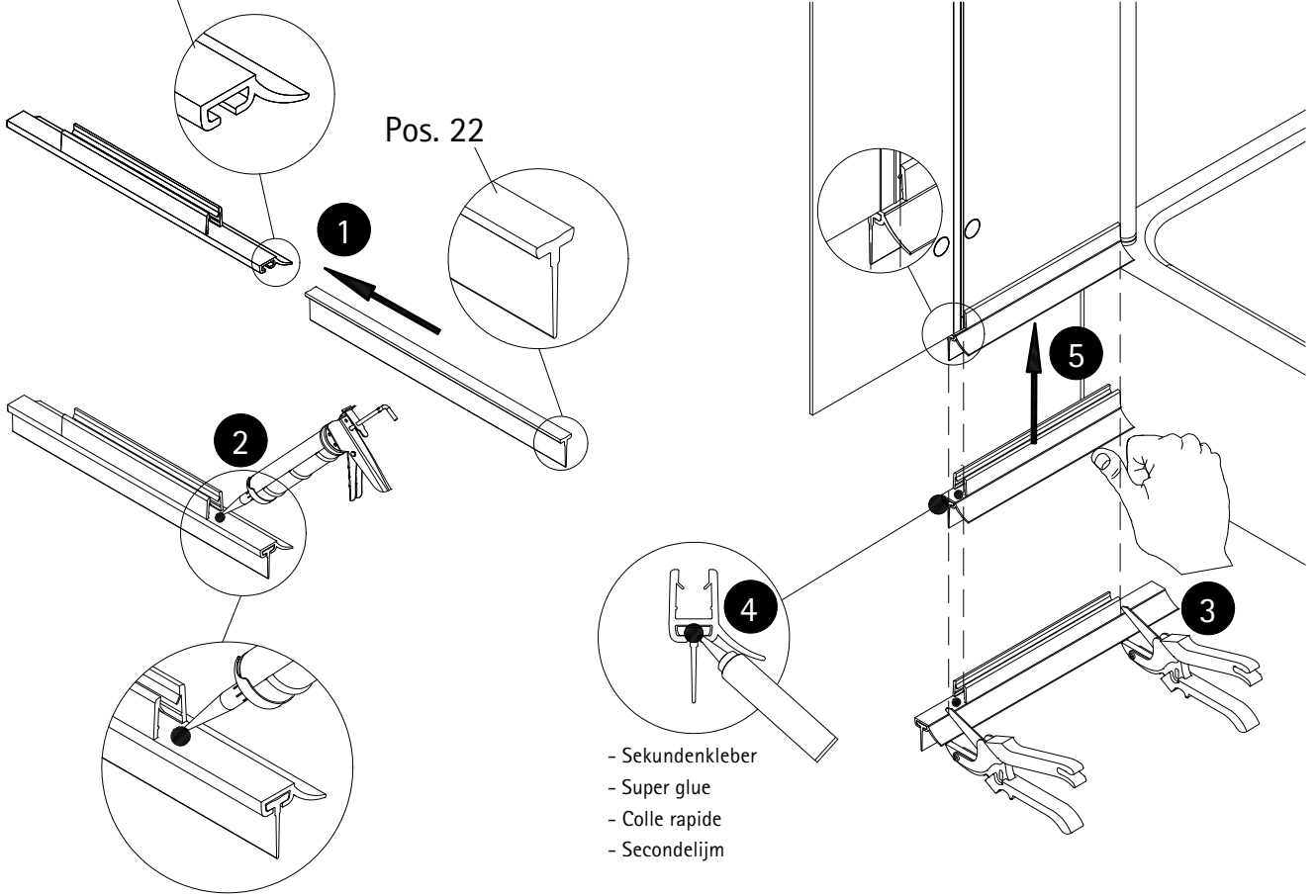

11

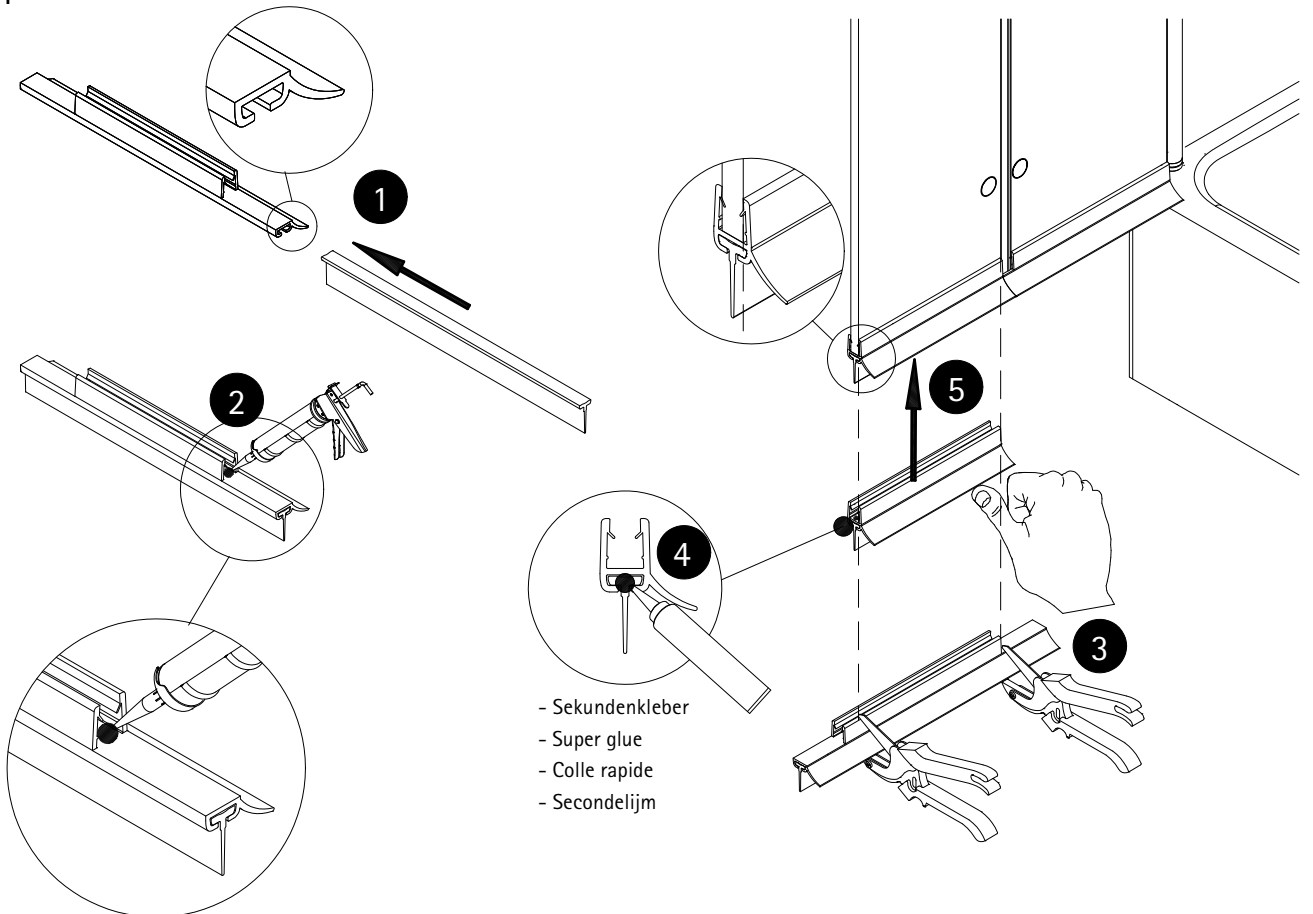

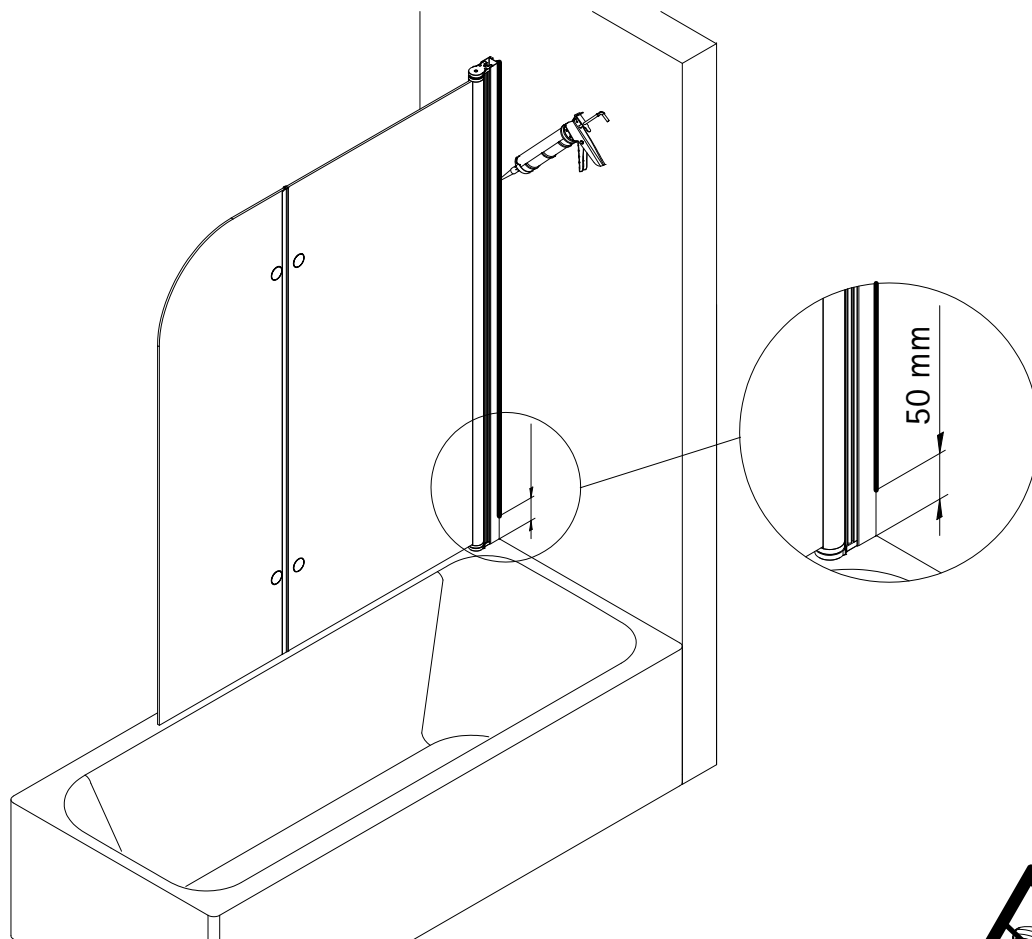

Pos. 32

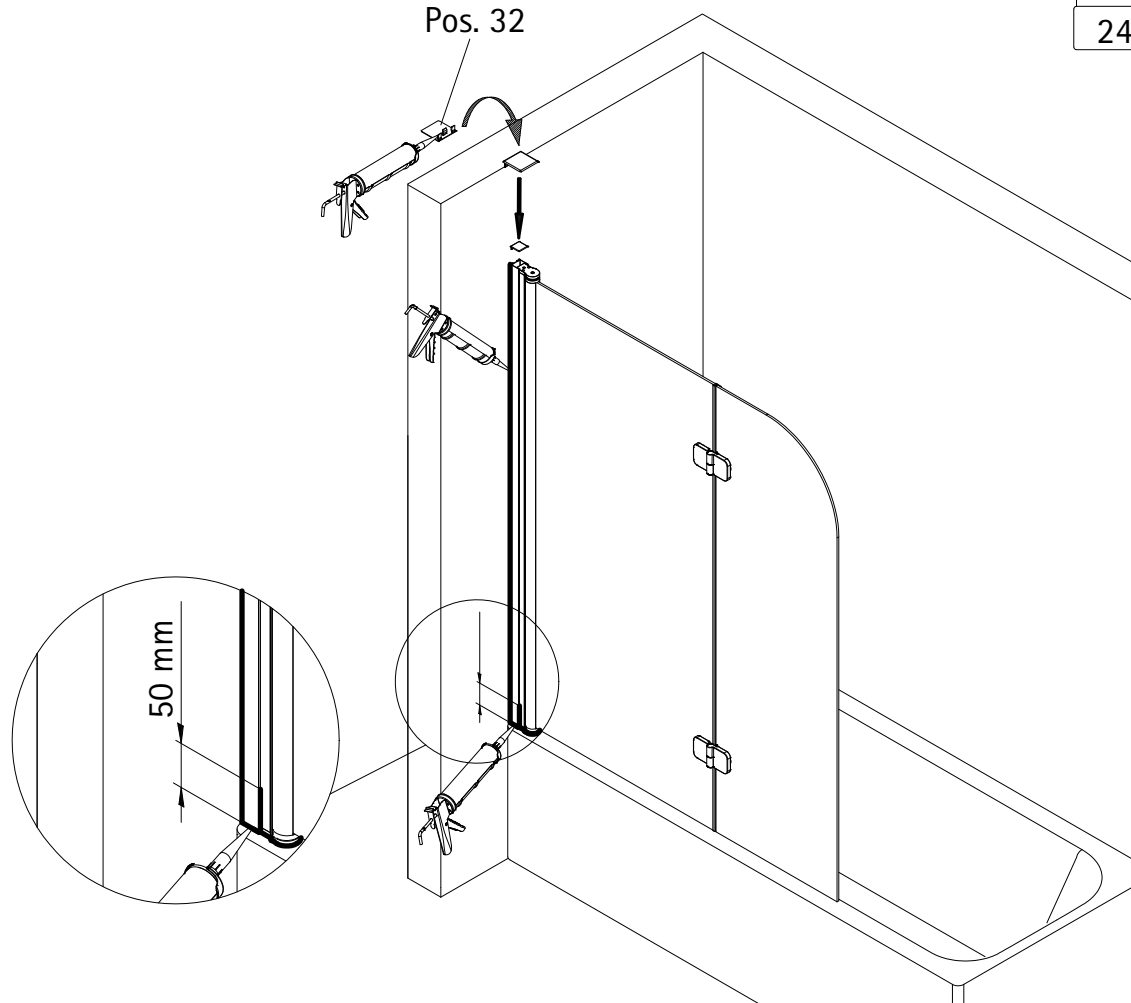

1448-6

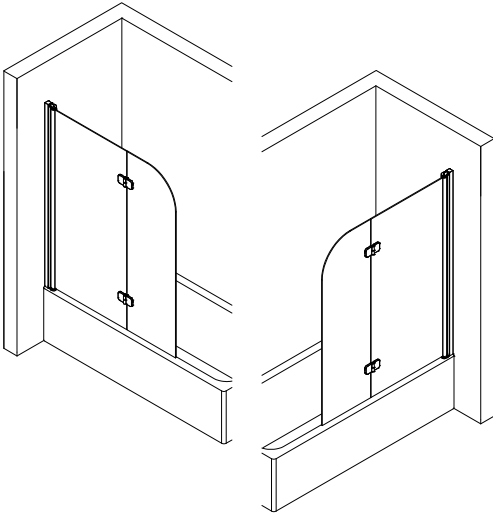

Prüfnummer / Inspection number / Numéro de contrôle / Testnummer



Ersatzteilbestellung / Spare parts order
Commande de pièces détachées / Bestelling van onderdelen:
Fax 02962 / 972-4260



Technische Hilfe / Technical help / L'aide technique / Technologische ondersteuning
Telefon 02962 / 9724-0



E-Mail:
ersatzteile@duschservice.de



Duschservice
Zum Hohlen Morgen 22
59939 Olsberg
Deutschland / Germany / Allemagne / Duitsland



0000602300000000000000000000