

<b>DE</b>	Gebrauchsanleitung / Montageanleitung	<b>2</b>
<b>FR</b>	Mode d'emploi / Instructions de montage	<b>4</b>
<b>EN</b>	Instructions for use / assembly instructions	<b>6</b>
<b>IT</b>	Istruzioni per l'uso / Istruzioni per Installazione	<b>8</b>
<b>ES</b>	Modo de empleo / Instrucciones de montaje	<b>10</b>
<b>NL</b>	Gebruiksaanwijzing / Handleiding	<b>12</b>
<b>DK</b>	Brugsanvisning / Monteringsvejledning	<b>14</b>
<b>PT</b>	Instruções para uso / Manual de Instalação	<b>16</b>
<b>PL</b>	Instrukcja obsługi / Instrukcja montażu	<b>18</b>
<b>CS</b>	Návod k použití / Montážní návod	<b>20</b>
<b>SK</b>	Návod na použitie / Montážny návod	<b>22</b>
<b>ZH</b>	用户手册 / 组装说明	<b>24</b>
<b>RU</b>	Руководство пользователя / Инструкция по монтажу	<b>26</b>
<b>HU</b>	Használati útmutató / Szerelési útmutató	<b>28</b>
<b>FI</b>	Käyttöohje / Asennusohje	<b>30</b>
<b>SV</b>	Bruksanvisning / Monteringsanvisning	<b>32</b>
<b>LT</b>	Vartotojo instrukcija / Montavimo instrukcijos	<b>34</b>
<b>HR</b>	Upute za uporabu / Uputstva za instalaciju	<b>36</b>
<b>TR</b>	Kullanım kılavuzu / Montaj kılavuzu	<b>38</b>
<b>RO</b>	Manual de utilizare / Instrucțiuni de montare	<b>40</b>
<b>EL</b>	Οδηγίες χρήσης / Οδηγία συναρμολόγησης	<b>42</b>
<b>SL</b>	Navodilo za uporabo / Navodila za montažo	<b>44</b>
<b>ET</b>	Kasutusjuhend / Paigaldusjuhend	<b>46</b>
<b>LV</b>	Lietošanas pamācība / Montāžas instrukcija	<b>48</b>
<b>SR</b>	Uputstvo za upotrebu / Uputstvo za montažu	<b>50</b>
<b>NO</b>	Bruksanvisning / Montasjeveiledning	<b>52</b>
<b>BG</b>	Инструкция за употреба / Ръководство за монтаж	<b>54</b>
<b>SQ</b>	Udhëzuesi i përdorimit / Udhëzime rreth montimit	<b>56</b>
<b>AR</b>	دليل الاستخدام / تعليمات التجميع	<b>59</b>

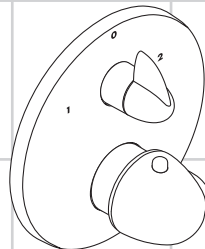

**Ecostat E**  
15720000

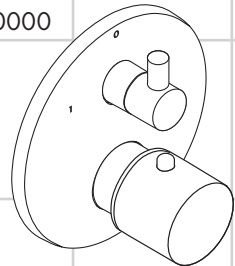

**Ecostat S**  
15721000

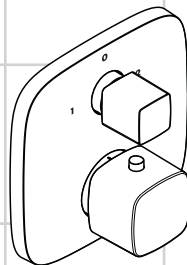

**PuraVida**  
15771XXX

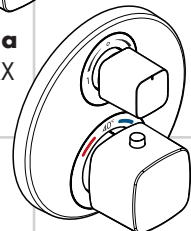

**Metris**  
31573000



## Sicherheitshinweise

- ⚠ Bei der Montage müssen zur Vermeidung von Quetsch- und Schnittverletzungen Handschuhe getragen werden.
- ⚠ Das Produkt darf nur zu Bade-, Hygiene- und Körperreinigungszwecken eingesetzt werden.
- ⚠ Kinder, sowie Erwachsene mit körperlichen, geistigen und / oder sensorischen Einschränkungen dürfen das Produkt nicht unbeaufsichtigt benutzen. Personen, die unter Alkohol- oder Drogeneinfluss stehen, dürfen das Produkt nicht benutzen.
- ⚠ Große Druckunterschiede zwischen den Kalt- und Warmwasseranschlüssen müssen ausgeglichen werden.

## Montagehinweise

- Die Armatur muss nach den gültigen Normen montiert, gespült und geprüft werden!
- Vor der Montage muss das Produkt auf Transportschäden untersucht werden. Nach dem Einbau werden keine Transport- oder Oberflächenschäden anerkannt.

## Technische Daten

Betriebsdruck:	max. 1 MPa
Empfohlener Betriebsdruck:	0,1 - 0,5 MPa
Prüfdruck:	1,6 MPa
(1 MPa = 10 bar = 147 PSI)	
Heißwassertemperatur:	max. 80 °C
Empfohlene Heißwassertemperatur:	65 °C
Thermische Desinfektion:	max. 70 °C / 4 min

Eigensicher gegen Rückfließen

Das Produkt ist ausschließlich für Trinkwasser konzipiert!

## Symbolerklärung



Kein essigsäurehaltiges Silikon verwenden!



**Bedienung** (siehe Seite 66)



**Reinigung**

siehe beiliegende Broschüre.

**max. Safety Function** (siehe Seite 62)  
≈ 42 °C

Dank der Safety Function lässt sich die gewünschte Höchsttemperatur von z. B. max. 42 °C voreinstellen.



**Einjustieren** (siehe Seite 62)

Nach erfolgter Montage muss die Auslauftemperatur des Thermostaten überprüft werden. Eine Korrektur ist erforderlich wenn die an der Entnahmestelle gemessene Temperatur von der am Thermostaten eingestellten Temperatur abweicht.



**Wartung** (siehe Seite 64)

- Um die Leichtgängigkeit der Regeleinheit zu gewährleisten, sollte der Thermostat von Zeit zu Zeit auf ganz warm und ganz kalt gestellt werden.
- Der Thermostat ist mit Rückflussverhinderern ausgestattet. Rückflussverhinderer müssen gemäß DIN EN 1717 regelmäßig in Übereinstimmung mit nationalen oder regionalen Bestimmungen auf ihre Funktion geprüft werden (mindestens einmal jährlich).



**Serviceteile** (siehe Seite 68)

XXX = Farbcodierung  
000 = chrom  
400 = weiß/chrom



**Prüfzeichen** (siehe Seite 66)



**Maße** (siehe Seite 67)



**Durchflussdiagramm**  
(siehe Seite 67)

- ① Abgang Wanne
- ② Abgang Brause

<b>Störung</b>	<b>Ursache</b>	<b>Abhilfe</b>
Wenig Wasser	- Versorgungsdruck nicht ausreichend	- Leitungsdruck prüfen
	- Schmutzfangsieb der Regeleinheit verschmutzt	- Schmutzfangsiebe vor dem Thermostat und auf der Regeleinheit reinigen
	- Siebdichtung der Brause verschmutzt	- Siebdichtung zwischen Brause und Schlauch reinigen
Kreuzfluss, warmes Wasser wird bei geschlossener Armatur in die Kaltwasserleitung gedrückt oder umgekehrt	- Rückflussverhinderer verschmutzt / defekt	- Rückflussverhinderer reinigen ggf. austauschen
Auslauftemperatur stimmt nicht mit der eingestellten Temperatur überein	- Thermostat wurde nicht justiert	- Thermostat justieren
	- Zu niedrige Warmwassertemperatur	- Warmwassertemperatur erhöhen auf 42 °C bis 65 °C
Temperaturregelung nicht möglich	- Temperaturregeleinheit verschmutzt oder verkalkt	- Temperaturregeleinheit reinigen ggf. austauschen
	- Bei Neuinstallation Grundkörper falsch angeschlossen (Soll: kalt rechts, warm links) oder 180° verdreht eingebaut	- Funktionsblock um 180° verdreht einbauen
Druckknopf der Sicherheitssperre ohne Funktion	- Feder defekt - Druckknopf verkalkt	- Feder bzw. Druckknopf reinigen u. leicht fetten, ggf. austauschen
Umsteller schwergängig	- Kartusche defekt	- Kartusche austauschen
Umsteller undicht	- Schmutz oder Ablagerungen auf dem Dichtsitz	- Dichtsitz reinigen oder Umsteller austauschen



**Montage siehe Seite 60**



## Consignes de sécurité

- ⚠ Lors du montage, porter des gants de protection pour éviter toute blessure par écrasement ou coupure.
- ⚠ Le système de douche ne doit servir qu'à se laver et à assurer l'hygiène corporelle.
- ⚠ Il est interdit aux enfants ainsi qu'aux adultes ayant des insuffisances physiques, psychiques et/ou motoriques d'utiliser la douche sans surveillance. De même, il est interdit à des personnes sous influence d'alcool ou de drogues d'utiliser la douche.
- ⚠ Il est conseillé d'équilibrer les pressions de l'eau chaude et froide.

## Instructions pour le montage

- La robinetterie doit être installée, rincée et contrôlée conformément aux normes valables!
- Avant son montage, s'assurer que le produit n'a subi aucun dommage pendant le transport. Après le montage, tout dommage de transport ou de surface ne pourra pas être reconnu.

## Informations techniques

Pression de service autorisée:	max. 1 MPa
Pression de service conseillée:	0,1 - 0,5 MPa
Pression maximum de contrôle:	1,6 MPa
(1 MPa = 10 bar = 147 PSI)	
Température d'eau chaude:	max. 80 °C
Température recommandée:	65 °C
Désinfection thermique:	max. 70 °C / 4 min

Avec dispositif anti-retour

Le produit est exclusivement conçu pour de l'eau potable!

## Description du symbole



Ne pas utiliser de silicone contenant de l'acide acétique!



## Instructions de service (voir page 66)



## Nettoyage

voir la brochure ci-jointe.

**max. Safety Function** (voir page 62)  
 ≈ 42 °C

Grâce à la fonction Safety, il est possible de prérégler la température maximale par exemple max. 42° C souhaitée.



## Réglage (voir page 62)

Le montage terminé, contrôler la température de l'eau puisée au mitigeur thermostatique. Un étalonnage est nécessaire si la température de l'eau mitigée mesurée au point de puisage diffère sensiblement de celle affichée sur le thermostat.



## Entretien (voir page 64)

- Pour assurer le mouvement facile de l'élément thermostatique, le thermostat devrait être placé de temps en temps en position très chaude et très froide.
- Le mitigeur thermostatique est équipé de clapets anti-retour. Les clapets anti-retour doivent être examinés régulièrement conformément à la norme EN 1717 ou conformément aux dispositions nationales ou régionales quant à leur fonction (au moins une fois par an).



## Pièces détachées (voir pages 68)

XXX = Couleurs  
 000 = chromé  
 400 = blanc/chromé



## Classification acoustique et débit (voir page 66)



**Dimensions** (voir page 67)



**Diagramme du débit**  
(voir page 67)

- ① Sortie baignoire
- ② Sortie douche

<b>Dysfonctionnement</b>	<b>Origine</b>	<b>Solution</b>
Pas assez d'eau	- Pression d'alimentation insuffisante	- Contrôler la pression
	- Filtre de l'élément thermostatique encrassé	- Nettoyer les filtres devant le mitigeur thermostatique et sur la cartouche
	- Joint-filtre de douchette encrassé	- Nettoyer le joint-filtre entre la douchette et le flexible
Circulation opposée, l'eau chaude est comprimée dans l'arrivée d'eau froide et vice versa avec robinet fermé	- Clapet anti-retour encrassé ou défectueux	- Nettoyer le clapet anti-retour ou le changer éventuellement
La température à la sortie ne correspond pas à la température de réglage	- Le thermostat n'a pas été réglé	- Régler le thermostat
	- Température d'eau chaude trop basse, pas d'eau froide	- Augmenter la température d'eau chaude entre 42°C et 65°C
Le réglage de la température n'est pas possible	- L'élément thermostatique est encrassé ou entartré	- Nettoyer l'élément thermostatique ou le changer éventuellement
	- La pièce de base a une alimentation inversée (l'eau froide doit être à droite et l'eau chaude à gauche) ou elle est montée à l'envers	- Montez le bloc de fonction à 180°
Bouton à pression du verrouillage de sécurité défectueux	- Ressort défectueux	- Nettoyer le ressort ou bien le bouton à pression, le changer éventuellement
	- Bouton à pression entartré	
Fonctionnement de l'inverseur difficile	- Cartouche défectueuse	- Changer la cartouche
L'inverseur n'est pas étanche	- Encrassement ou dépôt sur le siège du joint	- Nettoyez le siège ou changez éventuellement l'inverseur



**Montage voir page 60**



## Safety Notes

- △ Gloves should be worn during installation to prevent crushing and cutting injuries.
- △ The shower system may only be used for bathing, hygienic and body cleansing purposes.
- △ Children as well as adults with physical, mental and/or sensoric impairments must not use this shower system without proper supervision. Persons under the influence of alcohol or drugs are prohibited from using this shower system.
- △ The hot and cold supplies must be of equal pressures.

## Installation Instructions

- The fitting must be installed, flushed and tested after the valid norms!
- Prior to installation, inspect the product for transport damages. After it has been installed, no transport or surface damage will be honoured.

## Technical Data

Operating pressure:	max. 1 MPa
Recommended operating pressure:	0,1 - 0,5 MPa
Test pressure:	1,6 MPa
(1 MPa = 10 bar = 147 PSI)	
Hot water temperature:	max. 80°C
Recommended hot water temp.:	65°C
Thermal disinfection:	max. 70°C / 4 min

Safety against backflow

The product is exclusively designed for drinking water!

**max. Safety Function** (see page 62)  
**≈ 42° C**

The desired maximum temperature for example max. 42° C can be pre-set thanks to the safety function.



## Adjustment

 (see page 62)

After the installation, the output temperature of the thermostat must be checked. A correction is necessary if the temperature measured at the output differs from the temperature set on the thermostat.



## Maintenance

 (see page 64)

- To guarantee the smooth running of the thermostat, it is necessary from time to time to turn the thermostat from total hot to total cold.
- The mixer is equipped with check valves. The check valves must be checked regularly according to DIN EN 1717 in accordance with national or regional regulations (at least once a year).



## Spare parts

 (see page 68)

XXX = Colors  
000 = chrome plated  
400 = white/chrome plated

## Symbol description



Do not use silicone containing acetic acid!



**Operation** (see page 66)



**Cleaning**

see enclosed brochure.



**Test certificate** (see page 66)



**Dimensions** (see page 67)



**Flow diagram**

(see page 67)

- ① Tub outlet
- ② Shower outlet

<b>Fault</b>	<b>Cause</b>	<b>Remedy</b>
Insufficient water	- Supply pressure inadequate	- Check water pressure (If a pump has been installed check to see if the pump is working).
	- Regulator filter dirty	- Clean filter in front of the mixer and on the MTC-thermo cartridge
	- Shower filter seal dirty	- Clean filter seal between shower and hose
Crossflow, hot water being forced into cold water pipe, or vice versa, when mixer is closed	- Backflow preventers dirty or leaking	- Clean backflow preventers, exchange if necessary
Spout temperature does not correspond with temperature set	- Thermostat has not been adjusted	- Adjust thermostat
	- Hot water temperature too low	- Increase hot water temperature to 42 °C to 65 °C
Temperature regulation not possible	- Temperature regulator dirty or calcified	- Clean temperature regulator, exchange if necessary
	- For new installations: basic body incorrectly connected (should be: cold right, hot left) or installed with 180° rotation	- Install function block turned through 180°
Safety stop button not operating	- Spring defective	- Clean spring and/or button, exchange if necessary
	- Button calcified	
Diverter stiff	- Cartridge defective	- Exchange cartridge
Diverter leaking	- Dirt or sedimentation on valve seat.	- Clean valve seat or exchange diverter





**Special information for UK** (see page 70)



**Assembly see page 60**



## **Indicazioni sulla sicurezza**

-  Durante il montaggio, per evitare ferite da schiacciamento e da taglio bisogna indossare guanti protettivi.
-  Il sistema doccia deve essere utilizzato esclusivamente per l'igiene del corpo.
-  I bambini e gli adulti affetti da menomazioni fisiche, psichiche e/o sensoriali devono utilizzare il sistema doccia solo sotto sorveglianza. Il prodotto non deve essere utilizzato da persone sotto l'effetto di droghe o alcolici.
-  **Attenzione!** Compensare le differenze di pressione tra i collegamenti dell'acqua fredda e dell'acqua calda.

## **Istruzioni per il montaggio**

- La rubinetteria deve essere installata, pulita e testata secondo le istruzioni riportate!
- Prima del montaggio è necessario controllare che non ci siano stati danni durante il trasporto. Una volta eseguito il montaggio, non verranno riconosciuti eventuali danni di trasporto o delle superfici.

## **Dati tecnici**

Pressione d'uso:	max. 1 MPa
Pressione d'uso consigliata:	0,1 - 0,5 MPa
Pressione di prova:	1,6 MPa
(1 MPa = 10 bar = 147 PSI)	
Temperatura dell'acqua calda:	max. 80 °C
Temp. dell'acqua calda consigliata:	65 °C
Disinfezione termica:	max. 70 °C / 4 min

### Sicurezza antiriflusso

Il prodotto è concepito esclusivamente per acqua potabile!

## **Descrizione simbolo**



Non utilizzare silicone contenente acido acetico!



**Procedura** (vedi pagg. 66)



**Pulitura**

vedi il prospetto accluso.

**max. Safety Function** (vedi pagg. 62)  
 ≈ 42 °C

Grazie alla funzione antiscottature Safety la temperatura massima per esempio max. 42 °C desiderata è facilmente regolabile.



**Taratura** (vedi pagg. 62)

Effettuata l'installazione del miscelatore termostatico bisogna controllare la temperatura di uscita. La taratura è necessaria quando la temperatura dell'acqua misurata sul punto di prelievo non corrisponde a quella fissata sul termostato.



**Manutenzione** (vedi pagg. 64)

- Per garantire la scorrevolezza dell'elemento di regolazione, di tanto in tanto si dovrebbe regolare il termostatico passando da tutto caldo a tutto freddo.
- Il miscelatore termostatico è dotato di una valvola antiritorno. La valvola di non ritorno deve essere controllata regolarmente come da DIN EN 1717, secondo le normative nazionali e regionali (almeno una volta all'anno).



**Parti di ricambio** (vedi pagg. 68)

XXX = Trattamento  
 000 = cromato  
 400 = bianco/cromato



**Segno di verifica** (vedi pagg. 66)





**Ingombri** (vedi pagg. 67)



**Diagramma flusso**  
(vedi pagg. 67)

- ① uscita vasca
- ② uscita doccia

<b>Problema</b>	<b>Possibile causa</b>	<b>Rimedio</b>
Scarsità d'acqua	- Pressione di erogazione insufficiente	- Provare la pressione di erogazione
	- Filtro dell'unità di regolazione sporco	- Pulire/sostituire i filtri
	- Guarnizione del filtro della doccia sporca	- Pulire la guarnizione del filtro tra doccia e flessibile
Flusso incrociato; l'acqua calda viene spinta nella tubatura acqua fredda a rubinetteria chiusa o viceversa	- Antiriflusso sporco o non ermetico	- Pulire o sostituire l'antiriflusso
La temperatura di erogazione diversa da quella impostata	- Il termostatico non è stato regolato	- Regolare il termostatico
	- Temperatura dell'acqua calda	- Aumentare la temperatura acqua calda tra 42 °C e 65 °C
Impossibile la regolazione temperatura	- Elemento termostatico sporco o con depositi calcarei	- Pulire o sostituire l'unità di regolazione
	- In caso di nuova installazione - collegato male il termostatico (deve essere: acqua fredda a destra e calda a sinistra) o installato ruotato di 180°	- Ruotare di 180° l'unità di regolazione
Tasto antiscottatura non funzionante	- Molla difettosa - Tasto con depositi calcarei	- Pulire o sostituire la molla o il tasto
Deviatore duro	- Cartuccia difettosa	- Sostituire la cartuccia
Deviatore non ermetico	- Sporco o depositi sulla sede di tenuta	- pulire la sede della guarnizione o sostituire il deviatore



**Montaggio vedi pagg. 60**



## Indicaciones de seguridad

- △ Durante el montaje deben utilizarse guantes para evitar heridas por aplastamiento o corte.
- △ La grifería solo debe ser utilizada para fines de baño, higiene y limpieza corporal.
- △ Niños, así como adultos con limitaciones corporales, mentales y/o sensoriales no deben utilizar el sistema de duchas sin vigilancia. Personas que se encuentran bajo el efecto de alcohol o drogas, no deben utilizar el sistema de duchas.
- △ Grandes diferencias de presión en servicio entre agua fría y agua caliente deben equilibrarse.

## Indicaciones para el montaje

- El grifo tiene que ser instalado, probado y testado, según las normas en vigor.
- Antes del montaje se debe examinar el producto contra daños de transporte. Después de la instalación so se reconoce ningún daño de transporte o de superficie.

## Datos técnicos

Presión en servicio:	max. 1 MPa
Presión recomendada en servicio:	0,1 - 0,5 MPa
Presión de prueba:	1,6 MPa
(1 MPa = 10 bar = 147 PSI)	
Temperatura del agua caliente:	max. 80 °C
Temp. recomendada del agua caliente:	65 °C
Desinfección térmica:	max. 70 °C / 4 min

Seguro contra el retorno

El producto ha sido concebido exclusivamente para agua potable.

## Descripción de símbolos



No utilizar silicona que contiene ácido acético!



**Manejo** (ver página 66)



**Limpiar**

ver el folleto adjunto.

**max. Safety Function** (ver página 62)  
≈ 42 °C

Gracias al tope de temperatura se puede graduar la temperatura máxima por ejemplo max. 42 °C.



**Puesta a punto** (ver página 62)

Después del montaje deberá comprobarse la temperatura del agua del termostato, en la salida del caño. Una corrección se efectuará siempre y cuando la temperatura del agua tomada a la salida del caño, no corresponda con la indicada en el volante del termostato.



**Mantenimiento** (ver página 64)

- Para garantizar el funcionamiento duradero del termostato, el mando del mismo debería girarse de vez en cuando del extremo frío al extremo caliente.
- El termostato está equipado con válvula, la cual evita el retorno del agua a la tubería. Las válvulas anti-retorno tienen que ser controladas regularmente según la norma DIN EN 1717, en acuerdo con las regulaciones nacionales o regionales (una vez al año, por lo menos).



**Repuestos** (ver página 68)

XXX = Acabados  
000 = cromado  
400 = blanco/cromado



**Marca de verificación** (ver página 66)



**Dimensiones** (ver página 67)



**Diagrama de circulación**  
(ver página 67)

- ① Salida bañera
- ② Salida surtidor de ducha

<b>Problema</b>	<b>Causa</b>	<b>Solución</b>
Sale poca agua	- presión insuficiente	- comprobar presión
	- filtro del termoelemento sucio	- Limpiar filtros en las uniones a las tomas de agua caliente y fría y en el cartucho termostático
	- Filtro de la teleducha sucio	- Limpiar / Cambiar filtro entre flexo y teleducha
Flujo de agua cruzada agua caliente entra en la tubería del agua fría o al revés	- válvula antirretorno sucia o pierde	- limpiar / cambiar válvula
Temperatura del agua no corresponde a lo marcado	- termostato no ha sido ajustado	- ajustar termostato
	- Temperatura del agua caliente demasiado baja	- aumentar temperatura del agua caliente a 42° - 65° C.
No es posible regular la temperatura	- termoelemento sucio/lleño de cal	- limpiar / cambiar termoelemento
	- cuerpo empotrado mal montado (debe estar: frío = derecha) o instalado girado en 180°	- girar embellecedor en 180°
Botón de tope no funciona	- muelle defecto	- Limpiar y aplicar una fina capa de grasa en el muelle y el pulsador
	- botón lleño de cal	
Inversor va duro	- cartucho dañado	- cambiar el cartucho
Inversor pierde agua	- Suciedad / Sedimentaciones en el asiento de la llave	- limpiar / cambiar inversor



**Montaje ver página 60**



## Veiligheidsinstructies

- ⚠ Bij de montage moeten ter voorkoming van knel- en snijwonden handschoenen worden gedragen.
- ⚠ Het douchesysteem mag alleen voor het wassen, hygiënische doeleinden en voor de lichaamreiniging worden gebruikt.
- ⚠ Kinderen en volwassenen met lichamelijke, geestelijke en/of sensorische beperkingen mogen het douchesysteem niet zonder toezicht gebruiken. Personen onder invloed van alcohol of drugs mogen het douchesysteem niet gebruiken.
- ⚠ Grote drukverschillen tussen de koud- en warmwatertoevoer dienen vermeden te worden.

## Montage-instructies

- Leidingen doorspoelen volgens Norm. De mengkraan vervolgens monteren en controleren!
- Vóór de montage moet het product gecontroleerd worden op transportschade. Na de inbouw wordt geen transport- of oppervlakteschade meer aanvaard.

## Technische gegevens

Werkdruk: max.	max. 1 MPa
Aanbevolen werkdruk:	0,1 - 0,5 MPa
Getest bij:	1,6 MPa
(1 MPa = 10 bar = 147 PSI)	
Temperatuur warm water:	max. 80 °C
Aanbevolen warm water temp.:	65 °C
Thermische desinfectie:	max. 70 °C / 4 min

Beveiligd tegen terugstromen

Het product is uitsluitend ontworpen voor drinkwater!

## Symbolbeschrijving



Gebruik geen zuurhoudende silicone!



**Bediening** (zie blz. 66)



**Reinigen**

zie bijgevoegde brochure.

**max. Safety Function** (zie blz. 62)  
≈ 42 °C

Dankzij de Safety Function kan de gewenste maximale temperatuur van bijv. max. 42° C van te voren worden ingesteld.



**Correctie** (zie blz. 62)

Na montage dient de uitstroomtemperatuur van de thermostaat gecontroleerd te worden. Een correctie is noodzakelijk als de aan het tappunt gemeten temperatuur afwijkt van de op de thermostaat ingestelde temperatuur.



**Onderhoud** (zie blz. 64)

- Om het soepel lopen van de regeleenheid te garanderen moet de thermostaat van tijd tot tijd op heel koud en heel warm worden ingesteld.
- De thermostaat is voorzien van terugslagkleppen. Keerklappen moeten volgens DIN EN 1717 regelmatig en volgens plaatselijk geldende eisen op het functioneren gecontroleerd worden. (Tenminste een keer per jaar)



**Service onderdelen** (zie blz. 68)

XXX = Kleuren  
000 = verchromd  
400 = wit/verchromd



**Keurmerk** (zie blz. 66)



**Maten** (zie blz. 67)



**Doorstroomdiagram**  
(zie blz. 67)

- ① Uitlaat bad
- ② Uitlaat douche

<b>Storing</b>	<b>Oorzaak</b>	<b>Oplossing</b>
Weinig water	<ul style="list-style-type: none"> <li>- Druk te laag</li> <li>- Vuilzeef van thermo-element verstopt</li> <li>- Zeefdichting handdouche verstopt</li> </ul>	<ul style="list-style-type: none"> <li>- Druk controleren</li> <li>- Vuilvangzeefjes en zeefjes van regeleenheid reinigen</li> <li>- Zeefdichting handdouche reinigen</li> </ul>
Kruisstroom, warm water stroomt in gesloten toestand in koud water leiding of omgekeerd	<ul style="list-style-type: none"> <li>- Terugslagkleppen vervuild of defect</li> </ul>	<ul style="list-style-type: none"> <li>- Terugslagkleppen reinigen dan wel uitwisselen</li> </ul>
Uitstroomtemperatuur komt niet met ingestelde temperatuur overeen	<ul style="list-style-type: none"> <li>- Thermostaat niet ingesteld</li> <li>- Temperatuur van warm water te laag</li> </ul>	<ul style="list-style-type: none"> <li>- Thermostaat instellen</li> <li>- Warmwater toevoer verhogen min. 42°C naar 65°C</li> </ul>
Temperatuur niet regelbaar	<ul style="list-style-type: none"> <li>- Thermo-element vervuild of verkalkt</li> <li>- Bij nieuwe installaties: basisgarnituur verkeerd aangesloten (moet zijn koud rechts en warm links) of 180° gedraaid gemonteerd</li> </ul>	<ul style="list-style-type: none"> <li>- Thermo-element reinigen dan wel uitwisselen</li> <li>- Functieblok 180° draaien</li> </ul>
Safety Stop knop op thermostaatgreep functioneert niet	<ul style="list-style-type: none"> <li>- Veer defect</li> <li>- Drukknop verkalkt</li> </ul>	<ul style="list-style-type: none"> <li>- Veer en/of drukknoop reinigen dan wel uitwisselen</li> </ul>
Omstelling gaat zwaar	<ul style="list-style-type: none"> <li>- Kardoes defect</li> </ul>	<ul style="list-style-type: none"> <li>- Kardoes uitwisselen</li> </ul>
Omstelling lekt	<ul style="list-style-type: none"> <li>- Vuil of afzettingen op de zitting</li> </ul>	<ul style="list-style-type: none"> <li>- Zittingen reinigen of omstelling uitwisselen</li> </ul>



**Montage zie blz. 60**



## Sikkerhedsanvisninger

- △ Ved monteringen skal der bruges handsker for at undgå kvæstelser og snitsår.
- △ Brusersystemet må kun bruges til bade-, hygiejne og rengøringsformål.
- △ Børn som også voksne med fysiske, mentale og / eller sensoriske begrænsninger må ikke bruge brusersystemet uden opsyn. Personer som er under indflydelse af alkohol eller narkotika må ikke bruge brusersystemet.
- △ Større trykforskelle mellem koldt og varmt vand bør udjævnes.

## Monteringsanvisninger

- Ifølge gældende regler, skal armaturet monteres, skylles igennem og afprøves.
- Før monteringen skal produktet kontrolleres for transportskader. Efter monteringen godkendes transportskader eller skader på overfladen ikke længere.

## Tekniske data

Driftstryk:	max. 1 MPa
Anbefalet driftstryk:	0,1 - 0,5 MPa
Prøvetryk:	1,6 MPa
(1 MPa = 10 bar = 147 PSI)	
Varmtvandstemperatur:	max. 80 °C
Anbefalet varmtvandsstemperatur:	65 °C
Termisk desinfektion:	max. 70 °C / 4 min

Med indbygget kontraventil

Produktet er udelukkende beregnet til drikkevand!

## Symbolbeskrivelse



Der må ikke benyttes eddikesyreholdig silikone!



**Brugsanvisning** (se s. 66)



**Rengøring**

se venligst den vedlagte brochure.

**max. Safety Function** (se s. 62)  
≈ 42 °C

Takket være Safety varmtvandsbegrænsningen kan maksimaltemperaturen forudindstilles eksempel max. 42 °C.



**Justering** (zie blz. 62)

Efter monteringen skal termostatsens udløbstemperatur kontrolleres. Såfremt den målte vandtemperatur afviger fra den på termostaten viste forindstilling er en korrigerende af skalagrebet nødvendig.



**Service** (se s. 64)

- For at sikre optimal funktion af termostaten, bør termostaten fra tid til anden motioneres (stilles skiftevis helt varm og helt kold).
- Termostaten er forsynet med kontraventil . Ifølge DIN EN 1717 skal gennemstrømningsbegrænsere i overensstemmelse med nationale regler afprøves regelmæssigt (mindst en gang om året).



**Reserve dele** (se s. 68)

XXX = Overflade  
000 = Krom  
400 = Hvid/Krom



**Godkendelse** (se s. 66)



## Målene (se s. 67)



## Gennemstrømningsdiagram

(se s. 67)

- ① Afløb kar
- ② Afløb bruser

Fejl	Årsag	Hjælp
For lidt vand	<ul style="list-style-type: none"> <li>- Forsyningstrykket er ikke højt nok</li> <li>- Smudsfangsien er snavset</li> </ul>	<ul style="list-style-type: none"> <li>- Afprøv forsyningstrykket</li> <li>- Rengør smudsfangsi foran termsotaten og på termostatelementet</li> </ul>
Kryds-flow, varmt vand i koldvandsledningen og omvendt	<ul style="list-style-type: none"> <li>- Sien mellem bruser og slange er snavset</li> </ul>	<ul style="list-style-type: none"> <li>- Rengør sien mellem bruser og slange</li> </ul>
Udløbstemperaturen stemmer ikke overens med den indstillede temperatur	<ul style="list-style-type: none"> <li>- Kontraventilen er snavset eller utæt.</li> </ul>	<ul style="list-style-type: none"> <li>- Rengør kontraventilen eller udskift den evt.</li> </ul>
Temperaturregulering ikke mulig	<ul style="list-style-type: none"> <li>- Termostaten er ikke justeret</li> <li>- For lav varmtvands-temperatur</li> </ul>	<ul style="list-style-type: none"> <li>- Juster termostaten!</li> <li>- Forhøj varmtvands-temperaturen fra 42°C til 65°C</li> </ul>
Sikkerhedsspærren er ude af funktion	<ul style="list-style-type: none"> <li>- Termostatelementet er snavset eller tilkalket</li> <li>- Ved ny-installation er vandtilslutningen forbyttet (skal være koldt til højre - varmt til venstre eller også er grundkroppen drejet 180°)</li> </ul>	<ul style="list-style-type: none"> <li>- Rengør termostat-elementet eller udskift det evt.</li> <li>- Vend indbygningsdelen 180°</li> </ul>
Omstiller går trægt	<ul style="list-style-type: none"> <li>- Defekt fjeder</li> <li>- Trykknappen tilkalket</li> </ul>	<ul style="list-style-type: none"> <li>- Rengør fjeder og trykknop eller udskift delene</li> </ul>
Omstiller går utæt	<ul style="list-style-type: none"> <li>- Defekt kartusche</li> </ul>	<ul style="list-style-type: none"> <li>- Udskift kartusche</li> </ul>
Omstiller utæt	<ul style="list-style-type: none"> <li>- Smuds eller aflejringer på tætningen</li> </ul>	<ul style="list-style-type: none"> <li>- Rengør pakning eller udskift omstiller</li> </ul>





## Avisos de segurança

- ⚠ Durante a montagem devem ser utilizadas luvas de protecção, de modo a evitar ferimentos resultantes de entalamentos e de cortes.
- ⚠ O sistema de duche só pode ser utilizado para fins de higiene pessoal.
- ⚠ Crianças e adultos com deficiências motoras, mentais e/ou sensoriais não podem utilizar o sistema de duche sem monitorização. Pessoas que estejam sob a influência de álcool ou drogas não podem utilizar o sistema de duche.
- ⚠ Grandes diferenças entre as pressões das águas quente e fria devem ser compensadas.

## Avisos de montagem

- A misturadora deve ser instalada, purgada e testada de acordo com as normas em vigor!
- Antes da montagem deve-se controlar o produto relativamente a danos de transporte. Após a montagem não são aceites quaisquer danos de transporte ou de superfície.

## Dados Técnicos

Pressão de funcionamento:	max. 1 MPa
Pressão de func. recomendada:	0,1 - 0,5 MPa
Pressão testada:	1,6 MPa
(1 MPa = 10 bar = 147 PSI)	
Temperatura da água quente:	max. 80 °C
Temp. água quente recomendada:	65 °C
Desinfecção térmica:	max. 70 °C / 4 min

Função anti-retorno e anti-vácuo

Este produto foi única e exclusivamente concebido para água potável!

## Descrição do símbolo



Não utilizar silicone que contenha ácido acético!



**Funcionamento** (ver página 66)



**Limpeza**

consultar a seguinte brochura.

**max. Safety Function** (ver página 62)  
**≈ 42 °C**

Graças à função de segurança pode-se regular a temperatura máxima por exemplo max. 42°C.



**Afinação** (ver página 62)

É necessária correcção se a temperatura medida no ponto de saída diferir da temperatura marcada na escala.



**Manutenção** (ver página 64)

- Para garantir um funcionamento suave do elemento termostático é necessário de vez em quando rodar totalmente o manípulo da termostática da posição quente para a fria.
- A misturadora está equipada com válvulas anti-retorno. As válvulas anti-retorno devem ser verificadas regularmente de acordo com a DIN EN 1717 segundo os regulamentos nacionais ou regionais (pelo menos uma vez por ano).



**Peças de substituição** (ver página 68)

XXX = Acabamentos

000 = cromado

400 = branco/cromado



**Marca de controlo** (ver página 66)





**Medidas** (ver página 67)



**Fluxograma**  
(ver página 67)

- ① Saída da banheira
- ② Saída do chuveiro

<b>Falha</b>	<b>Causa</b>	<b>Solução</b>
Água insuficiente	<ul style="list-style-type: none"> <li>- Pressão não adequada</li> <li>- Filtro do regulador sujo</li> <li>- Filtro do vedante do chuveiro sujo</li> </ul>	<ul style="list-style-type: none"> <li>- Verificar a pressão da água</li> <li>- Limpar o filtro entre o chuveiro e o tubo flexível</li> <li>- Limpar o filtro entre o chuveiro e o tubo flexível</li> </ul>
Fluxos cruzados, água quente a ser forçada a entrar no tubo da água fria, ou vice-versa, quando a misturadora está fechada.	<ul style="list-style-type: none"> <li>- Válvula anti-retorno suja ou com fugas</li> </ul>	<ul style="list-style-type: none"> <li>- Limpar a válvula antiretorno, substitua se necessário</li> </ul>
A temperatura da água não corresponde à temperatura seleccionada	<ul style="list-style-type: none"> <li>- A misturadora termos táctica não foi ajustada</li> <li>- Temperatura da água quente muito baixa</li> </ul>	<ul style="list-style-type: none"> <li>- Ajustar a misturadora termostática</li> <li>- Aumentar a temperatura da água quente para 42° C a 65° C.</li> </ul>
Não é possível regular a temperatura	<ul style="list-style-type: none"> <li>- Regulador da temperatura sujo ou calcificado</li> <li>- Para novas instalações: Corpo instalado incorrectamente (deve ser: fria direita, quente esquerda) ou instalado com uma rotação de 180°</li> </ul>	<ul style="list-style-type: none"> <li>- Limpar o regulador de temperatura, substitua se necessário</li> <li>- Instalar o corpo virado 180°</li> </ul>
Botão de segurança não funciona	<ul style="list-style-type: none"> <li>- Mola defeituosa</li> <li>- Botão calcificado</li> </ul>	<ul style="list-style-type: none"> <li>- Limpar a mola e/ou o botão, substitua se necessário</li> </ul>
Inversor perro	<ul style="list-style-type: none"> <li>- Cartucho defeituoso</li> </ul>	<ul style="list-style-type: none"> <li>- Substituir o cartucho</li> </ul>
Inversor a pingar	<ul style="list-style-type: none"> <li>- Sujidade ou depósitos no assento da válvula</li> </ul>	<ul style="list-style-type: none"> <li>- Limpar o assento da válvula ou substituir o inversor</li> </ul>



**Montagem ver página 60**



## Wskazówki bezpieczeństwa

- △ Aby uniknąć zranień, takich jak zgniecenia czy przecięcia, podczas montażu należy nosić rękawice.
- △ Pysznica może być używany tylko do kąpieli, higieny i czyszczenia ciała.
- △ Zarówno dzieci, jak i dorośli z fizycznymi, psychicznymi i/lub sensorycznymi ograniczeniami nie mogą korzystać z prysznica bez opieki. Osoby znajdujące się pod wpływem alkoholu lub narkotyków nie mogą korzystać z prysznica.
- △ Znaczne różnice ciśnień na dopływach ciepłej i zimnej wody muszą zostać wyrównane.

## Wskazówki montażowe

- Armatura musi być zamontowana, przepłukana i wypróbowana według obowiązujących norm!
- Przed montażem należy skontrolować produkt pod kątem szkód transportowych. Po montażu nie widać żadnych szkód transportowych ani szkód na powierzchni.

## Dane techniczne

Ciśnienie robocze:	maks. 1 MPa
Zalecane ciśnienie robocze:	0,1 - 0,5 MPa
Ciśnienie próbne:	1,6 MPa
(1 MPa = 10 bary = 147 PSI)	
Temperatura wody gorącej:	maks. 80 °C
Zalecana temperatura wody gorącej:	65 °C
Dezynfekcja termiczna:	maks. 70 °C / 4 min

Samoistnie zabezpieczony przed przepływem zwrotnym  
Produkt stworzono wyłącznie do wody pitnej!

## Opis symbolu



Nie stosować silikonów zawierających kwas octowy!



**Obsługa** (patrz strona 66)



**Czyszczenie**

patrz dołączona broszura.

**max. Safety Function** (patrz strona 62)  
≈ 42 °C

Dzięki funkcji zabezpieczającej można przestawić żądaną maksymalną temperaturę np. na maks. 42°C.



**Regulacja** (patrz strona 62)

Po ukończeniu montażu należy sprawdzić temperaturę ciepłej wody na wylocie z termostatu. Korekta będzie konieczna wtedy, gdy zmierzona temperatura na wylocie różni się od temperatury nastawionej na termostacie.



**Konserwacja** (patrz strona 64)

- Aby zachować łatwość obsługi termostatu, od czasu do czasu należy go przekręcić na całkiem zimną i na całkiem ciepłą wodę.
- Termostat wyposażony został w zabezpieczenia przed przepływem zwrotnym. Zgodnie z normą DIN EN 1717, krajowymi i miejscowymi przepisami, działanie zabezpieczeń przed przepływem zwrotnym musi być kontrolowane (przynajmniej raz w roku).



**Części serwisowe** (patrz strona 68)

XXX = kody wykończenia powierzchni  
000 = chrom  
400 = biały/chrom



**Znak jakości** (patrz strona 66)



**Wymiary** (patrz strona 67)



**Schemat przepływu**  
(patrz strona 67)

- ① Odpływ wanny
- ② Odpływ prysznicza





<b>Usterka</b>	<b>Przyczyna</b>	<b>Pomoc</b>
Mała ilość wody	<ul style="list-style-type: none"> <li>- Zbyt niskie ciśnienie zasilające</li> <li>- Zabrudzone sitko przy wkładzie termostatycznym</li> <li>- Zabrudzona uszczelka z sitkiem w prysznicu</li> </ul>	<ul style="list-style-type: none"> <li>- Sprawdzić ciśnienie w instalacji</li> <li>- Wyczyścić sitka przed termostatem i we wkładzie termostatycznym</li> <li>- Oczyszczyć uszczelkę z sitkiem pomiędzy prysznicem a wężem</li> </ul>
Przepływ krzyżowy, woda ciepła przy zamkniętej armaturze wpływa do przewodu wody zimnej lub odwrotnie	<ul style="list-style-type: none"> <li>- Zabrudzone / uszkodzone zabezpieczenie przed przepływem zwrotnym</li> </ul>	<ul style="list-style-type: none"> <li>- Wyczyścić wzgl. wymienić zabezpieczenie przed przepływem zwrotnym</li> </ul>
Temperatura wody nie zgadza się z ustawioną wartością	<ul style="list-style-type: none"> <li>- Termostat nie został wyregulowany</li> <li>- Za niska temperatura ciepłej wody</li> </ul>	<ul style="list-style-type: none"> <li>- Przeprowadzić regulację termostatu</li> <li>- Podwyższyć temperaturę wody ciepłej na 42°C do 65°C</li> </ul>
Brak możliwości regulacji temperatury	<ul style="list-style-type: none"> <li>- Zabrudzony lub zakamieniony termostat</li> <li>- Przy nowej instalacji niewłaściwie podłączony korpus (powinno być: zimna po prawej, ciepła po lewej) albo zamontowano z przekręceniem o 180°.</li> </ul>	<ul style="list-style-type: none"> <li>- Wyczyścić lub wymienić termostat</li> <li>- Blok funkcyjny obrócić o 180°</li> </ul>
Złe funkcjonowanie przycisku zabezpieczającego	<ul style="list-style-type: none"> <li>- Uszkodzona sprężynka</li> <li>- przycisk zakamieniony</li> </ul>	<ul style="list-style-type: none"> <li>- Wyczyścić wzgl. wymienić sprężynkę lub przycisk i lekko nasmarować</li> </ul>
Przetącznik pracuje z wysiłkiem	<ul style="list-style-type: none"> <li>- Uszkodzony wkład</li> </ul>	<ul style="list-style-type: none"> <li>- Wymiana wkładu</li> </ul>
Nieszczelny przetącznik	<ul style="list-style-type: none"> <li>- Brud lub osady na gnieździe uszczelniającym</li> </ul>	<ul style="list-style-type: none"> <li>- Wyczyścić miejsce uszczelnienia lub wymienić przetącznik</li> </ul>



**Montaż patrz strona 60**



## **Bezpečnostní pokyny**

-  Pro zabránění řezným zraněním a pohmožděninám je nutné při montáži nosit rukavice.
-  Produkt smí být používán pouze ke koupání a za účelem tělesné hygieny.
-  Děti a dospělé osoby s tělesným, duševním a / nebo smyslovým postižením nesmí produkt používat bez dozoru. Osoby pod vlivem alkoholu nebo drog nesmí produkt používat.
-  Je nutné vyrovnat velké rozdíly tlaku mezi přípoji studené a teplé vody.

## **Pokyny k montáži**

- Armatura se musí montovat, proplachovat a testovat podle platných norem!
- Před montáží je třeba produkt zkontrolovat, zda nebyl při transportu poškozen. Po zabudování nebudou uznány žádné škody způsobené transportem nebo poškození povrchu.

## **Technické údaje**

Provozní tlak:	max. 1 MPa
Doporučený provozní tlak:	0,1 - 0,5 MPa
Zkušební tlak:	1,6 MPa
(1 MPa = 10 bar = 147 PSI)	
Teplota horké vody:	max. 80 °C
Doporučená teplota horké vody:	65 °C
Teplná desinfekce:	max. 70 °C / 4 min

Vlastní jistiění proti zpětnému nasátí.

Výrobky Hansgrohe jsou vhodné pro přímý kontakt s pitnou vodou.

## **Popis symbolů**



Nepoužívat silikon s obsahem kyseliny octové!



**Ovládání** (viz strana 66)



**Čištění**

viz přiložená brožura.

**max. Safety Function** (viz strana 62)  
≈ 42 °C

Díky Safety Function je možné předem nastavit nejvyšší požadovanou teplotu, např. max. 42 °C.



**Nastavení** (viz strana 62)

Po ukončení montáže se musí zkontrolovat teplota vody vytékající z termostatu. Pokud se teplota změněná v místě odběru liší od teploty nastavené na termostatu, je nutné provést korekci.



**Údržba** (viz strana 64)

- Aby byl zajištěn lehký chod regulační jednotky, měl by se termostat čas od času nastavit na úplně horkou a úplně studenou vodu.
- Termostat je vybaven omezovačem zpětného toku. U zpětných ventilů se musí podle DIN EN 1717 v souladu s národními nebo regionálními předpisy testovat jejich funkčnost (alespoň jednou ročně).



**Servisní díly** (viz strana 68)

XXX = kód povrchové úpravy  
000 = chrom  
400 = bílá/chrom



**Zkušební značka** (viz strana 66)



**Rozměry** (viz strana 67)



**Diagram průtoku**

(viz strana 67)

- ① Odtok vany
- ② Odtok sprchy

<b>Porucha</b>	<b>Příčina</b>	<b>Odstranění</b>
Málo vody	<ul style="list-style-type: none"> <li>- Nízký tlak v přívodu.</li> <li>- Zanesený lapač nečistot v regulační jednotce</li> <li>- Sítko v těsnění u sprchy zanesené</li> </ul>	<ul style="list-style-type: none"> <li>- Zkontrolovat tlak v potrubí</li> <li>- Vyčistit lapače nečistot před termostatem a na regulační jednotce</li> <li>- Vyčistit sítko v těsnění mezi sprchou a hadicí</li> </ul>
Křížení toků, teplá voda se při zavřené armatuře tlačí do přívodu studené vody nebo naopak	<ul style="list-style-type: none"> <li>- Znečištěný nebo netěsný zpětný ventil</li> </ul>	<ul style="list-style-type: none"> <li>- Zpětný ventil vyčistit, případně vyměnit</li> </ul>
Teplota u výstupu nesouhlasí s nastavenou teplotou	<ul style="list-style-type: none"> <li>- Teplota u výstupu nesouhlasí s nastavenou teplotou</li> <li>- Nízká teplota teplé vody</li> </ul>	<ul style="list-style-type: none"> <li>- Nastavit termostat</li> <li>- Teplotu horké vody zvýšit na 42°C až 65°C</li> </ul>
Nelze regulovat teplotu	<ul style="list-style-type: none"> <li>- Regulační jednotka teploty znečištěná nebo zanesená vodním kamenem</li> <li>- U nové instalace: obráceně připojené základní těleso (má být studená vpravo, teplá vlevo) nebo zabudované otočené o 180°</li> </ul>	<ul style="list-style-type: none"> <li>- Regulační jednotku teploty vyčistit, případně vyměnit</li> <li>- Funkční blok zabudovat otočený o 180°</li> </ul>
Tlačítko bezpečnostní pojistky je nefunkční	<ul style="list-style-type: none"> <li>- Vadná pružina</li> <li>- Tlačítko zanesené vodním kamenem</li> </ul>	<ul style="list-style-type: none"> <li>- Pružinu nebo tlačítko očistit a lehce potřít tukem, případně vyměnit</li> </ul>
Netěsný přepínač	<ul style="list-style-type: none"> <li>- Kartuše je vadná</li> </ul>	<ul style="list-style-type: none"> <li>- Kartuši vyměnit</li> </ul>
Netěsný přepínač	<ul style="list-style-type: none"> <li>- nečistoty nebo usazeniny na těsnicím sedle</li> </ul>	<ul style="list-style-type: none"> <li>- Očistit těsnicí sedlo nebo vyměnit přepínač</li> </ul>





## **Bezpečnostné pokyny**

- △ Pri montáži musíte nosiť rukavice, aby ste predišli pomliaždeninám a rezným poraneniam.
- △ Produkt sa smie používať len na kúpanie a telesnú hygienu.
- △ Produkt nesmú bez dozoru používať deti, ako aj dospelé osoby s telesným, duševným a/alebo zmyslovým postihnutím. Produkt nesmú používať ani osoby, ktoré sú pod vplyvom alkoholu alebo drog.
- △ Veľké rozdiely v tlaku medzi prípojkami studenej a teplej vody musia byť vyrovnané.

## **Pokyny pre montáž**

- Batéria sa musí montovať, preplachovať a testovať podľa platných noriem!
- Pred montážou musíte produkt skontrolovať, či nebol počas transportu poškodený. Po zabudovaní nebudú uznané žiadne škody spôsobené transportom alebo poškodenia povrchu.

## **Technické údaje**

Prevádzkový tlak:	max. 1 MPa
Doporučený prevádzkový tlak:	0,1 - 0,5 MPa
Skúšobný tlak:	1,6 MPa
(1 MPa = 10 bar = 147 PSI)	
Teplota teplej vody:	max. 80 °C
Doporučená teplota teplej vody:	65 °C
Termická dezinfekcia:	max. 70 °C / 4 min

Vlastná poisťka proti spätnému nasatiu.

Výrobok je koncipovaný výhradne pre pitnú vodu!

## **Popis symbolov**



Nepoužívať silikón s obsahom kyseliny octovej!



**Obsluha** (viď strana 66)



**Čistenie**

nájdete v priloženej brožúre.

**max. Safety Function** (viď strana 62)  
≈ 42 °C

Vďaka Safety Function je možné vopred nastaviť najvyššiu požadovanú teplotu, napr. max. 42 °C.



**Nastavenie** (viď strana 62)

Po ukončení montáže sa musí skontrolovať teplota vody vytekajúcej z termostatu. Pokiaľ sa teplota nameraná na mieste odberu líši od teploty nastavenej na termostate, je nutné vykonať korekciu.



**Údržba** (viď strana 64)

- Aby bol zaistený ľahký chod regulačnej jednotky, mal by sa termostat z času na čas nastaviť na maximálne horúcu a maximálne studenú vodu.
- Batéria je vybavená spätným uzáverom. Pri spätných ventiloch sa musí podľa DIN EN 1717 v súlade s národnými alebo regionálnymi predpismi testovať ich funkčnosť (aspoň raz ročne).



**Servisné diely** (viď strana 68)

XXX = kód povrchovej úpravy  
000 = chróm  
400 = biela/chróm



**Osvedčenie o skúške** (viď strana 66)



**Rozmery** (viď strana 67)



**Diagram prietoku**

(viď strana 67)

- ① Odtok vane
- ② Odtok sprchy

<b>Porucha</b>	<b>Príčina</b>	<b>Pomoc</b>
Málo vody	<ul style="list-style-type: none"> <li>- Nízky tlak v prívode.</li> <li>- Zanesený lapač nečistôt v regulačnej jednotke</li> <li>- Sítko v tesnení sprchy je znečistené</li> </ul>	<ul style="list-style-type: none"> <li>- Skontrolovať tlak v potrubí</li> <li>- Vyčistiť filter pred termostatom a na regulačnej jednotke</li> <li>- Vyčistiť sítko tesnení medzi sprchou a hadicou</li> </ul>
Kríženie tokov, teplá voda sa pri uzavretej armatúre tlačí do prívodu studenej alebo naopak	<ul style="list-style-type: none"> <li>- Znečistený alebo netesný spätný ventil</li> </ul>	<ul style="list-style-type: none"> <li>- Spätný ventil vyčistiť, prípadne vymeniť</li> </ul>
Teplota na výtoku nesúhlasí s nastavenou teplotou	<ul style="list-style-type: none"> <li>- Nebol nastavený termostat</li> <li>- Nízka teplota teplej vody</li> </ul>	<ul style="list-style-type: none"> <li>- Nastaviť termostat</li> <li>- Teplotu teplej vody zvýšiť na 42°C až 65°C</li> </ul>
Nie je možné regulovať teplotu	<ul style="list-style-type: none"> <li>- Regulačná jednotka teploty znečistená alebo zanesená vodným kameňom.</li> <li>- Pri novej inštalácii: naopak pripojené základné teleso (má byť studená vpravo, teplá vľavo) alebo zabudované otočené o 180°</li> </ul>	<ul style="list-style-type: none"> <li>- Regulačnú jednotku teploty vyčistiť, prípadne vymeniť</li> <li>- Funkčný blok zabudovať o 180°</li> </ul>
Tlačidlo bezpečnostnej poistky je nefunkčné	<ul style="list-style-type: none"> <li>- Vadná pružina</li> <li>- Tlačidlo zanesené vodným kameňom</li> </ul>	<ul style="list-style-type: none"> <li>- Pružinu alebo tlačidlo vyčistiť a zľahka potrieť tukom, prípadne vymeniť</li> </ul>
Prepínanie funguje ťažko	<ul style="list-style-type: none"> <li>- Kartuša je poškodená</li> </ul>	<ul style="list-style-type: none"> <li>- Vymeniť kartušu</li> </ul>
Netesný prepínač	<ul style="list-style-type: none"> <li>- Nečistota alebo usadeniny v sedle tesnenia</li> </ul>	<ul style="list-style-type: none"> <li>- Vyčistiť tesniace sedlo alebo vymeniť prepínač</li> </ul>





## 安全技巧

- △ 装配时为避免挤压和切割受伤，必须戴上手套。
- △ 淋浴系统只允许作为洗浴、卫生和洁身之用。
- △ 不得让儿童和肢体、精神和/或意识有障碍的成人在不受监管的情况下使用淋浴系统。受酒精或毒品影响的人员不得使用淋浴系统。
- △ 冷热水管间过大的压力差必须予以平衡。

## 安装提示

- 必须按照现行的规定安装，冲洗和测试产品！
- 安装前必须检查产品是否受到运输损害。安装后将不认可运输损害或表面损伤。

## 技术参数

工作压力:	最大 1 MPa
推荐工作压力:	0,1 - 0,5 MPa
测试压强:	1,6 MPa
(1 MPa = 10 bar = 147 PSI)	
热水温度:	最大 80°C
推荐热水温度:	65°C
热力消毒:	最大 70°C / 4 分钟

自动防止回流

该产品专为饮用水设计！

## 符号说明



请勿使用含有乙酸的硅！



操作 (参见第 66 页)



清洗

附有小手册

## max. 安全功能 (参见第 62 页)

≈ 42°C

恒温阀芯的安全功能可以预先设定所希望的最高出水温度，例如最高温度为 42°C



## 校准 (参见第 62 页)

安装完成后必须检查调温器的出水温度。如在取水处测量所得的温度与调温器上设定的温度有偏差，那么必须进行调整。



## 保养 (参见第 64 页)

- 为了保证恒温器的稳定运转，请务必定期从最热到最冷转动调温器。
- 此恒温龙头带有单向阀。单向阀必须在符合国家或当地的法律的情况下按照 DIN EN 1717 定期检查（至少一年一次）。



## 备用零件 (参见第 68 页)

XXX = 颜色代码

000 = 镀铬

400 = 白色/镀铬



## 检验标记 (参见第 66 页)





大小 (参见第 67 页)

流量示意图  
(参见第 67 页)

- ① 面盆盆管
- ② 莲蓬头盆管





问题	原因	补救
龙头出水量小	- 水压不足	- 检查总水压
	- 调压器过滤网脏污	- 清洁龙头前面和MTC恒温阀芯的过滤网。
	- 花洒滤网有垃圾堵塞	- 清洗花洒和软管间的过滤密封件
串水，在龙头关闭的状态下，热水被强迫流入冷水管路，或者相反。	- 单向阀有垃圾堵塞或漏水	- 清洗单向阀，如有必要则更换新的
龙头出水温度和温度设定的不符	- 恒温器未被调节	- 调节恒温器
	- 热水温度过低	- 将热水温度从42C升高到65C
水温无法调节	- 温度调节器脏污或结垢	- 清洁温度调节器，视需要更换
	- 对于新的安装：基体连接不正确（可能是：右冷，左热）或者安装时旋转180	- 安装功能块时，旋转180
安全停止按钮不工作	- 弹簧损坏	- 清洁弹簧和/或按钮，并视需要更换
	- 按钮僵化	
分流器不灵活	- 滤筒损坏	- 更换滤筒
分流器泄漏	- 密封位置上的脏物或沉积物	- 清洁阀座或更换分流器



安装 参见第 60 页



## Указания по технике безопасности

-  Во время монтажа следует надеть перчатки во избежание прищемления и порезов.
-  Изделие разрешается использовать только в гигиенических целях: для принятия ванны и личной гигиены.
-  Дети, а также взрослые с физическими, умственными и/или сенсорными недостатками должны пользоваться изделием только под присмотром. Запрещается пользоваться изделием в состоянии алкогольного или наркотического опьянения.
-  донного клапа. Перед установкой смесителя необходимо регулировочными кранами выровнять давление холодной и горячей воды при помощи вентилей регулирующих подачу воды в квартиру.

## Указания по монтажу

- Смеситель должен быть смонтирован по действующим нормам и в соответствии с настоящей инструкцией, проверен на герметичность и безупречность работы
- Перед монтажом следует проверить изделие на предмет повреждений при перевозке. После монтажа претензии о возмещении ущерба за повреждения при перевозке или повреждения поверхностей не принимаются.

## Технические данные

Рабочее давление:	не более. 1 МПа
Рекомендуемое рабочее давление:	0,1 - 0,5 МПа
Давление:	1,6 МПа
(1 МПа = 10 bar = 147 PSI)	
Температура горячей воды:	не более. 80 °С
Рекомендуемая темп. гор. воды:	65 °С
Термическая дезинфекция:	не более. 70 °С / 4 мин

укомплектован клапаном обратного тока воды

Изделие предназначено исключительно для питьевой воды!

## Описание символов



Не применяйте силикон, содержащий уксусную кислоту.



### Эксплуатация (см. стр. 66)



### Очистка

см прилагаемая брошюра

## max. Safety Function (см. стр. 62)

≈ 42 °С

С помощью функции Safety Function может быть задана максимальная температура воды, например 42° С.



## Настройка (см. стр. 62)

После монтажа следует проверить температуру на выходе из термостата. Скорректируйте температуру воды, если она отличается от установленной на термостате.



## Техническое обслуживание (см. стр. 64)

- Для гарантии плавного изменения температуры и долгого срока службы необходимо периодически поворачивать ручку регулировки температуры из положение максимально горячая в положение максимально холодная вода.
- Термостат оснащен клапанами обратного течения. Защита обратного тока должна регулярно проверяться (минимум один раз в год) по стандарту DIN EN 1717 или в соответствии с национальными или региональными нормативами



## Комплект (см. стр. 68)

XXX = Код цвета поверхности  
000 = хром  
400 = белый/хром



## Знак технического контроля (см. стр. 66)



**Размеры** (см. стр. 67)



**Схема потока**

(см. стр. 67)





- ① Отвод ванны
- ② Отвод душа

<b>Неисправность</b>	<b>Причина</b>	<b>Устранение неисправности</b>
недостаточный давление (если устан напор воды)	- Проблемы водоснабжения	- Проверить овлен насос проверить работу насоса
	- Фильтр термоэлемента загрязнен	- Очистите грязеулавливающие сита перед термостатом и на регуляторе
	- Фильтр душа загрязнен	- Очистить фильтр
Подмес воды, в закрытом положении горячая вода стремится в подводку холодной воды или наоборот	- Клапан обратного тока воды загрязнен или неисправен	- Очистить кланан или заменить при необходимости
Температура смешанной воды не соответствует шкале	- Термостат не настроен	- Настроить термостат
	- Температура горячей воды слишком низкая	- Поднять температуру горячей воды с 42 град.С до 65 град.С
Регулировка температура не производится	- Термоэлемент загрязнен или открыт известью	- Очистить термоэлемент при необходимости заменить термоэлемент
	- для вновь установленного изделия: ошибка установки, холодная вода подводится справа горячая слева, или установлено с 180 град поворотом.	- повернуть внутренний блок
Красная кнопка защиты от ожога не работает	- Износ пружины кнопки	- Очистите пружину или кнопку и слегка смажьте, при необходимости замените
	- Заизвесткованность кнопки	
Переключатель заедает	- Картридж неисправен	- Замените картридж
Переключатель негерметичен	- Загрязнения или отложения на основании уплотнения	- Очистите уплотнительное кольцо или замените переключатель





## Biztonsági utasítások

-  A szerelésnél a zúzódások és vágási sérülések elkerülése érdekében kesztyűt kell viselni.
-  A terméket csak fürdéshez, mosakodáshoz, és egészségügyi tisztálkodáshoz szabad használni.
-  Gyermekek, valamint testileg, szellemileg fogyatékos és / vagy érzékelésben korlátozott személyek nem használhatják felügyelet nélkül a terméket. Alkohol és kábítószer befolyása alatt álló személyek nem használhatják a terméket.
-  A hidegvíz- és a melegvíz-csatlakozások közötti nagy nyomáskülönbséget kell egyenlíteni!

## Szerelési utasítások

- A csaptelepet az érvényben lévő előírásoknak megfelelően kell felszerelni, átöblíteni és ellenőrizni!
- A szerelés előtt ellenőrizni kell, hogy a terméknek nincs-e szállítási sérülése. Beépítés után a szállítási-vagy felületi sérüléseket nem ismerik el.

## Műszaki adatok

Üzemi nyomás:	max. 1 MPa
Ajánlott üzemi nyomás:	0,1 - 0,5 MPa
Nyomáspróba:	1,6 MPa
(1 MPa = 10 bar = 147 PSI)	
Forróvíz hőmérséklet:	max. 80 °C
Forróvíz javasolt hőmérséklete:	65 °C
Termikus fertőtlenítés:	max. 70 °C / 4 perc

Visszafolyás gátlóval

A terméket kizárólag ivóvízhez tervezték!

**max. Safety Function** (Biztonsági funkció) (lásd a 62. oldalon)  
**≈ 42 °C**

A biztonsági funkcióknak köszönhetően a kívánt hőmérsékletet pl. 42 Celsius fokban maximálhatjuk.



## Beszerezés (lásd a 62. oldalon)

A sikeres felszerelést követően ellenőrizni kell a termosztát kifolyási hőmérsékletét. Helyesbítés szükséges, ha a vízkivétel helyén mért hőmérséklet eltér a termosztáton beállított hőmérséklettől.



## Karbantartás (lásd a 64. oldalon)

- Ahhoz, hogy a szabályozóegység jól működjön, a termosztátot időről időre teljesen megrege és teljesen hidegre kell állítani.
- A termosztát visszafolyás-gátlóval van felszerelve. A visszafolyás-gátlók működése a DIN EN 1717 szabványnak megfelelően, a nemzeti vagy területi rendelkezésekkel összhangban, évente egyszer ellenőrizendő!



## Tartozékok (lásd a 68. oldalon)

XXX = Színkódok  
 000 = króm  
 400 = fehér/króm

## Szimbólumok leírása



Ne használjon ecetsavtartalmú szilikon!



**Használat** (lásd a 66. oldalon)



**Tisztítás**

lásd a mellékelt brosúrát.



**Vizsgajel** (lásd a 66. oldalon)



**Méretet** (lásd a 67. oldalon)



**Átfolyási diagramm**

(lásd a 67. oldalon)

- ① Kád lefolyója
- ② Zuhany lefolyója

Hiba	Ok	Megoldás
Kevés víz	<ul style="list-style-type: none"> <li>- a nyomás nem megfelelő</li> <li>- a szabályozóegység szennyeződést felfogó szűrője koszos</li> <li>- A zuhany szűrőtömitése koszos</li> </ul>	<ul style="list-style-type: none"> <li>- a vezetékek nyomását ellenőrizni kell</li> <li>- A termosztát előtt és a szabályozó egységen lévő szennyező szűrők megtisztítása</li> <li>- A zuhany és a cső közötti szűrőt ki kell tisztítani</li> </ul>
Kereszfolyás, a melegvíz a csap zárt állapotában a hidegvíz vezetékbe áramlik és fordítva	<ul style="list-style-type: none"> <li>- a visszafolyásgátló piszkos vagy hibás</li> </ul>	<ul style="list-style-type: none"> <li>- a visszafolyásgátlót tisztítani kell ill. ki kell cserélni</li> </ul>
A kifolyóvíz hőmérséklete nem egyezik a termosztáton beállított hőmérséklettel	<ul style="list-style-type: none"> <li>- a termosztát nem lett beszabályozva</li> <li>- túl alacsony melegvíz hőmérséklet</li> </ul>	<ul style="list-style-type: none"> <li>- a termosztátot be kell szabályozni</li> <li>- a melegvíz hőmérsékletét 65 fokra kell felemelni</li> </ul>
Nem lehetséges a hőmérséklet-szabályozás	<ul style="list-style-type: none"> <li>- a hőmérséklet szabályozóegység koszos vagy vízköves</li> <li>- Újrainstallálásnál az alaptest rosszul csatlakozik (a hideget jobbra, a meleget balra vagy 180 fokkal elforgatva kell beszerelni)</li> </ul>	<ul style="list-style-type: none"> <li>- a szabályozó egységet tisztítani ill cserélni kell</li> <li>- A funkcióblokkot 180 fokkal való elforgatás után beszerelni.</li> </ul>
A biztonsági zár nyomógombja nem működik	<ul style="list-style-type: none"> <li>- a rugó hibás</li> <li>- a nyomógomb vízköves</li> </ul>	<ul style="list-style-type: none"> <li>- a rugót ill. a nyomógombot ki kell tisztítani és enyhén be kell zsírozni ill. ki kell cserélni</li> </ul>
Átváltószelep nehezen mozog.	<ul style="list-style-type: none"> <li>- A kerámiabetét meghibásodott.</li> </ul>	<ul style="list-style-type: none"> <li>- A kerámiabetétet ki kell cserélni.</li> </ul>
Az átváltószelep nem szigetel	<ul style="list-style-type: none"> <li>- Szennyeződések vagy lerakódások a tömítésnél.</li> </ul>	<ul style="list-style-type: none"> <li>- Tömítés vagy az átváltószelep cseréje szükséges</li> </ul>



**Szerelés lásd a 60. oldalon**



## Turvallisuusohjeet

- △ Asennuksessa on käytettävä käsiineitä puristumien ja viiltojen aiheuttamien tapaturmien estämiseksi.
- △ Suihkujärjestelmää saa käyttää ainoastaan kylpy-, hygienia- ja puhdistustarkoituksiin.
- △ Lapset ja ruumiillisesti, henkisesti ja/tai aistillisesti rajoittuneet aikuiset eivät saa käyttää suihkujärjestelmää ilman valvontaa. Alkoholien tai huumeiden vaikutuksessa olevat henkilöt eivät saa käyttää suihkujärjestelmää.
- △ Suuret paine-erot kylmä- ja kuumavesiliitäntöjen välillä on tasattava.

## Asennusohjeet

- Kaluste on asennettava, huuhdeltava ja tarkastettava voimassa olevien määräysten mukaisesti!
- Ennen asennusta on tarkastettava tuotteen mahdolliset kuljetusvahingot. Asennuksen jälkeen kuljetus- ja pintavaurioita ei hyväksytä.

## Tekniset tiedot

Käyttöpaine:	maks. 1 MPa
Suosittelut käyttöpaine:	0,1 - 0,5 MPa
Koestuspaine:	1,6 MPa
(1 MPa = 10 bar = 147 PSI)	
Kuuman veden lämpötila:	maks. 80 °C
Kuuman veden suosituslämpötila:	65 °C
Lämpödesinfektio:	maks. 70 °C / 4 min

Estää itsestään paluuvirtauksen

Tuote on suunniteltu käytettäväksi ainoastaan juomaveden kanssa!

## Merkin kuvaus



Älä käytä etikkahappopitoista silikonia!



### Käyttö (katso sivu 66)



### Puhdistus

katso oheinen esite

**max. Safety Function** (katso sivu 62)  
≈ 42 °C

Safety Function:ista johtuen haluttu maksimilämpötila voidaan esiasettaa, esimerkiksi maks. 42° C.



### Säätö (katso sivu 62)

Asennuksen jälkeen termostaatin ulostulolämpötila on tarkastettava. Säätö on tarpeen, jos käyttöpisteessä mitattu veden lämpötila eroaa termostaattiin säädetyistä lämpötilasta.



### Huolto (katso sivu 64)

- Säätöyksikön kevytkäyttöisyyden takaamiseksi, säädä säätöyksikkö ajoittain täysin kylmälle ja täysin kuumalle.
- Termostaatti on varustettu vastaventtiileillä. Vastaventtiilien toiminta on tarkastettava säännöllisesti paikallisten ja kansallisten määräysten mukaisesti (DIN EN 1717, vähintään kerran vuodessa).



### Varaosat (katso sivu 68)

XXX = Värikoodi  
000 = kromi  
400 = valkoinen/kromi



### Koestusmerkki (katso sivu 66)



## Mitat (katso sivu 67)



## Virtausdiagrammi

(katso sivu 67)

- ① Ammeen lähtö
- ② Suihkun lähtö

Häiriö	Syy	Toimenpide
Vähän vettä	- Syöttöpaine ei ole riittävä - Lämpötilan säätöyksikön likasihti likaantunut - Käsisiuhkun sihtitiiviste likaantunut	- Tarkasta putkiston paine - Puhdista termostaatin ja säätöyksikön likasihdit - Puhdista suihkukahvan ja letkun välissä oleva sihtitiiviste
Ristiinvirtaus, hanan ollessa kiinni lämmin vesi pääsee virtaamaan kylmänveden putkeen tai päinvastoin.	- Suuntaisventtiili likaantunut / viallinen	- Puhdista suuntaisventtiili, vaihda tarvittaessa
Veden ulostulolämpötila ei vastaa säädettyä lämpötilaa	- Termostaattia ei ole säädetty - Lämminveden lämpötila liian alhainen	- Sääädä termostaatti - Kohota lämminveden lämpötila arvoon välillä 42°C ja 65°C
Lämpötilan säätö ei ole mahdollista	- Lämpötilansäätöyksikkö likaantunut tai kalkkeutunut - Liitokset perusrunkoon on asennettaessa tehty väärin (pitää olla: kylmä oikealla, lämmin vasemmalla) tai perusrunko on asennettu 180°-käännettynä	- Puhdista lämpötilansäätöyksikkö, vaihda tarvittaessa - Asenna toimintalohko 180° käännettynä paikalleen
Veden lämpötilan turvarajoittimen painonappi ei toimi	- Jousi ei toimi - Painonappi on kalkkeutunut	- Puhdista ja voitele kevyesti jousi ja/ tai painonappi, vaihda tarvittaessa
Valitsin raskaskäyttöinen	- Patruuna rikki	- Vaihda patruuna
Valitsin vuotaa	- Likaa tai kerrostumia tiivisteistukassa	- Puhdista tiiviste tai vaihda suihkulajin valitsin





## **Säkerhetsanvisningar**

- △ Handskar ska bäras under monteringsarbetet så att man kan undvika kläm- och skärskadorgen werden.
- △ Produkten får bara användas till kroppshygien med bad och dusch.
- △ Barn samt vuxna med fysiska, psykiska eller sensoriska funktionshinder får inte använda produkten ensamma. Personer som är påverkade av alkohol- eller droger får inte använda produkten.
- △ Stora tryckskillnader mellan anslutningarna för varmt och kallt vatten måste utjämnas.

## **Monteringsanvisningar**

- Blandaren måste installeras, genomspolas och testas enligt gällande föreskrifter.
- Det måste undersökas om produkten har transportskador innan den monteras. Efter monteringen accepteras inga transport- eller ytskiktsskador.

## **Tekniska data**

Driftstryck:	max. 1 MPa
Rek. driftstryck:	0,1 - 0,5 MPa
Tryck vid provtryckning: (1 MPa = 10 bar = 147 PSI)	1,6 MPa
Varmvattentemperatur:	max. 80 °C
Rek. varmvattentemp.:	65 °C
Termisk desinfektion:	max. 70 °C / 4 min

Självspärr mot återflöde

Produkten är enbart avsedd för dricksvatten!

## **max. Safety Function** (se sidan 62) **≈ 42 °C**

Med hjälp av Safety Function kan du ställa in den önskade maximaltemperaturen till exempelvis 42 °C och så förhindra skällningsrisk för barn.



## **Inställning av maxtemperatur** (se sidan 62)

När monteringen är klar måste termostatsens tömningstemperatur kontrolleras. En justering är nödvändig om den uppmätta temperaturen vid tappningsstället avviker från den som är inställd på termostaten.



## **Skötsel** (se sidan 64)

- För att garantera att termostaten ej kalkar igen, ska den regelbundet, en gång per vecka, konditioneras. Det sker genom att man några gånger snabbt slås om temperaturen från hett till kallt och tillbaka.
- Termostaten är utrustad med backventiler. Backventilers funktion måste kontrolleras regelbundet enligt nationella eller regionala bestämmelser i enlighet med DIN EN 1717 (minst en gång per år).



## **Reservdelar** (se sidan 68)

XXX = Färgkodning  
000 = krom  
400 = vit/krom

## **Symbolförklaring**



Använd inte silikon som innehåller ättiksyra!



**Hantering** (se sidan 66)



**Rengöring**

se den medföljande broschyren



**Testsigill** (se sidan 66)



**Måtten** (se sidan 67)**Flödesschema**

(se sidan 67)





- ① Avlopp kar
- ② Avlopp dusch

<b>Störning</b>	<b>Orsak</b>	<b>Åtgärd</b>
För lite vatten	<ul style="list-style-type: none"> <li>- Vattentrycket är för lågt</li> <li>- Smutsfilter i styrenheten igensatt</li> <li>- Silfiltret i duschen smutsigt</li> </ul>	<ul style="list-style-type: none"> <li>- Kontrollera ledningstryck</li> <li>- Rengör smutsfiltren vid inloppen och på termosensorn</li> <li>- Rengör silfiltret mellan slangen och termostaten</li> </ul>
Korsflöde – varmt vatten pressas vid avstängd ermostat in i kallvatteninloppet, och vice versa	- Backventil är igensmutsad eller otät	- Rengör backventil, byt ut om nödvändigt
Den faktiska vatten-temperaturen stämmer inte överens med den inställda	<ul style="list-style-type: none"> <li>- Termostaten ställdes inte in</li> <li>- Varmvattentemperaturen är för låg</li> </ul>	<ul style="list-style-type: none"> <li>- Justera termostaten</li> <li>- Höj varmvattentemperaturen till mellan 42°C och 65°C</li> </ul>
Temperaturen kan ej ställas in	<ul style="list-style-type: none"> <li>- Temperaturinställning smutsig eller täckt av kalk</li> <li>- Grundkonstruktionen anslöts på fel sätt vid nyinstallation (ska vara: kallt höger, varmt vänster) eller monterades med 180° förskjutning</li> </ul>	<ul style="list-style-type: none"> <li>- Rengör temperaturinställningen, byt ut om nödvändigt</li> <li>- Montera funktionsblocket med 180° förskjutning</li> </ul>
Tryckknappen till säkerhetspärren har ingen funktion	<ul style="list-style-type: none"> <li>- Fjäder defekt</li> <li>- Tryckknapp förkalkad</li> </ul>	- Rengör fjäder eller tryckknapp och smörj in något, eller byt ut om detta behövs
Omkopplare trög	- Patron defekt	- Byt ut patron
Omkopplare otät	- Smuts eller avlagringar på packningen	- Rengör packning eller byt ut omkopplare.

**Montering se sidan 60**



## Saugumo technikos nurodymai

-  Apsaugai nuo užspaudimo ir įsipjovimo montavimo metu mūvėkite pirštines.
-  Gaminys turi būti naudojamas tik maudymuisi, kūno higienai ir švarai palaikyti.
-  Gaminių draudžiama naudotis vaikams, taip pat suaugusiems su fizine, dvasine negale ir (arba) sensorikos sutrikimais. Gaminių taip pat draudžiama naudotis asmenims, apsvaigusiems nuo alkoholio arba narkotikų.
-  Turi būti išlyginti šalto ir karšto slėgio nelygumai.

## Montavimo instrukcija

- Maišytuvą privalo būti montuojamas, išleidžiamas ir patikrinamas pagal galiojančias normas!
- Prieš montuojant būtina patikrinti, ar gaminyje nebuvo pažeistas transportavimo metu. Sumontavus pretenzijos dėl transportavimo ir paviršiaus pažeidimų nepriimamos.

## Techniniai duomenys

Darbinis slėgis: ne daugiau kaip 1 MPa  
 Rekomenduojamas slėgis: 0,1 - 0,5 MPa  
 Bandomasis slėgis: 1,6 MPa  
 (1 MPa = 10 barų = 147 PSI)  
 Karšto vandens temperatūra: ne daugiau kaip 80°C  
 Rekomenduojama karšto vandens temperatūra: 65°C  
 Terminis dezinfekavimas: ne daugiau kaip 70°C / 4 min

Su atbuliniu vožtuvu

Produktas skirtas tik geriamajam vandeniui!

## Simbolio aprašymas



Nenaudokite silikono, kurio sudėtyje yra acto rūgšties!



**Eksplotacija** (žr. psl. 66)



**Valymas**

žr. pridedamoje brošiūroje.

**max. Apsaugos funkcija** (žr. psl. 62)  
 ≈ 42°C

“Safety” funkcija karšto vandens temperatūra gali būti iš anksto ribota iki, pvz., ne aukštesnės kaip 42°C.



**Nustatymas** (žr. psl. 62)

Sumontavus, būtina patikrinti vandens, išeinančio iš termostato, temperatūrą. Pakoreguokite vandens temperatūrą, jei būtina.



**Techninis aptarnavimas** (žr. psl. 64)

- Tam, kad būtų garantuotas tolygus temperatūros reguliavimas ir ilgas naudojimas, būtina periodiškai temperatūros rankenėlę pasukti į karščiausios ir šalčiausios temperatūros padėtį.
- Termostatas yra su grįžtamąsios srovės sustabdymo vožtuvais. Atbulinio vožtuvo apsauga privalo būti tikrinama reguliariai (mažiausiai kartą per metus) pagal DIN EN1717 arba pagal galiojančias nacionalines arba regionines normas.



**Atsarginės dalys** (žr. psl. 68)

XXX = Spalva  
 000 = chrom  
 400 = balta/chrom



**Bandymo pažyma** (žr. psl. 66)



## Išmatavimai (žr. psl. 67)



## Pralaidumo diagrama

(žr. psl. 67)





- ① Vonios išleidimas
- ② Dušo išleidimas

Gedimas	Priežastis	Priemonė
Per maža srovė	<ul style="list-style-type: none"> <li>- Slėgis nepakankamas</li> <li>- Užsikimšęs temperatūros reguliatoriaus filtras</li> <li>- Dušo galvos filtras užsikimšęs</li> </ul>	<ul style="list-style-type: none"> <li>- Patikrinti vamzdžių spaudimą</li> <li>- Išvalyti termostato ir temperatūros reguliatoriaus filtrus</li> <li>- Išvalyti dušo galvos filtrą</li> </ul>
Kryžminis tekėjimas, uždarius maišytuvą, karštas vanduo papuola į šalto vandens vamzdį	- Atbulinis vožtuvas užsikimšęs / pažeistas	- Išvalyti arba pakeisti atbulinį vožtuvą
Vandens temperatūra nesutampa su nustatyta temperatūra	<ul style="list-style-type: none"> <li>- Termostatas nereguliuotas</li> <li>- Per maža karšto vandens temperatūra</li> </ul>	<ul style="list-style-type: none"> <li>- Reguluoti termostatą</li> <li>- Karšto vandens temperatūrą pakelti nuo 42 °C bis 65 °C</li> </ul>
Temperatūros reguliavimas neįmanomas	<ul style="list-style-type: none"> <li>- Temperatūros reguliatorius užsikimšęs arba apkalkėjęs</li> <li>- Neteisingai prijungti vamzdžiai: karštas turi būti kairėje, šaltas - dešinėje</li> </ul>	<ul style="list-style-type: none"> <li>- Išvalyti arba pakeisti temperatūros reguliatorių</li> <li>- Sumontuoti funkcijos blokavimą 180°</li> </ul>
Ribotuvo mygtukas neveikia	<ul style="list-style-type: none"> <li>- Spyruoklė pažeista</li> <li>- Mygtukas apkalkėjęs</li> </ul>	- Išvalyti spyruoklę/mygtuką ir sutepti arba keisti
Perjungėjas sunkiai valdomi	- Kasetė pažeista	- Pakeisti kasetę
Perjungėjas nesandarus	- Purvas arba apnašos ant sandariklio paviršiaus	- Išvalyti arba pakeisti perjungklį





## Sigurnosne upute

-  Prilikom montaže se radi sprječavanja prignječenja i posjekotina moraju nositi rukavice.
-  Proizvod se smije primjenjivati samo za kupanje, tuširanje i osobnu higijenu.
-  Djeca, kao i tjelesno, mentalno i/ili senzorno hendikepirane odrasle osobe ne smiju se koristiti proizvodom bez nadzora. Osobe koje su pod utjecajem alkohola ili droga ne smiju se koristiti proizvodom.
-  Velika razlika u pritisku između vruće i hladne vode mora biti izbalansirana.

## Upute za montažu

- Cijevi moraju biti postavljene, isprane i testirane prema važećim normama!
- Prije montaže mora se provjeriti je li proizvod oštećen prilikom transporta. Nakon ugradnje se ne priznaju nikakve reklamacije koje se odnose na površinska i transportna oštećenja.

## Tehnički podaci

Najveći dopušteni tlak:	tlak 1 MPa
Preporučeni tlak:	0,1 - 0,5 MPa
Probni tlak:	1,6 MPa
(1 MPa = 10 bar = 147 PSI)	
Temperatura vruće vode:	tlak 80 °C
Preporučena temperatura vruće vode:	65 °C
Termička dezinfekcija:	tlak 70 °C / 4 min

Funkcije samo-čišćenja

Proizvod je koncipiran isključivo za pitku vodu!

## Opis simbola



Nemojte koristiti silikon koji sadrži octenu kiselinu!



**Upotreba** (pogledaj stranicu 66)



**Čišćenje**

se u priloženoj brošuri.

**max. Safety Funkcija** (pogledaj stranicu 62)  
≈ 42 °C

Zahvaljujuću Safety funkciji može se podesiti željena maksimalna temperatura, npr. i 42 °C



**Regulacija** (pogledaj stranicu 62)

Nakon instalacije treba ispitati izlaznu temperaturu termostata. Korekcija je neophodna, ako izmjerena temperatura na mjestu uzimanja odstupa od temperature koja je namještena na termostatu.



**Održavanje** (pogledaj stranicu 64)

- Kako bi se olakšala prohodnost i produljio vijek trajanja regulacijske jedinice, potrebno je s vremena na vrijeme podesiti termostat iz položaja maksimalno tople u položaj maksimalno hladne vode.
- Termostat je opremljen nepovratnim ventilom. Ispravnost nepovratnog ventila mora se redovito provjeravati prema standardu DIN EN 1717 i u skladu sa važećim propisima (najmanje jednom godišnje).



**Rezervni djelovi** (pogledaj stranicu 68)

XXX = Boje  
000 = krom  
400 = bijela/krom



**Oznaka testiranja** (pogledaj stranicu 66)



**Mjere** (pogledaj stranicu 67)



**Dijagram protoka**  
(pogledaj stranicu 67)

- ① Ogranak kada
- ② Ogranak tuš

<b>Greška</b>	<b>Uzrok</b>	<b>Otklanjanje</b>
Nedovoljno vode	<ul style="list-style-type: none"> <li>- Prenizak pritisak vode</li> <li>- Očistite rešetkasti filter regulacijske jedinice</li> <li>- Filter tuša je prljav</li> </ul>	<ul style="list-style-type: none"> <li>- Ispitajte tlak u cijevima</li> <li>- Očistite rešetkasti filter ispred termostata i na regulacijskoj jedinici</li> <li>- Očistite filter između tuša i crijeva</li> </ul>
Križni tok vode, kod zatvorene armature vruća voda ulazi u cijev s hladnom vodom i obrnuto	<ul style="list-style-type: none"> <li>- Nepovratni ventil je prljav/neispravan</li> </ul>	<ul style="list-style-type: none"> <li>- Očistite ili zamijenite nepovratni ventil</li> </ul>
Temperatura na slavini ne podudara se s podešenom temperaturom	<ul style="list-style-type: none"> <li>- Termostat nije podešen</li> <li>- Preniska temperatura tople vode</li> </ul>	<ul style="list-style-type: none"> <li>- Podesite termostat</li> <li>- Povećajte temperaturu vruće vode na 42-65 °C</li> </ul>
Reguliranje temperature nije moguće	<ul style="list-style-type: none"> <li>- Regulator temperature je prljav ili obložen naslagama kamenca</li> <li>- Pri ponovnoj instalaciji tijelo je pogrešno priključeno (potrebno je priključiti hladnu vodu desno, a vruću lijevo) ili je zakrenuto za 180 stupnjeva.</li> </ul>	<ul style="list-style-type: none"> <li>- Očistite ili zamijenite regulator temperature.</li> <li>- Unutarnji blok okrenite za 180 stupnjeva</li> </ul>
Tipkalo sigurnosnog prekida je van funkcije	<ul style="list-style-type: none"> <li>- Opruga je neispravna</li> <li>- Tipkalo je začepljeno slojem kamenca</li> </ul>	<ul style="list-style-type: none"> <li>- Očistite i podmažite oprugu, tj. tipkalo, u slučaju potrebe tipkalo možete zamijeniti novim</li> </ul>
Selektor je neprohodan	<ul style="list-style-type: none"> <li>- Neispravan uložak</li> </ul>	<ul style="list-style-type: none"> <li>- Zamijenite uložak</li> </ul>
Selektor ne brtvi	<ul style="list-style-type: none"> <li>- Prljavština ili naslage kamenca na sjedištima brtvila</li> </ul>	<ul style="list-style-type: none"> <li>- Očistite ventile ili zamijenite selektor</li> </ul>





## ⚠ Güvenlik uyarıları

- ⚠ Montaj esnasında ezilme ve kesilme gibi yaralanmaları önlemek için eldiven kullanılmalıdır.
- ⚠ Duş sistemi yalnızca banyo, hijyen ve beden temizliği amaçları doğrultusunda kullanılabilir.
- ⚠ Bedensel, ruhsal ve/veya sensörük engelli çocuk ve yetişkinler gözetimsiz olarak duş sistemini kullanmamalıdır. Alkol veya uyuşturucu etkisinde olanlar duş sistemini kullanmamalıdır.
- ⚠ Sıcak ve soğuk su bağlantıları arasında büyük basınç farklılıkları varsa, bu basınç farklılıklarının dengelenmesi gerekir.

## Montaj açıklamaları

- Batarya geçerli normlara göre monte edilmeli, yıkanmalı ve kontrol edilmelidir!
- Montaj işleminden önce ürün nakliye hasarları yönünden kontrol edilmelidir. Montaj işleminden sonra nakliye veya yüzey hasarları için sorumluluk üstlenilmemektedir.

## Teknik bilgiler

İşletme basıncı:	azami 1 MPa
Tavsiye edilen işletme basıncı:	0,1 - 0,5 MPa
Kontrol basıncı:	1,6 MPa
(1 MPa = 10 bar = 147 PSI)	
Sıcak su sıcaklığı:	azami 80°C
Tavsiye edilen su ısısı:	65°C
Termik dezenfeksiyon:	azami 70°C / 4 dak

Geri emme önleyici

Ürün sadece şebeke suyu için tasarlanmıştır!

## Simge açıklaması



Asetik asit içeren silikon kullanmayın!



**Kullanımı** (Bakınız sayfa 66)



**Temizleme**

birlikte verilen broşür

**max. Safety Function** (Bakınız sayfa 62)  
≈ 42°C

Emniyet fonksiyonu sayesinde, istenen maksimum sıcaklık Örn; maks. 42°C önceden ayarlanabilir.



**Ayarlama** (Bakınız sayfa 62)

Montaj tamamlandıktan sonra, termostatların çıkış sıcaklığı kontrol edilmelidir. Alma noktasında ölçülen sıcaklık termostatta ayarlanan sıcaklıktan farklıysa, bir düzeltme gereklidir.



**Bakım** (Bakınız sayfa 64)

- Ayar ünitesinin kolay hareket etmesini sağlamak için, termostat belirli aralıklarla tamamen sıcak ve soğuk konuma getirilmelidir.
- Termostat, çek valflerle donatılmıştır. DIN EN 1717 ve ulusal standartlar doğrultusunda Çek valfler düzenli olarak kontrol edilmelidir. ( en az yılda bir kez)



**Yedek Parçalar** (Bakınız sayfa 68)

XXX = Renkler  
000 = krom  
400 = beyaz/Krom



**Kontrol işareti** (Bakınız sayfa 66)



**Ölçüleri** (Bakınız sayfa 67)



**Akış diyagramı**  
(Bakınız sayfa 67)

- ① Tekne çıkışı
- ② Su püskürtücü çıkışı





arıza	sebeup	yardııı
Az su geliyor	- Besleme basıncı yeterli deęil - Ayar ünitesinin filtresi kirlenmiř - Duřun süzgeci tıkanmıř olabilir	- Hat basıncını kontrol edin - Termostatın önündeki ve ayar ünitesindeki filtreleri temizleyin - El duřu ile hortum arasındaki hortumu yıkayın
Çapraz akıř, batarya kapalıyken sıcak su soęuk su hattına gönderiliyor ya da tam tersi	- Çek valf kirlenmiř / arızalı	- Çek valfi temizleyin ya da deęiřtirin
Çıkıř sıcaklıęı ayarlanan sıcaklıkla aynı deęil	- Termostat ayarlanmadı - Sıcak suyun derecesi çok düşük	- Termostatı ayarlayın - Sıcak su sıcaklıęını 42 °C ila 65 °C'ye yükseltin
Sıcaklık ayarı mümkün deęil	- Sıcaklık ayar ünitesi kirlenmiř ya da kireçlenmiř - Yeni montaj sırasında ana gövde yanlış baęlanmış (Olması gereken: soęuk saę tarafa, sıcak sol tarafa) ya da 180° döndürölerek takılmıř	- Sıcaklık ayar ünitesini temizleyin, gerekirse deęiřtirin - Fonksiyon bloęunu 180° döndürerek takın
Emniyet kilidinin düęmesi çalıřmıyor	- Yay arızalı - Düęme kireçlenmiř	- Yayı ya da düęmeyi temizleyin ve hafifçe gres sürün, gerekirse deęiřtirin
Divertör zor hareket ediyor	- Kartuř bozuk olabilir	- Kartuřu deęiřtirin
Divertör sızdırıyor	- Conta yuvasında kir ya da tortu	- Conta yuvasını temizleyin veya divertörü deęiřtirin



**Montajı Bakınız sayfa 60**



## Instrucțiuni de siguranță

-  La montare utilizați mănuși pentru evitarea contuziunilor și tăierii mâinilor.
-  Sistemul de duș poate fi utilizat doar pentru spălarea, menținerea igienei și curățarea corpului.
-  Copiii și adulții cu dizabilități corporale, mintale și senzoriale nu pot utiliza sistemul de duș nesupravegheați. De asemenea este interzisă utilizarea sistemului de duș de către persoane, care se află sub influența alcoolului sau a drogurilor.
-  Diferențele de presiune mari între alimentarea cu apă rece și apă caldă trebuie echilibrate.

## Instrucțiuni de montare

- Bateria trebuie montată, clătită și verificată conform normelor în vigoare.
- Înainte de instalare verificați, dacă produsul prezintă deteriorări de transport. După instalare garanția nu acoperă deteriorările de transport și cele de suprafață.

## Date tehnice

Presiune de funcționare:	max. 1 MPa
Presiune de funcționare recomandată:	0,1 - 0,5 MPa
Presiune de verificare:	1,6 MPa
(1 MPa = 10 bar = 147 PSI)	
Temperatura apei calde:	max. 80 °C
Temperatura recomandată a apei calde:	65 °C
Dezinfecție termică:	max. 70 °C / 4 min

Asigurat contra scurgere înapoi

Produsul este destinat exclusiv pentru apă potabilă.

## Descrierea simbolurilor



Nu utilizați silcon cu conținut de acid acetic!



**Utilizare** (vezi pag. 66)



**Curățare**

vezi broșura alăturată.

**max. Funcția de siguranță** (vezi pag. 62)  
**≈ 42 °C**

Datorită funcției de siguranță puteți preregla temperatura maximă, de ex. 42 °C.



**Reglare** (vezi pag. 62)

După montare verificați temperatura de ieșire la termostat. În cazul în care există o diferență între temperatura măsurată la golire și temperatura reglată la termostat trebuie efectuată o corecție.



**Întreținere** (vezi pag. 64)

- Pentru garantarea mișcării ușoare a unității de reglare, vă recomandăm să setați termostatul pe pozițiile limită cald și rece.
- Termostatul este dotat cu supape antiretur. Supapele antiretur trebuie verificate regulat conform DIN EN 1717 și standardele naționale sau regionale (cel puțin o dată pe an).



**Piese de schimb** (vezi pag. 68)

XXX = cod de culori  
000 = crom  
400 = alb/crom



**Certificat de testare** (vezi pag. 66)





**Dimensiuni** (vezi pag. 67)



**Diagrama de debit**  
(vezi pag. 67)

- ① Orificiu de scurgere vană
- ② Orificiu de scurgere duș

<b>Deranjament</b>	<b>Cauza</b>	<b>Măsuri de remediere</b>
Prea puțină apă	- Presiune de alimentare insuficientă. - Murdărie în sita de impurități a unității de reglare. - S-a murdărit garnitura de sită a capătului de duș.	- Verificați presiunea din conducte. - Curățați sitele de impurități la intrarea termostatului și în unitatea de reglare. - Curățați garnitura sită dintre capătul duș și furtun.
Curgere încucișată, apa caldă intră în conducta de apă rece sau invers, când bateria este închisă.	- S-a murdărit / s-a defectat supapa antiretur.	- Curățați sau schimbați supapa antiretur dacă este cazul.
Temperatura apei la ieșire nu corespunde cu temperatura reglată.	- Termostatul nu a fost reglat. - Temperatura apei calde este prea mică	- Reglați termostatul. - Ridicați temperatura apei calde la o temperatură între 42 °C și 65 °C.
Temperatura nu poate fi reglată.	- Unitatea de reglare a temperaturii murdar sau cu depuneri de calcar. - Bateria a fost racordată incorect la prima instalare. (instalați rece - dreapta, cald - stânga) sau rotit cu 180°.	- Curățați sau schimbați unitatea de reglare a temperaturii dacă este cazul. - Montați invers blocul de funcții (rotit cu 180°).
Butonul de pe întrerupătorul de siguranță nu funcționează.	- Arc defect - Depuneri de calcar pe buton	- Curățați și ungeți puțin arcul și butonul sau schimbați-le dacă este cazul.
Cartușul se mișcă greu.	- Cartuș defect	- Schimbați cartușul.
Cartușul nu este etanș	- Murdărie sau depuneri pe scaunul garniturii	- Curățați sau înlocuiți scaunul inelului de etanșare sau schimbați cartușul bateriei.



**Montare vezi pag. 60**



## ⚠ Υποδείξεις ασφαλείας

- ⚠ Για να αποφύγετε τραυματισμούς κατά τη συναρμολόγηση πρέπει να φοράτε γάντια.
- ⚠ Το προϊόν επιτρέπεται να χρησιμοποιείται μόνο σαν μέσο λουτρού, υγιεινής και καθαρισμού του σώματος.
- ⚠ Παιδιά ή ενήλικες με μειωμένες σωματικές, διανοητικές και/ή αισθητήριες ανεπάρκειες δεν επιτρέπεται να χρησιμοποιούν το προϊόν χωρίς επιτήρηση. Άτομα υπό την επήρεια οινοπνεύματος ή ναρκωτικών δεν επιτρέπεται να χρησιμοποιούν σε καμία περίπτωση το προϊόν
- ⚠ Οι διαφορές της πίεσης μεταξύ της σύνδεσης κρύου και ζεστού νερού θα πρέπει να αντισταθμίζονται.

## Οδηγίες συναρμολόγησης

- Η κεντρική βάνα πρέπει να τοποθετηθεί, να πλυθεί και να ελεγχθεί με βάση τους ισχύοντες κανόνες υδραυλικής τέχνης!
- Πριν τη συναρμολόγηση πρέπει να εξεταστεί το προϊόν για ζημιές μεταφοράς. Μετά την εγκατάσταση δεν αναγνωρίζονται ζημιές από τη μεταφορά ή επιφανειακές ζημιές.

## Τεχνικά Χαρακτηριστικά

Λειτουργία πίεσης:	έως 1 MPa
Συνιστώμενη λειτουργία πίεσης:	0,1 - 0,5 MPa
Πίεση ελέγχου:	1,6 MPa
(1 MPa = 10 bar = 147 PSI)	
Θερμοκρασία ζεστού νερού:	έως 80 °C
Συνιστώμενη θερμοκρασία ζεστού νερού:	65 °C
Θερμική απολύμανση:	έως 70 °C / 4 min

Περιλαμβάνει βαλβίδα αντεπιστροφής.

Το προϊόν έχει σχεδιαστεί αποκλειστικά για πόσιμο νερό!

## Περιγραφή συμβόλων



Μην χρησιμοποιείτε σιλικόνη που περιέχει οξικό οξύ!



**Χειρισμός** (βλ. σελίδα 66)



**Καθαρισμός**

βλ. συνημμένο φυλλάδιο

**max. Safety Function** (Λειτουργία ασφαλείας) (βλ. σελίδα 62)

≈ 42 °C

Χάρη στη λειτουργία ασφαλείας Safety Function, είναι δυνατή η προρρυθμισμό της επιθυμητής μέγιστης θερμοκρασίας (π.χ. 42° C).



**Ρύθμιση** (βλ. σελίδα 62)

Αφότου πραγματοποιηθεί η συναρμολόγηση, θα πρέπει να ελεγχθεί η θερμοκρασία του στομίου εκροής του θερμοστάτη. Μία διόρθωση είναι απαραίτητη όταν η μετρούμενη στο σημείο λήψης θερμοκρασία αποκλίνει από τη ρυθμισμένη στο θερμοστάτη θερμοκρασία.



**Συντήρηση** (βλ. σελίδα 64)

- Για να διασφαλίσετε την καλή λειτουργία της μονάδας ρύθμισης, θα πρέπει να ρυθμίζετε το θερμοστάτη από καιρού εις καιρόν σε εντελώς ζεστό ή εντελώς κρύο.
- Ο θερμοστάτης είναι εξοπλισμένος με μία βαλβίδα αντεπιστροφής. Οι βαλβίδες αντεπιστροφής πρέπει να ελέγχονται τακτικά ως προς τη λειτουργία τους, σύμφωνα με το πρότυπο DIN EN 1717, σε σχέση με τους ισχύοντες εθνικούς ή τοπικούς κανόνες (το ελάχιστο μια φορά το χρόνο) .



**Ανταλλακτικά** (βλ. σελίδα 68)

XXX = Χρώματα

000 = Επιχρωμιωμένο

400 = Λευκό/Επιχρωμιωμένο



**Σήμα ελέγχου** (βλ. σελίδα 66)



**Διαστάσεις** (βλ. σελίδα 67)



**Διάγραμμα ροής**  
(βλ. σελίδα 67)





- ① Εξοδος μανιέρας
- ② Εξοδος ντους

<b>Βλάβη</b>	<b>Αιτία</b>	<b>Διόρθωση</b>
Ανεπαρκές νερό	<ul style="list-style-type: none"> <li>- Η πίεση παροχής δεν είναι επαρκής</li> <li>- Βρώμικο φίλτρο συλλογής ακαθαρσιών της μονάδας ρύθμισης</li> <li>- Βρώμικη στεγανοποιητική σήτα του καταιονιστήρα</li> </ul>	<ul style="list-style-type: none"> <li>- Ελέγξτε την πίεση των αγωγών αποχέτευσης/ύδρευσης</li> <li>- Καθαρίστε το φίλτρο συλλογής ακαθαρσιών προ του θερμοστάτη και επάνω στη μονάδα ρύθμισης</li> <li>- Καθαρίστε και, εάν χρειαστεί, αλλάξτε τη στεγανοποιητική σήτα μεταξύ καταιονιστήρα και σπιράλ</li> </ul>
Η σταυροειδής ροή και το ζεστό νερό ρυθμίζονται με κλειστή βάνα στον αγωγό κρύου νερού, πατώντας τη βάνα ή αντίστροφα	<ul style="list-style-type: none"> <li>- Βρώμικη/ελαττωματική βαλβίδα αντεπιστροφής</li> </ul>	<ul style="list-style-type: none"> <li>- Καθαρίστε και, εάν χρειαστεί, αλλάξτε τη βαλβίδα αντεπιστροφής</li> </ul>
Η θερμοκρασία εκροής δεν συμφωνεί με τη ρυθμισμένη θερμοκρασία	<ul style="list-style-type: none"> <li>- Ο θερμοστάτης δεν έχει ρυθμιστεί</li> <li>- Χαμηλή θερμοκρασία ζεστού νερού</li> </ul>	<ul style="list-style-type: none"> <li>- Ρυθμίστε το θερμοστάτη</li> <li>- Αυξήστε τη θερμοκρασία του ζεστού νερού μεταξύ των 42°C και των 65°C</li> </ul>
Δεν είναι δυνατή η ρύθμιση της θερμοκρασίας	<ul style="list-style-type: none"> <li>- Η μονάδα ρύθμισης θερμοκρασίας είναι βρώμικη ή φέρει άλατα</li> <li>- Σε νέα εγκατάσταση: Λάθος σύνδεση βασικού κορμού (θα πρέπει: κρύο δεξιά, ζεστό αριστερά) ή ο βασικός κορμός έχει εγκατασταθεί περιστρεφόμενος κατά 180°</li> </ul>	<ul style="list-style-type: none"> <li>- Καθαρίστε και, εάν χρειαστεί, αλλάξτε τη μονάδα ρύθμισης θερμοκρασίας</li> <li>- Εγκαταστήστε το σώμα λειτουργίας περιστρέφοντάς το κατά 180°</li> </ul>
Πιεστικό κουμπί ή διάταξη φραγής ασφαλείας χωρίς λειτουργία	<ul style="list-style-type: none"> <li>- Ελαττωματικό ελατήριο</li> <li>- Αφαλατωμένο πιεστικό κουμπί</li> </ul>	<ul style="list-style-type: none"> <li>- Καθαρίστε και λιπάνετε ελαφρά, και, εάν χρειαστεί, αλλάξτε το ελατήριο ή/και το πιεστικό κουμπί</li> </ul>
Η λειτουργία του διακόπτη επιλογής είναι δύσκολη	<ul style="list-style-type: none"> <li>- Ελαττωματικό φυσιγγίο</li> </ul>	<ul style="list-style-type: none"> <li>- Αλλαγή φυσιγγίου</li> </ul>
Ο διακόπτης επιλογής δεν έχει στεγανοποιηθεί	<ul style="list-style-type: none"> <li>- Βρωμιά ή καθιζήσεις στο στεγανοποιητικό φίλτράκι</li> </ul>	<ul style="list-style-type: none"> <li>- Καθαρίστε το στεγανοποιητικό φίλτράκι ή το διακόπτη επιλογής</li> </ul>





## **Varnostna opozorila**

-  Pri montaži je treba nositi rokavice, da se preprečijo poškodbe zaradi zmečkanja ali urezov.
-  Ta izdelek se sme uporabljati le z namenom umivanja, vzdrževanja higiene in telesne nege.
-  Otroci kot tudi odrasle osebe z omejenimi telesnimi, duševnimi in/ali senzoričnimi sposobnostmi ne smejo nenadzorovano uporabljati tega izdelka. Osebe, ki so pod vplivom alkohola ali drog, tega izdelka ne smejo uporabljati.
-  Il est conseillé d'équilibrer les pressions de l'eau chaude et froide.

## **Navodila za montažo**

- Armaturo je potrebno montirati, sprati in testirati v skladu z veljavnimi normami!
- Pred montažo je treba izdelek preveriti glede morebitnih transportnih poškodb. Po vgradnji transportne ali površinske poškodbe ne bodo več priznane.

## **Tehnični podatki**

Delovni tlak:	maks. 1 MPa
Priporočeni delovni tlak:	0,1 - 0,5 MPa
Preskusni tlak:	1,6 MPa
(1 MPa = 10 bar = 147 PSI)	
Temperatura tople vode:	maks. 80 °C
Priporočena temperatura tople vode:	65 °C
Termična dezinfekcija:	maks. 70 °C / 4 min

Zaščita proti povratnemu toku

Proizvod je zasnovan izključno za sanitarno vodo!

## **Opis simbola**



Ne smete uporabiti silikona, ki vsebuje ocetno kislino!



### **Upravljanje** (glejte stran 66)



### **Čiščenje**

glejte priloženi brošuri.

**max. Varnostna funkcija** . (glejte stran 62)  
**≈ 42 °C**

Varnostna funkcija omogoča, da vnaprej nastavimo najvišjo želeno temperaturo npr. 42° C.



### **Nastavitev** (glejte stran 62)

Po opravljeni montaži je treba preveriti iztočno temperaturo na termostatu. Če na odvzemnem mestu izmerjena temperatura odstopa od temperature, nastavljene na termostatu, je potreben popravek.



### **Vzdrževanje** (glejte stran 64)

- Da bi zagotovili gladko delovanje enote za uravnavanje, je potrebno termostat občasno nastaviti popolnoma na toplo in popolnoma na mrzlo.
- Termostat je opremljen s protipovratnim ventilom. Delovanje protipovratnega ventila je potrebno v skladu z DIN EN 1717 in skladno z državnimi in regionalnimi določili redno testirati (najmanj enkrat letno).



### **Rezervni deli** (glejte stran 68)

XXX = Barve  
000 = krom  
400 = bela/krom



### **Preskusni znak** (glejte stran 66)



**Mere** (glejte stran 67)



**Diagram pretoka**

(glejte stran 67)

- ① Odvod banje
- ② Odvod prhe

<b>Napaka</b>	<b>Vzrok</b>	<b>Pomoč</b>
Malo vode	<ul style="list-style-type: none"> <li>- Ne zadosten oskrbovalni tlak</li> <li>- Filter enote za uravnavanje je umazan</li> <li>- Filtrirna mrežica prhe je umazana</li> </ul>	<ul style="list-style-type: none"> <li>- Preverite tlak v ceveh</li> <li>- Očistite filtre pred termostatom in na enoti za uravnavanje</li> <li>- Očistite filtrirno mrežico med prho in gibko cevjo</li> </ul>
Križni tok, toplo vodo ob zaprti armaturi potiska v cevi mrzle vode ali obratno	<ul style="list-style-type: none"> <li>- Protipovratni ventil je umazan/pokvarjen</li> </ul>	<ul style="list-style-type: none"> <li>- Očistite oz. po potrebi zamenjajte protipovratni ventil</li> </ul>
Temperatura vode pri izlivu ne ustreza temperaturi, ki ste jo nastavili.	<ul style="list-style-type: none"> <li>- Termostat ni bil justiran</li> <li>- Prenizka temperatura tople vode</li> </ul>	<ul style="list-style-type: none"> <li>- Justirajte termostat</li> <li>- Povišajte temperaturo tople vode na 42 °C do 65 °C</li> </ul>
Uravnavanje temperature ni mogoče	<ul style="list-style-type: none"> <li>- Enota za uravnavanje temperature je umazana ali poapnena</li> <li>- Pri novi inštalaciji je osnovni del napačno priključen (moralo bi biti: mrzlo desno, toplo levo) ali vgrajen z zasukom za 180°.</li> </ul>	<ul style="list-style-type: none"> <li>- Očistite oz. po potrebi zamenjajte enoto za uravnavanje temperature</li> <li>- Vgradite funkcijski blok za 180° obrnjeno</li> </ul>
Gumb varnostne zapore ne deluje	<ul style="list-style-type: none"> <li>- Pokvarjena vzmet</li> <li>- Gumb je poapnen</li> </ul>	<ul style="list-style-type: none"> <li>- Očistite in rahlo namastite oz. po potrebi zamenjajte vzmet oz. gumb</li> </ul>
Preklapljanje preklopnika je težko	<ul style="list-style-type: none"> <li>- Pokvarjen vložek</li> </ul>	<ul style="list-style-type: none"> <li>- Zamenjajte vložek</li> </ul>
Preklopnik ne tesni	<ul style="list-style-type: none"> <li>- Umazanija ali usedline na nasedu tesnila</li> </ul>	<ul style="list-style-type: none"> <li>- Očistite sedež ventila ali zamenjajte preklopnik</li> </ul>



**Montaža** Glejte stran 60.



## Ohutusjuhised

- △ Kandke paigaldamisel muljumis- ja löikevigastuste vältimiseks kindaid.
- △ Toodet tohib kasutada ainult pesemis-, hügieeni- ja kehapihustamiseesmärkidel.
- △ Lapsed, samuti kehaliste, vaimsete või tajupiirangutega täiskasvanud ei tohi dušisüsteemi järelvalveta kasutada. Alkoholi või narkootikumide mõju all olevad isikud ei tohi dušisüsteemi kasutada.
- △ Kui külma ja kuuma vee ühenduste surve on väga erinev, tuleb need tasakaalustada.

## Paigaldamisjuhised

- Segisti paigaldamine, loputamine ja kontroll peab toimuma vastavalt kehtivatele normidele!
- Enne paigaldamist tuleb toodet kontrollida transpordikahjustuste osas. Pärast paigaldamist ei tunnustata enam transpordi- või pinnakahjustuste kaebuseid.

## Tehnilised andmed

Töörõhk	maks. 1 MPa
Soovitatav töörõhk:	0,1 - 0,5 MPa
Kontrollsurve:	1,6 MPa
(1 MPa = 10 baari = 147 PSI)	
Kuuma vee temperatuur:	maks. 80 °C
Soovitatav kuuma vee temperatuur:	65 °C
Termiline desinfitatsioon:	maks. 70 °C / 4 min

Tagasivooluklapp

Toode on ette nähtud eranditult joogivee jaoks!

## max. Turvafunktsioon (vt lk 62)

≈ 42 °C

Tänu ohutusfunktsioonile on võimalik soovitud maksimaaltemperatuuri eelnevalt sisestada (nt maks. 42 °C).



## Reguleerimine (vt lk 62)

Paigaldamise järel tuleb kontrollida termostaadi väljundtemperatuuri. Kui väljavoolu kohas mõõdetud temperatuur erineb termostaadiga sisestatust, tuleb seda reguleerida.



## Hooldus (vt lk 64)

- Termostaadi hea toimimise tagamiseks on tarvis termostaat keerata aeg-ajalt päris kuuma ja päris külma peale.
- Termostaat on varustatud tagasilöögiklappidega. Tagasilöögiklappide toimimist tuleb kooskõlas riiklike ja regionaalsete määrustega regulaarselt kontrollida vastavalt standardile DIN EN 1717 (vähemalt kord aastas).



## Varuosad (vt lk 68)

XXX = Värvikood  
000 = kroom  
400 = valge/kroom

## Sümbolite kirjeldus



Ärge kasutage äädikhapet sisaldavat silikooni!



**Kasutamine** (vt lk 66)



**Puhastamine**

vt kaasasolevast brošüürist.



## Kontrollsertifikaat (vt lk 66)



## Mõõtude (vt lk 67)



## Läbivooludiagramm

(vt lk 67)

- ① Vanni väljund
- ② Duši väljund

Rike	Põhjus	Lahendus
Vähe vett	- Surve ebapiisav	- Kontrollige vee survet torudes (kui pump on installeeritud, kontrollige kas pump töötab)
	- Regulaatori filter on määrdunud	- Puhastage termostaadi ees ja regulaatori peal olevad filtrid
	- Duši sõelühend must	- Puhastage duši ja vooliku vaheline sõelühend
Ristvool, soe vesi surutakse suletud segisti korral külmaveetoru või vastupidi, kui segisti on suletud	- Tagasilöögiklapp määrdunud/katki	- Tagasilöögiklapp puhastada ja vajadusel välja vahetada
Väljavoolava vee temperatuur ei vasta seatud temperatuurile	- Termostaati pole reguleeritud	- Reguleerige termostaati
	- Sooja vee temperatuur liiga madal	- Tõstke sooja vee temperatuuri 42 °C kuni 65 °C
Termoregulatsioon pole võimalik	- Termoregulaator määrdunud või lupjunud	- Termoregulaator puhastada või vajadusel välja vahetada
	- Uuel paigaldusel põhikorpus valesti ühendatud (peab olema külm paremal, soe vasakul) või 180° pööratud	- Paigaldage funktsiooniblokk 180° pöördega
Ohutusnupp ei tööta	- Vedru on vigastatud või veaga	- Puhastage ning määrige kergelt vedru või nuppu, vajadusel vahetage ära
	- Gumb ja poapnen	
Ümberlüüti käib raskelt	- Tööelement on katkine	- Vahetage tööelement
Ümberlüüti lekib	- Mustus või ladestused tihendil	- Puhastage tihend või pange uus ümberlüüti





## Drošības norādes

- △ Montāžas laikā, lai izvairītos no saspiedumiem un iegriezumiem, nepieciešams nēsāt cimdus.
- △ Šo produktu drīkst izmantot tikai, lai mazgātos, higiēnai un ķermeņa tīrīšanai.
- △ Bērni, kā arī pieaugušie ar fiziskiem, garīgiem un / vai sensoriskiem ierobežojumiem nedrīkst lietot šo produktu bez uzraudzības. Personas, kas atrodas alkohola vai narkotisko vielu iespaidā, nedrīkst lietot šo dušas sistēmu.
- △ Jāizlīdzina spiediena atšķirības starp aukstā un karstā ūdens pievadiem.

## Norādījumi montāžai

- Armatūra jāuzstāda, jāizskalo un jāpārbauda atbilstoši spēkā esošajām normām!
- Pirms montāžas nepieciešams pārbaudīt, vai produktam transportēšanas laikā nav radušies bojājumi. Pēc iebūvēšanas bojājumi, kas radušies transportēšanas laikā, vai virsmas bojājumi netiek atzīti.

## Tehniskie dati

Darba spiediens:	maks. 1 MPa
leteicamais darba spiediens:	0,1 - 0,5 MPa
Pārbaudes spiediens:	1,6 MPa
(1 MPa = 10 bar = 147 PSI)	
Karstā ūdens temperatūra:	maks. 80 °C
leteicamā karstā ūdens temperatūra:	65 °C
Termiskā dezinfekcija :	maks. 70 °C / 4 min

Drošības vārsts

Izstrādājums ir paredzēts tikai dzeramajam ūdenim!

## Simbolu nozīme



Neizmantot silikonu, kas satur etiķskābi!



**Lietošana** (skat. 66. lpp.)



**Tīrīšana**

skatiet pievienotajā brošūrā.

**max. Drošības funkcija** (skat. 62. lpp.)  
≈ 42 °C

Pateicoties drošības funkcijai, vēlamo augstāko temperatūru, piem., maks. 42 °C, var iestatīt jau iepriekš.



**Ieregulēšana** (skat. 62. lpp.)

Pēc montāžas jāpārbauda termostata iztekas temperatūra. Korektūra ir nepieciešama gadījumā, ja temperatūra iztekas vietā atšķiras no termostatā iestatītās temperatūras.



**Apkope** (skat. 64. lpp.)

- Lai nodrošinātu regulatora nevainojamu darbību, termostatu laiku pa laikam jāiestata uz maksimāli aukstu un maksimāli karstu ūdeni.
- Termostats ir aprīkots ar pretvārstu. Regulāri jāpārbauda pretvārsta funkcija saskaņā ar DIN EN 1717 saistībā ar nacionālajiem vai vietējiem noteikumiem (vismaz vienreiz gadā).



**Rezerves daļas** (skat. 68. lpp.)

XXX = Krāsas  
000 = hroma  
400 = balta/hroma



**Pārbaudes zīme** (skat. 66. lpp.)





**Izmērus** (skat. 67. lpp.)



**Caurplūdes diagramma**  
(skat. 67. lpp.)

- ① Vannas izeja
- ② Dušas izeja

<b>Traucējums</b>	<b>Iemesls</b>	<b>Bojājumu novēršana</b>
Maz ūdens	<ul style="list-style-type: none"> <li>- Problēmas ar ūdens apgādi</li> <li>- Nefīrs regulatora filtrs</li> <li>- Nefīrs dušas filtra blīvējums</li> </ul>	<ul style="list-style-type: none"> <li>- Pārbaudīt spiedienu ūdenvadā</li> <li>- Tīrīt filtrus pirms termostata un uz regulatora</li> <li>- Iztīrīt filtra blīvējumu starp dušu un šūteni</li> </ul>
Ūdens sajaukšanās, karstais ūdens slēgtā stāvoklī tiek spiests aukstā ūdens cauruļvados un otrādi.	<ul style="list-style-type: none"> <li>- Pretvārsts ir nefīrs / bojāts</li> </ul>	<ul style="list-style-type: none"> <li>- Tīrīt, nepieciešamības gad. nomainīt pretvārstu</li> </ul>
Ūdens temperatūra nesaskan ar iestatīto temperatūru	<ul style="list-style-type: none"> <li>- Termostats nav pieregulēts</li> <li>- Pārāk zema ūdens temperatūra</li> </ul>	<ul style="list-style-type: none"> <li>- Pieregulēt termostatu</li> <li>- Paaugstināt karstā ūdens temperatūru no 42 °C līdz 65 °C</li> </ul>
Nav iespējama temperatūras regulēšana	<ul style="list-style-type: none"> <li>- Termoregulators ir aizkalķojies vai nefīrs</li> <li>- Jaunas instalācijas gadījumā pamatelements ir nepareizi pieslēgts (jābūt: aukstais ūdens pa labi, karstais pa kreisi) vai ir pārgriezts par 180°.</li> </ul>	<ul style="list-style-type: none"> <li>- Iztīrīt, nepieciešamības gad. nomainīt termoregulatoru</li> <li>- Pagrieziet par 180° iekšējo bloku</li> </ul>
Nestrādā sarkanā poga, kas pasargā pret apdedzināšanos	<ul style="list-style-type: none"> <li>- Bojāta atspere</li> <li>- Poga ir aizkalķojusies</li> </ul>	<ul style="list-style-type: none"> <li>- Iztīrīt un ieeļļot, ja nepieciešams, nomainīt atspere vai pogu</li> </ul>
Pārslēdzējs grūti pārslēdzams	<ul style="list-style-type: none"> <li>- Bojāta kartuša</li> </ul>	<ul style="list-style-type: none"> <li>- Nomainīt kartušu</li> </ul>
Pārslēdzējs nav blīvs	<ul style="list-style-type: none"> <li>- Nefīrumi vai nogulsnes uz blīvvirsmas</li> </ul>	<ul style="list-style-type: none"> <li>- Notīrīt blīvvirsmu vai nomainīt pārslēdzēju</li> </ul>





## Sigurnosne napomene

- △ Prilikom montaže se radi sprečavanja prignječenja i posekotina moraju nositi rukavice.
- △ Proizvod sme da se koristi samo za kupanje, tuširanje i ličnu higijenu.
- △ Deca, kao i telesno, mentalno i/ili senzorno hendikepirane odrasle osobe ne smeju da koriste proizvod bez nadzora. Osobe koje su pod uticajem alkohola ili droga ne smeju da koriste proizvod.
- △ Velika razlika u pritisku između vruće i hladne vode mora biti izbalansirana.

## Instrukcije za montažu

- Armatura mora biti postavljena, isprana i testirana prema važećim normama!
- Pre montaže se mora proveriti da li je proizvod oštećen pri transportu. Nakon ugradnje se ne priznaju nikakve reklamacije koje se odnose na površinska i transportna oštećenja.

## Tehnički podaci

Radni pritisak:	maks. 1 MPa
Preporučeni radni pritisak:	0,1 - 0,5 MPa
Probni pritisak:	1,6 MPa
(1 MPa = 10 bar = 147 PSI)	
Temperatura vruće vode:	maks. 80°C
Preporučena temperatura vruće vode:	65°C
Termička dezinfekcija:	maks. 70°C / 4 min

Zaštita od povratnog toka

Proizvod je koncipiran isključivo za pijaću vodu!

## Opis simbola



Nemojte koristiti silikon koji sadrži sirćetnu kiselinu!



### Rukovanje (vidi stranu 66)



### Čišćenje

vidi priloženoj brošuri.

**max. Safety funkcija (vidi stranu 62)**  
**≈ 42°C**

Zahvaljujući Safety funkciji, može se podesiti željena maksimalna temperatura, npr. maks. 42°C.



### Podešavanje (vidi stranu 62)

Nakon instalacije potrebno je ispitati izlaznu temperaturu termostata. Korekcija je neophodna, ako izmerena temperatura odstupa od temperature koja je nameštena na termostatu.



### Održavanje (vidi stranu 64)

- Kako bi se olakšala prohodnost i produžio vek trajanja regulacione jedinice, potrebno je s vremena na vreme podesiti termostat na položaje za maksimalno toplu i maksimalno hladnu vodu.
- Termostat je opremljen nepovratnim ventilom. Ispravno funkcionisanje nepovratnog ventila se mora redovno proveravati prema standardu DIN EN 1717 i u skladu s važećim nacionalnim ili regionalnim propisima (najmanje jednom godišnje).



### Rezervni delovi (vidi stranu 68)

XXX = Oznake boja  
000 = hrom  
400 = bela/hrom



### Ispitni znak (vidi stranu 66)



**Mere** (vidi stranu 67)



**Dijagram protoka**  
(vidi stranu 67)

- ① Ogranak kada
- ② Ogranak tuš





<b>Smetnja</b>	<b>Uzrok</b>	<b>Pomoć</b>
Nedovoljno vode	<ul style="list-style-type: none"> <li>- Prenizak pritisak vode</li> <li>- Očistite mrežicu za hvatanje prljavštine regulacione jedinice</li> <li>- Mrežasta zaptivka tuša je prljava</li> </ul>	<ul style="list-style-type: none"> <li>- Ispitajte pritisak u cevima</li> <li>- Očistite mrežice za hvatanje prljavštine ispred termostata i na regulacionoj jedinici</li> <li>- Očistite mrežastu zaptivku između tuša i crijeva</li> </ul>
Ukršteni tok vode, kod zatvorene armature vruća voda ulazi u cev s hladnom vodom i obrnuto	<ul style="list-style-type: none"> <li>- Nepovratni ventil je prljav / neispravan</li> </ul>	<ul style="list-style-type: none"> <li>- Očistite ili, po potrebi, zamenite nepovratni ventil</li> </ul>
Temperatura na slavini se ne podudara s podešenom temperaturom	<ul style="list-style-type: none"> <li>- Termostat nije podešen</li> <li>- Preniska temperatura tople vode</li> </ul>	<ul style="list-style-type: none"> <li>- Podesite termostat</li> <li>- Povećajte temperaturu vruće vode na 42-65 °C</li> </ul>
Regulisanje temperature nije moguće	<ul style="list-style-type: none"> <li>- Regulator temperature je prljav ili obložen naslagama kamenca</li> <li>- Pri ponovnoj instalaciji telo je pogrešno priključeno (potrebno je priključiti hladnu vodu desno, a vruću levo) ili je zakrenuto za 180 stepeni.</li> </ul>	<ul style="list-style-type: none"> <li>- Očistite ili zamenite regulator temperature.</li> <li>- Unutrašnji blok okrenite za 180 stepeni</li> </ul>
Dugme sigurnosnog prekida je van funkcije	<ul style="list-style-type: none"> <li>- Opruga je neispravna</li> <li>- Dugme je začepljeno slojem kamenca</li> </ul>	<ul style="list-style-type: none"> <li>- Očistite i podmažite oprugu, tj. dugme, u slučaju potrebe dugme možete zameniti novim</li> </ul>
Preusmerivač se teško pomera	<ul style="list-style-type: none"> <li>- Neispravna kartuša</li> </ul>	<ul style="list-style-type: none"> <li>- Zamenite kartušu</li> </ul>
Preusmerivač ne zaptiva	<ul style="list-style-type: none"> <li>- Prljavština ili naslage kamenca na zaptivnim sedalima</li> </ul>	<ul style="list-style-type: none"> <li>- Očistite zaptivna sedala ili zamenite preusmerivač</li> </ul>



**Montaža vidi stranu 60**



## Sikkerhetshenvisninger

-  Bruk hansker under montasjen for å unngå klem- og kuttskader.
-  Dusjsystemet skal kun brukes for bade-, hygiene- og kroppshygiene.
-  Barn og voksne med fysiske og psykiske og/eller sensoriske handicap skal ikke bruke dusjsystemet uten oppsyn. Personer som er påvirket av alkohol eller narkotika skal ikke bruke dusjsystemet.
-  Store trykkdifferanser mellom kaldt- og varmtvannstilkoblinger skal utlignes.

## Montagehenvisninger

- Armaturen skal monteres iht. gyldige standarder. De skal spyles og sjekkes!
- Før montasjen skal produktet sjekkes for transportskader. Etter monteringen aksepteres ikke noen transport- eller overflateskader.

## Tekniske data

Driftstrykk	maks. 1 MPa
Anbefalt driftstrykk:	0,1 - 0,5 MPa
Prøvetrykk	1,6 MPa
(1 MPa = 10 bar = 147 PSI)	
Varmtvannstemperatur	maks. 80 °C
Anbefalt temperatur for varmt vann	65 °C
Termisk desinfisering:	maks. 70 °C / 4 min

Egensikker mot tilbakeflyt

Produktet er utelukkende designet for drikkevann!

## Symbolbeskrivelse



Ikke bruk silikon som inneholder eddiksyre!



**Betjening** (se side 66)



**Rengjøring**

se vedlagt brosjyre.

**max. Safety Function** (se side 62)

≈ 42 °C

Takket være egenskapen "Safety Function" kan det forhåndsinnstilles en ønsket maks. temperatur, f.eks. 42 °C.



**Justering** (se side 62)

Etter avsluttet montering skal termostatens utløpstemperatur kontrolleres. Det er nødvendig med korrektur når temperaturen målt ved uttaksstedet avviker fra temperaturen som er innstilt på termostaten.



**Vedlikehold** (se side 64)

- For å holde regulerings-enheten bevegelig, skal termostaten stilles fra tid til annen på helt varmt og helt kaldt.
- Termostaten er utstyrt med returløpssperre. Funksjonen til returløpssperren skal iht. DIN EN 1717 og i samsvar med de nasjonale og lokale forskrifter sjekkes regelmessig (DIN 1988 en gang i året).



**Serviceledere** (se side 68)

XXX = Oznake boja

000 = hrom

400 = bela/hrom



**Prøvemerket** (se side 66)



**Mål** (se side 67)



**Gjennomstrømningsdiagram**  
(se side 67)

- ① Utgang kar
- ② Utgang dusj





Feil	Årsak	Feilrettelse
Lite vann	<ul style="list-style-type: none"> <li>- Forsyningstrykk er ikke tilstrekkelig</li> <li>- Smussfangersil til reguleringsenheten skitten.</li> <li>- Dusjens silpakning er skitten</li> </ul>	<ul style="list-style-type: none"> <li>- Ledningstrykk sjekkes</li> <li>- Smussfangersil før termostaten og på reguleringsenheten rengjøres</li> <li>- Silpakning mellom dusj og slangen rengjøres</li> </ul>
Krysstrømning, varmt vann presses ved lukket armatur inn i kaldvannsledning eller omvendt	<ul style="list-style-type: none"> <li>- Returløpstopper skitten / defekt</li> </ul>	<ul style="list-style-type: none"> <li>- Returløpstopper rengjøres, byttes hvis nødvendig</li> </ul>
Utløpstemperatur samsvarer ikke med innstilt temperatur	<ul style="list-style-type: none"> <li>- Termostat ble ikke justert</li> <li>- For lav varmtvannstemperatur</li> </ul>	<ul style="list-style-type: none"> <li>- Termostat justeres</li> <li>- Varmtvannstemperatur økes til mellom 42 °C og 65 °C</li> </ul>
Temperaturregulering er ikke mulig	<ul style="list-style-type: none"> <li>- Reguleringsenhet for temperatur er skitten eller forkalket</li> <li>- Ved nyinstallasjon: basiselement feilaktig tilkoblet (riktig: kaldt høyre, varmt venstre) eller bygd inn 180° forvrent</li> </ul>	<ul style="list-style-type: none"> <li>- Reguleringsenhet for temperatur rengjøres og byttes hvis nødvendig</li> <li>- Funksjonsblokk bygges inn 180° forvrent</li> </ul>
Trykknapp til sikkerhetssperreren uten funksjon	<ul style="list-style-type: none"> <li>- Fjær defekt</li> <li>- Kalk på trykknapp</li> </ul>	<ul style="list-style-type: none"> <li>- Fjær hhv. Trykknapp rengjøres og smøres lett inn, byttes hvis nødvendig</li> </ul>
Omstiller er ikke lett bevegelig	<ul style="list-style-type: none"> <li>- Kartusj defekt</li> </ul>	<ul style="list-style-type: none"> <li>- Kartusj byttes</li> </ul>
Omstiller er utett	<ul style="list-style-type: none"> <li>- Smuss eller avleiringer på tetningen</li> </ul>	<ul style="list-style-type: none"> <li>- Tetning rengjøres eller omstiller byttes</li> </ul>



**Montasje se side 60**



## **Указания за безопасност**

-  При монтажа трябва да се носят ръкавици, за да се избегнат наранявания поради притискане или порязване.
-  Позволено е използването на продукта само за къпане, хигиена и цели на почистване на тялото.
-  Не е позволено деца, както и възрастни с физически, умствени и / или сензорни ограничения да използват продукта без надзор. Не е позволено използването на системата на продукта от лица, употребили алкохол или дрога.
-  Големите разлики в налягането между изводите за студената и топлата вода трябва да се изравняват.

## **Указания за монтаж**

- Арматурата трябва да се монтира, промие и провери в съответствие с валидните норми!
- Преди монтажа продуктът трябва да се провери за транспортни щети. След монтажа не се признават транспортни или повърхностни щети.

## **Технически данни**

Работно налягане: макс. 1 МПа  
 Препоръчително работно налягане: 0,1 - 0,5 МПа  
 Контролно налягане: 1,6 МПа  
 (1 МПа = 10 bar = 147 PSI)  
 Температура на горещата вода: макс. 80 °C  
 Препоръчителна температура на горещата вода: 65 °C  
 Термична дезинфекция: макс. 70 °C / 4 мин

Самозащитен против обратно изтичане  
 Продуктът е разработен само за питейна вода!

## **Описание на символите**



Не използвайте силикон, съдържащ оцетна киселина!



**Обслужване** (вижте стр. 66)



**Почистване**

от приложената брошура.

**max. Safety Function** (Функция за безопасност) (вижте стр. 62)  
 ≈ 42 °C

Благодарение на Safety Function (функция за безопасност) желаната максимална температура може да се настрои предварително напр. на макс. 42 °C.



**Юстиране** (вижте стр. 62)

След извършен монтаж трябва да се провери температурата на крайника на термостата. Ако измерената температура на мястото на водоземане се различава от настроената на термостата температура, е необходима корекция.



**Поддръжка** (вижте стр. 64)

- За да се гарантира лекоподвижността на регулиращото звено, от време на време термостатът трябва да се поставя на максимално топло и на максимално студено.
- Термостатът е оборудван с предпазител за обратен поток. Съгласно DIN EN 1717 функционирането на приспособленията за предотвратяване на обратния поток трябва редовно да се проверява в съответствие с националните или регионални изисквания (поне веднъж годишно).



**Сервизни части** (вижте стр. 68)

XXX = Ozname boja  
 000 = hrom  
 400 = bela/hrom



**Контролен знак** (вижте стр. 66)



**Размери** (вижте стр. 67)



**Диаграма на потока**  
(вижте стр. 67)

- ① Извод вана
- ② Изход разпръсквател

Неизправност	Причина	Помощ
Малко вода	- Захранващото налягане не е достатъчно	- Проверете налягането на тръбопровода
	- Цедката за улавяне на замърсяванията на регулиращия елемент е замърсена	- Почистете цедките за улавяне на замърсяванията преди термостата и на регулиращия елемент
	- Замърсено е уплътнението с цедка на разпръсквателя	- Почистете уплътнението с цедка между разпръсквателя и маркуча
Кръстосване на потока, при затворена арматура топлата вода навлиза в линията на студената вода или обратно	- Замърсено / дефектно приспособление за предотвратяване на обратния поток	- Почистете респ. сменете приспособлението за предотвратяване на обратния поток
Изходящата температура не съпада с настроената температура	- Термостатът не е юстиран	- Юстиране на термостата
	- Твърде ниска температура на водата	- Повишете ограничението за топлата вода на 42 °C до 65 °C
Не е възможно регулиране на температурата	- Приспособлението за регулиране на температурата е замърсено или покрито с варовик	- Почистете респ. сменете приспособлението за регулиране на температурата
	- При нова инсталация основното тяло е свързано погрешно (Зад.: студено отдясно, топло отляво или монтирайте със завъртане от 180°	- Монтирайте функционалния блок със завъртане на 180°
Копчето на предпазната блокировка не функционира	- Дефектна пружина	- Почистете пружината респ. копчето и ги смажете леко, при необх. ги сменете
	- Копчето е покрито с варовик	
Трудно подвижен превключвател	- Дефектна гилза	- Сменете гилзата
Не херметичен превключвател	- Мръсотия или отлагания на уплътняващата повърхност	- Почистете уплътняващата повърхност или сменете превключвателя



**Монтаж вижте стр. 60**



## Udhëzime sigurie

- △ Për të evituar lëndimet e pickimeve ose të prerjeve gjatë procesit të montimit duhet që të vishni doreza.
- △ Produkti duhet të përdoret vetëm qëllimet e banjave, të higjienës dhe të larjes së trupit.
- △ Fëmijët dhe të rriturit me aftësi të kufizuara fizike, mendore dhe/ose ndijuese nuk duhet ta përdorin produktin pa qenë nën mbikëqyrje. Personat që janë nën ndikimin e drogave ose të alkoolit nuk duhet ta përdorin produktin.
- △ Ndryshimet e mëdha të presionit mes lidhjeve të ujit të ftohtë dhe atij të ngrohtë duhen ekuilibruar.

## Udhëzime për montimin

- Armatura duhet montuar, shpërlarë dhe kontrolluar në bazë të normave të vlefshme!
- Përpara montimit duhet që produkti të kontrollohet për dëmtime nga transporti. Pas instalimit nuk do të njihet asnjë dëmtim nga transporti ose dëmtim i sipërfaqes.

## Të dhëna teknike

Presioni gjatë punës	maks. 1 MPa
Presioni i rekomanduar:	0,1 - 0,5 MPa
Presioni për provë:	1,6 MPa
(1 MPa = 10 bar = 147 PSI)	
Temperatura e ujit të ngrohtë	maks. 80 °C
Temperatura e rekomanduar e ujit të ngrohtë:	65 °C
Dezinfektim Termik:	maks. 70 °C / 4 min

Siguresa kundër rrjedhjes në drejtim të kundërt

Produkti është projektuar ekskluzivisht për ujë të pijshëm!

**max. Funkcionet e sigurisë** (shih faqen ≈ 42 °C 62)

Falë Safety Function mund të përcaktohet temperatura maksimale e dëshiruar, p.sh. 42 °C.



## Justimi (shih faqen 62)

Pas montimit duhet kontrolluar temperatura në dalje e termostatit. Korigjimet janë të nevojshme, nëse temperatura e matur në pikën e rrjedhjes së ujit nuk është e njëjtë me temperaturën e përcaktuar në termostat.



## Mirëmbajtja (shih faqen 64)

- Për të lehtësuar përdorimin e njësisë rregulluese, termostati do të duhej çuar herë pas here nga shumë i ngrohtë në shumë të ftohtë.
- Termostati është i pajisur me pengues të rrjedhjes në drejtim të kundërt. Penguesit e rrjedhjes në drejtim të kundërt duhen kontrolluar rregullisht në bazë të normave DIN EN 1717 konform normave nacionale dhe regjionale (së paku një herë në vit).



## Pjesë ndërrimi (shih faqen 68)

XXX = Oznake boja  
000 = hrom  
400 = bela/hrom

## Përshkrimi i simbolit



Mos përdorni silikon që në përbërje ka acid acetik.



## Përdorimi (shih faqen 66)



## Pastrimi

shikoni broshurën bashkëngjitur.



## Shenja e kontrollit (shih faqen 66)





## Përmasat (shih faqen 67)



## Diagrami i qarkullimit (shih faqen 67)

- ① Dalja e vaskës
- ② Dalja e spërkatëses

Dëmtim	Shkaku	Ndihme
Pak ujë	<ul style="list-style-type: none"> <li>- Presioni ushqyes jo limjaftueshem</li> <li>- Sita që mbledh papastertite tek njesia rregulluese është me papasterti</li> <li>- Gomina hermetizuese e pajisjes me papasterti</li> </ul>	<ul style="list-style-type: none"> <li>- Kontrolloni presionin e tubacionit</li> <li>- Pastroni siten para termostatit dhe mbi njesine rregulluese</li> <li>- Pastroni gominen e sites midis pajisjes dhe tubit</li> </ul>
Rrjedhje e kryqezuar, uji i ngrohte do të cohet tek tubacioni i ujit të ftohte kur armatura është e mbyllur ose anasjelltas	<ul style="list-style-type: none"> <li>- Penguesi i rrjedhjes mbrapsht te ujit me papasterti ose me defekt</li> </ul>	<ul style="list-style-type: none"> <li>- Pastroni ose kembeni penguesinn e rrjedhjes mbrapsht te ujit</li> </ul>
Temperatura reale nuk përputhet me temperaturën e regjistruar	<ul style="list-style-type: none"> <li>- Termostati nuk është rregulluar</li> <li>- Temperaturë e ulët e ujit të ngrohtë</li> </ul>	<ul style="list-style-type: none"> <li>- Rregulloni termostatin</li> <li>- Risni temperaturën e ujit të ngrohte nga 42 °C deri 65 °C</li> </ul>
Rregullimi i temperaturës nuk është i mundur	<ul style="list-style-type: none"> <li>- Njesia rregulluese e temperaturës me papasterti ose me kalk</li> <li>- Tek instalimi i ri karkasa baze është lidhur gabim(Duhet: ftohte djathtas, ngrohte majtas) ose është montuar 180grade ndryshe</li> </ul>	<ul style="list-style-type: none"> <li>- Pastroni ose kembeni njesine rregulluese te temperaturës</li> <li>- Montoni bllokun e funksioneve ne 180 grade mbrapsht</li> </ul>
Butoni i bllokuesit të sigurisë pa funksion	<ul style="list-style-type: none"> <li>- Susta me defekt</li> <li>- Butoni me kalk</li> </ul>	<ul style="list-style-type: none"> <li>- Pastroni butonin ose susten dhe grasatojeni pak, ose nderrojeni</li> </ul>
Kalibruesi punon rende	<ul style="list-style-type: none"> <li>- Kartusha me defekt</li> </ul>	<ul style="list-style-type: none"> <li>- Kembeni kartushen</li> </ul>
Kalibruesi pa hermetizim	<ul style="list-style-type: none"> <li>- Papastërtira ose depozitime shtupë</li> </ul>	<ul style="list-style-type: none"> <li>- Pastroni pjesen hermetike ose kembeni kalibruesin</li> </ul>





أبعاد (راجع صفحة 67)



رسم للصرف  
(راجع صفحة 67)



- ① صرف البانيو  
② صرف الرشاش

العطل	السبب	العلاج والإصلاح
الماء غير كافٍ	- ضغط الإمداد ليس كافيًا	- افحص ضغط المواسير
	- مرشح الاتساخات الخاص بالمنظم متسخ	- نظف مرشحات الاتساخات إلى الترموستات والمنظم
	- سدادة مصفاة الدش متسخة	- نظف سدادة المصفاة بين الدش والخرطوم
تدفق منعكس للمياه! الماء الساخن يندفع في ماسورة البارد أو العكس والخلاط مغلق.	- صمام منع الرجوع متسخ / تالف	- قم بتنظيف صمام منع الرجوع أو تغييره إذا لزم الأمر
حرارة المياه لا تتوافق مع درجة الحرارة المضبوطة	- لم يتم ضبط الترموستات	- اضبط الترموستات
	- درجة حرارة الماء الساخن منخفضة للالغاية	- ارفع حد الماء الساخن إلى $42^\circ$ - $65^\circ$ درجة مئوية
تنظيم الحرارة غير ممكن	- منظم الحرارة متسخ أو عليه جير	- قم بتنظيف منظم الحرارة أو تغييره إذا لزم الأمر
	- تم تركيب الجزء الرئيسي من الخلاط بشكل خاطيء (ينبغي أن يكون البارد ميمتًا، والساخن يسارًا) أو تم عكسه 180 درجة	- قم بتركيب الكتلة بالعكس 180 درجة
زر الضغط الخاص بقفل الأمان لا يعمل	- الياء تالف - هناك جير على زر الضغط	- قم بتنظيف الياء أو زر الضغط مع تشحيمهما بشكل خفيف. أو قم بتغييرهما إذا لزم الأمر
المحول ثقيل الحركة	- الخرطوشة تالفة	- قم بتغيير الخرطوشة
المحول غير محكم	- اتساخات أو ترسبات على جزء الإحكام	- قم بتنظيف القلب أو تغيير المحول





max.  
≈ 42°C

## وظيفة الأمان (راجع صفحة 62)

يمكن إجراء ضبط مسبق للحد الأقصى لدرجة الحرارة المرغوبة. على سبيل المثال بحد أقصى 42° بفضل وظيفة الأمان.

## ⚠ تنبيهات الأمان

⚠ يجب إرتداء قفازات لليد أثناء التركيب لتجنب حدوث أخطار الانحشار أو الجروح.

⚠ لا يجب استخدام نظام الدش إلا في أغراض الاستحمام والأغراض الصحية وأغراض تنظيف الجسم.

⚠ لا يسمح لأي أطفال أو أفراد بالغين يعانون من إعاقات بدنية أو ذهنية أو حسية أو يعانون من جميع هذه الإعاقات باستخدام المنتج إلا تحت إشراف آخرين. كما أنه لا يسمح لأي شخص تحت تأثير تناول الكحول أو المخدرات باستخدام نظام الدش.

⚠ يجب أن يكون تيار الماء الساخن والماء البارد متعادلين في الضغط.

## تعليمات التركيب

• يجب تركيب الوصلة. وغمرها بالماء واختبارها وفقاً للمعايير السارية!

• قبل القيام بعملية التركيب. يجب فحص المنتج للتأكد من خلوه من أية تلفيات ناجمة عن النقل. بعد القيام بعملية التركيب. لن يتم الاعتراف بوجود أية تلفيات سطحية أو تلفيات ناجمة عن عملية النقل.

## المواصفات الفنية

ضغط التشغيل: الحد الأقصى 1 ميجاباسكال

ضغط التشغيل الموصى به: 0,5 - 0,1 ميجاباسكال

ضغط الاختبار: (1 ميجاباسكال = 10 بار = 147 PSI)

درجة حرارة الماء الساخن: الحد الأقصى 80°C

درجة الحرارة الموصى بها للماء الساخن: 65°C

تعقيم حراري: الحد الأقصى 70°C / 4 الدقيقة

خاصية عدم التدفق العكسي

المنتج مخصص فقط لماء الشرب!

## الضبط (راجع صفحة 62)

بعد التركيب يجب فحص درجة حرارة الترموستات. يلزم إجراء تصحيح إذا اختلفت درجة الحرارة المقاسة عند موقع القياس عن درجة حرارة الترموستات.



## الصيانة (راجع صفحة 64)

• لضمان التشغيل السلس للترموستات. من الضروري تحويله من وقت إلى آخر من أقصى السخونة إلى أقصى البرودة.

• الخلط مزود بصمامات عدم الرجوع يجب فحص صمام عدم الرجوع بصفة منتظمة حسب المواصفة DIN EN 1717 وذلك طبقاً للوائح الوطنية أو الإقليمية (مرة واحد سنوياً على الأقل).

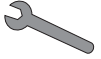

## قطع الغيار (راجع صفحة 68)

XXX = الألوان

000 = كروم

400 = أبيض/كروم



## شهادة اختبار (راجع صفحة 66)



## وصف الرمز

هام! لا تستخدم السليكون الذي يحتوي على أحماض!



## التشغيل (راجع صفحة 66)



## التنظيف

راجع والكتيب المرفق



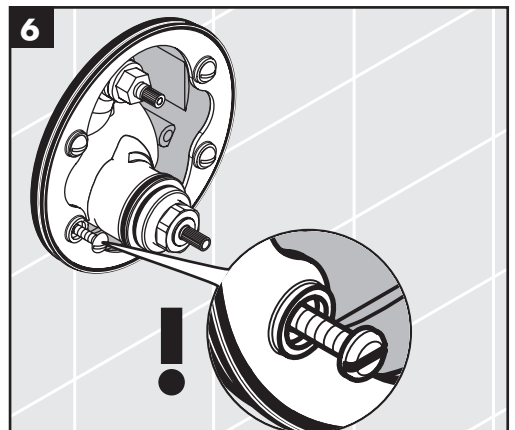
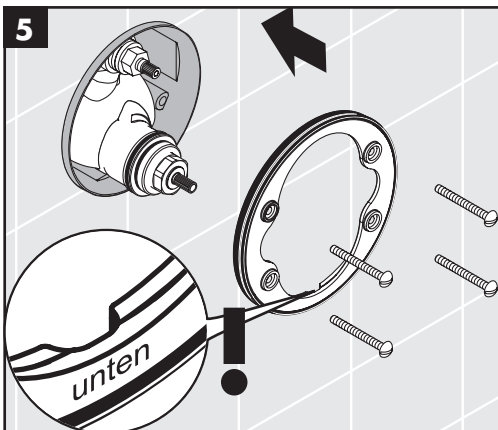
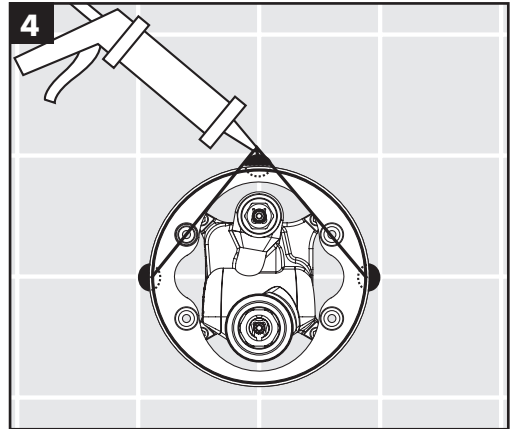
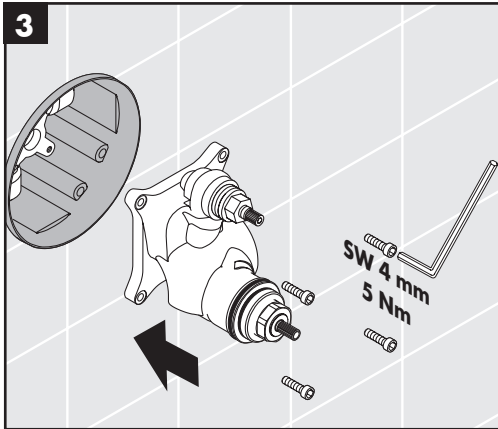
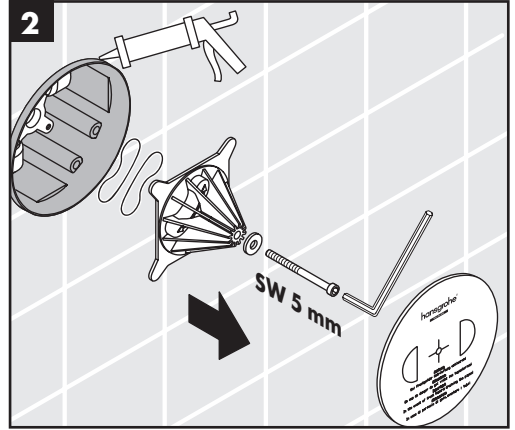
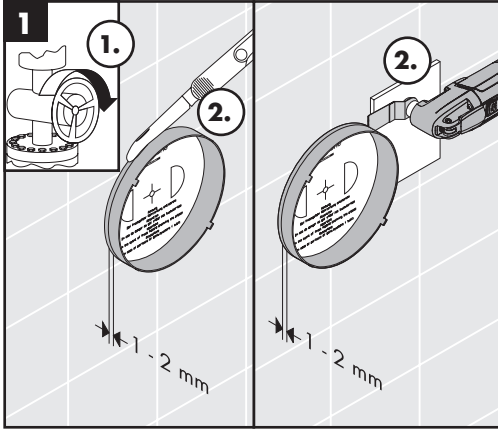

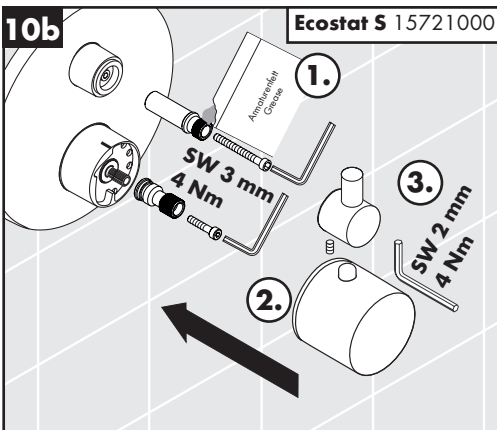
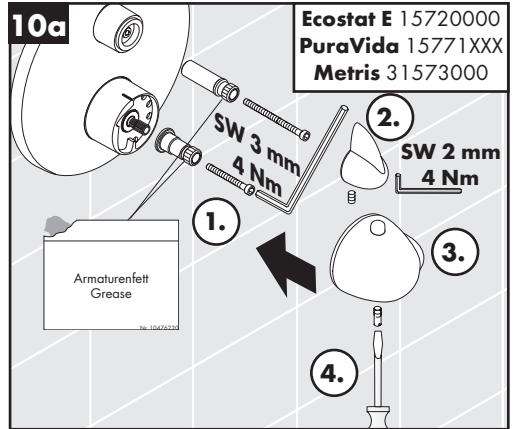
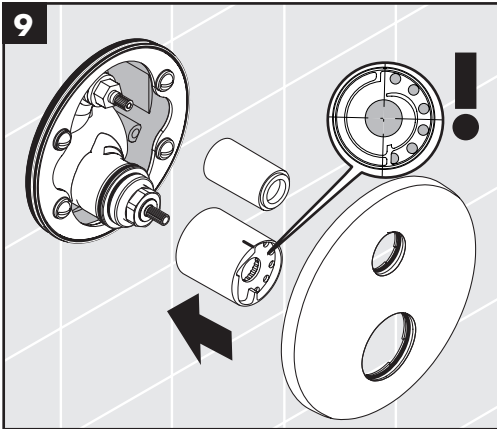
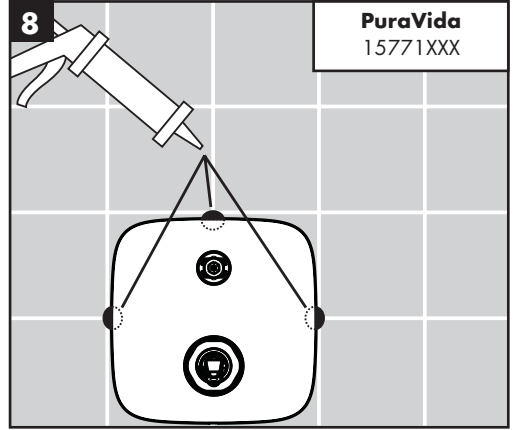
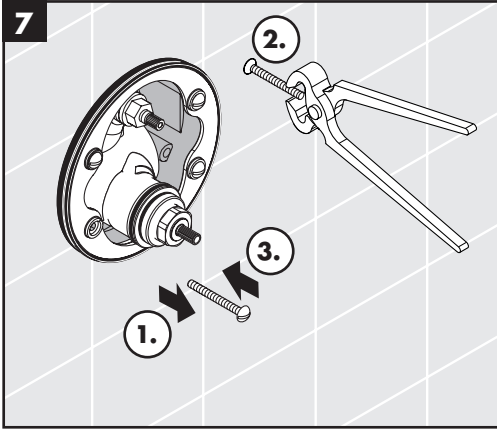

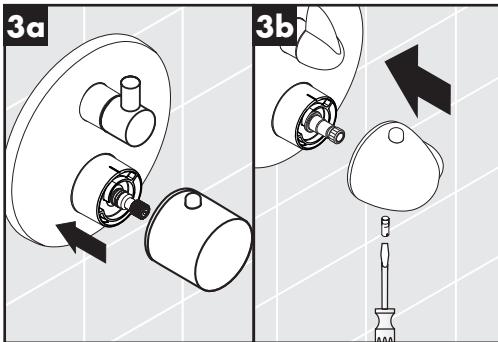
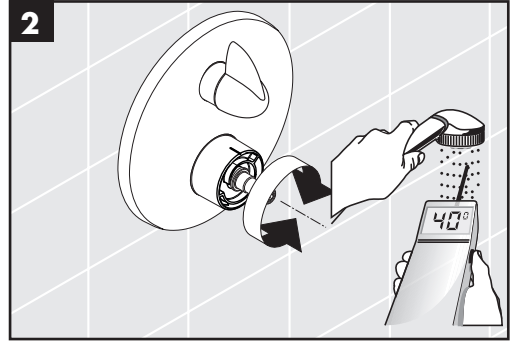
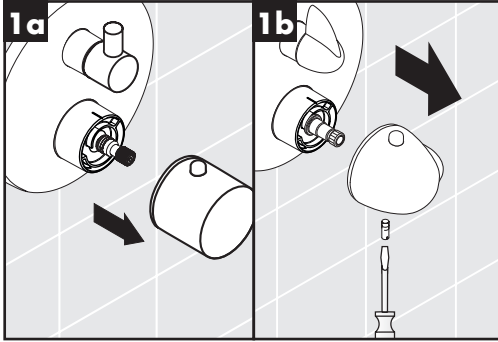

max.  
≈ 42°C

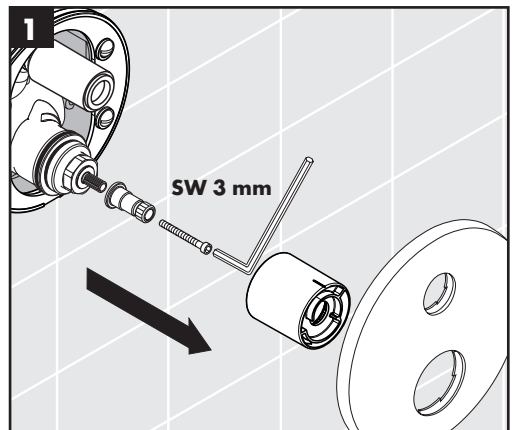
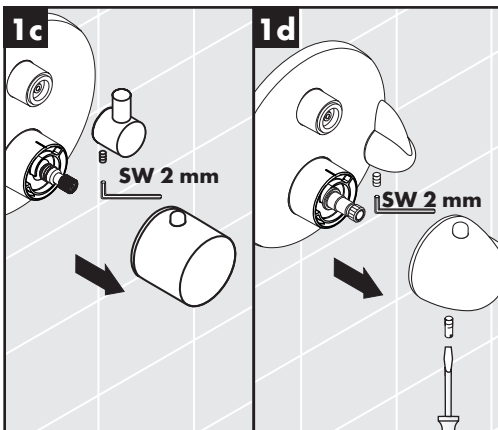

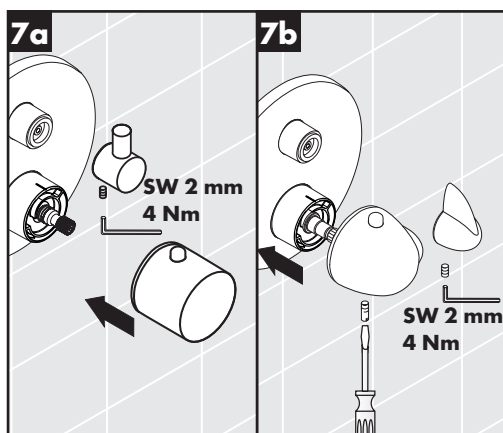
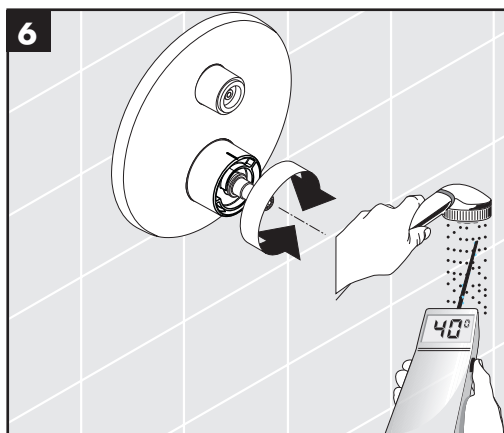
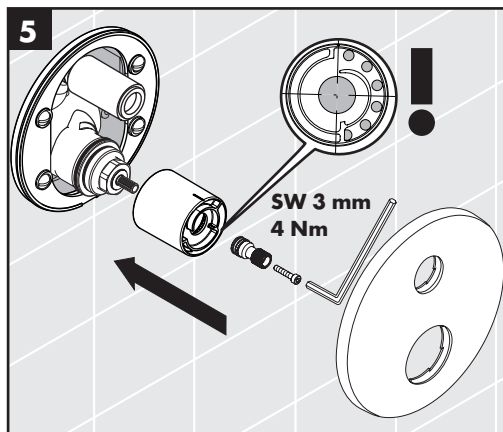
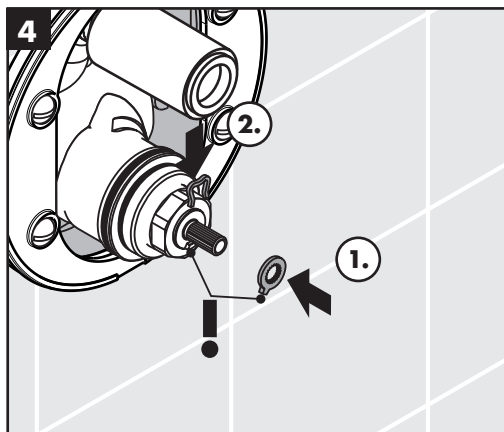
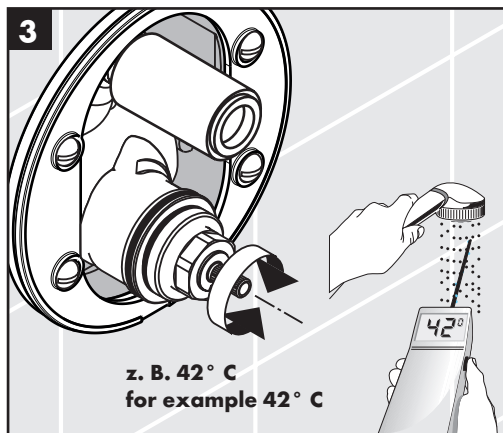
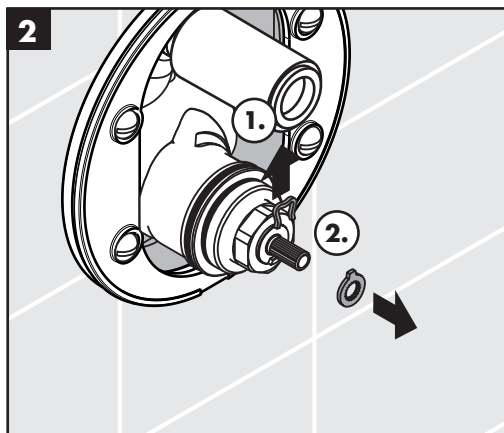

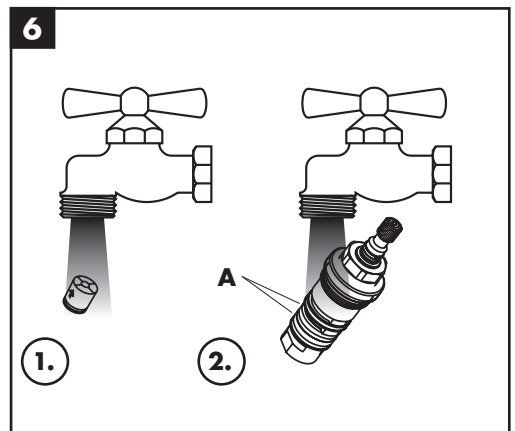
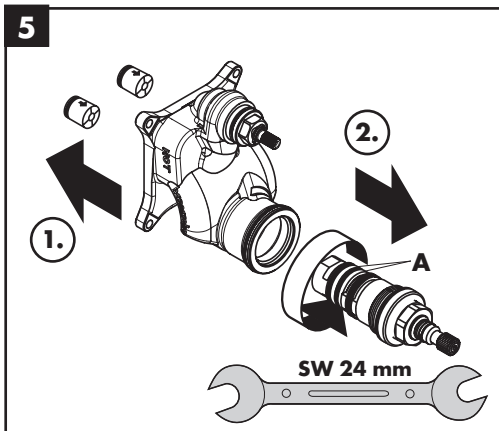
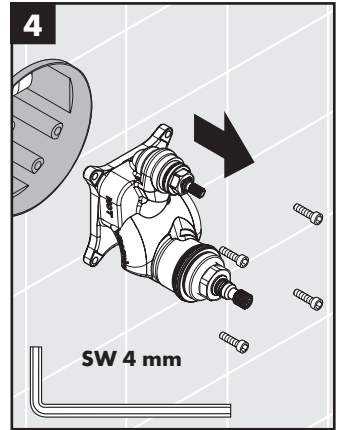
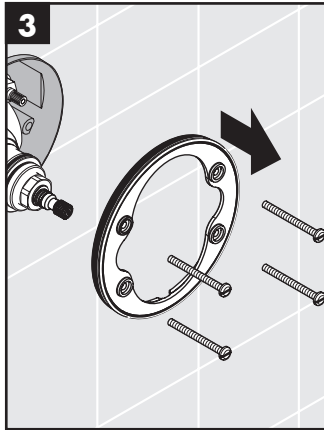
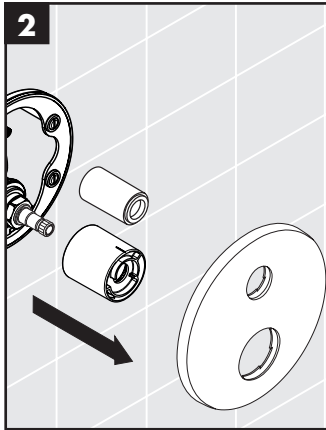
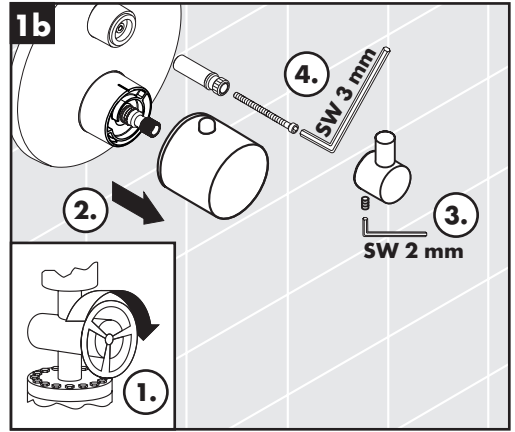
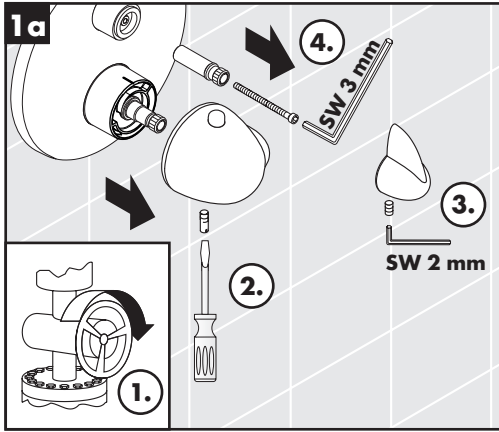



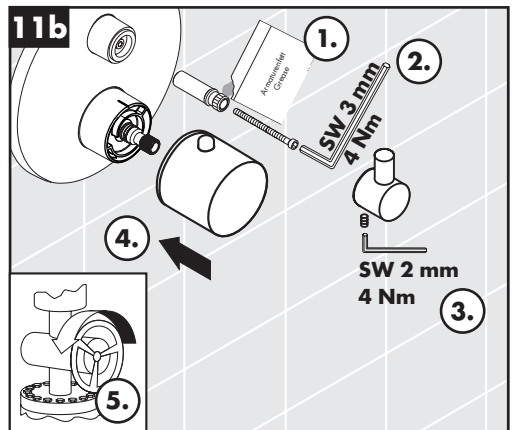
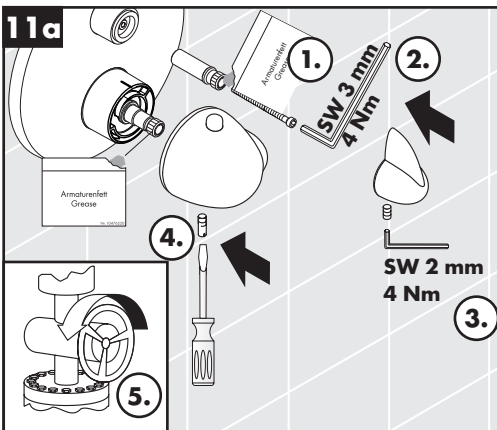
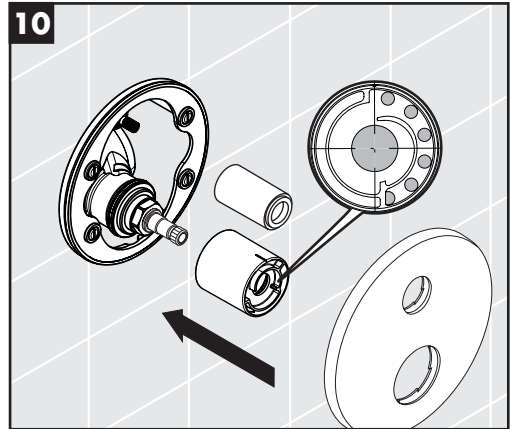
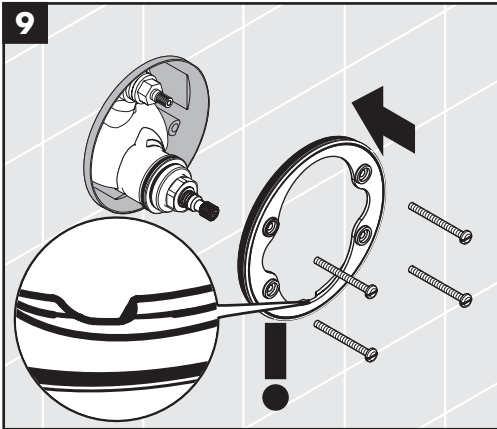
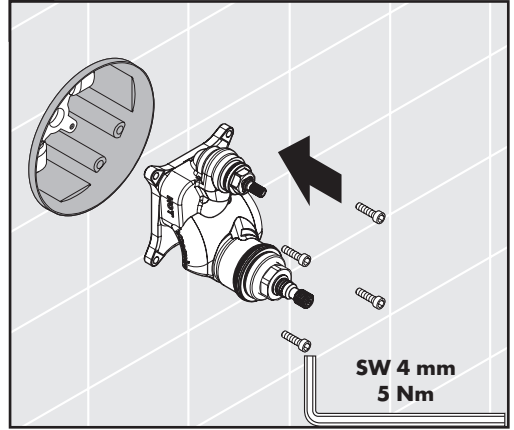
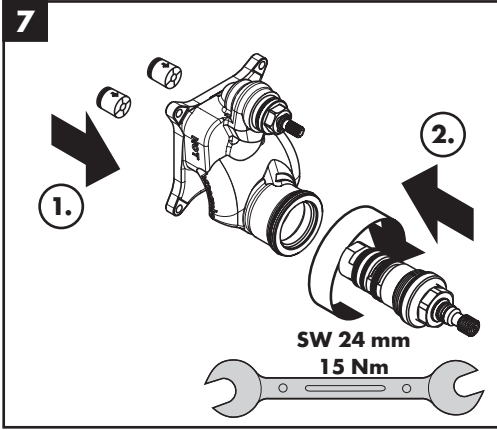

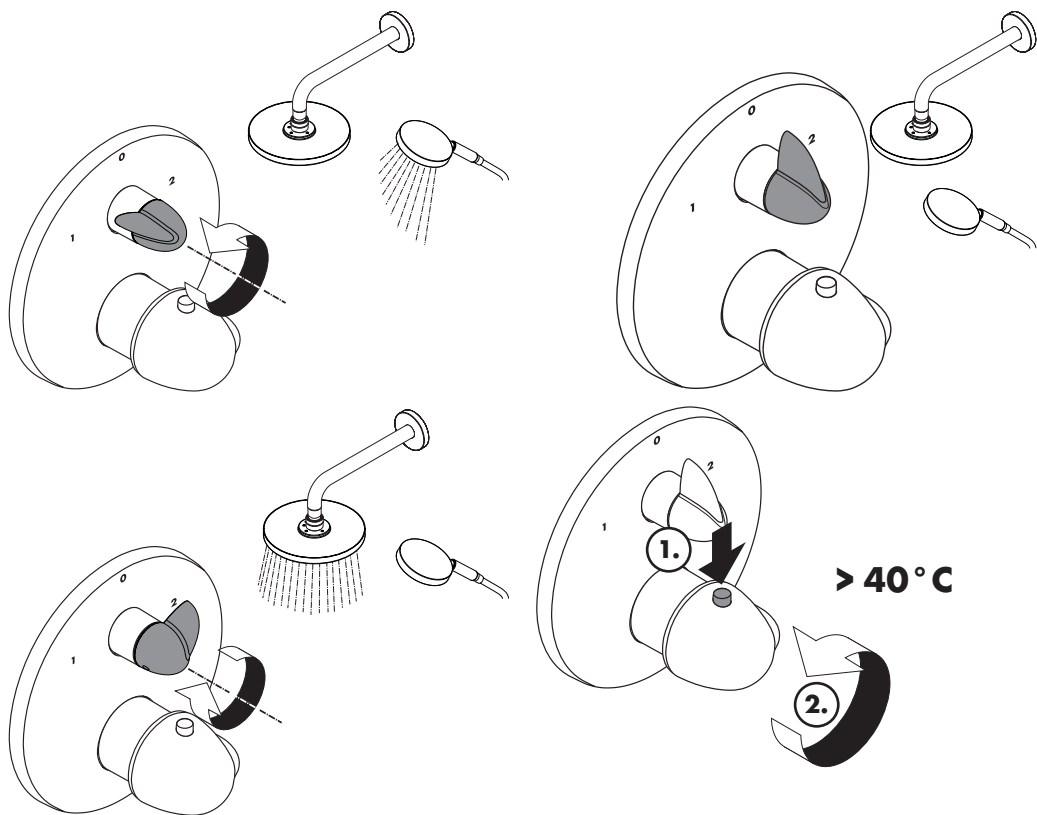

	P-IX	DVGW	SVGW	WRAS	KIWA	NF	ACS	ETA
<b>15720XXX</b>	PA-IX 9062/IAA	BT0550		X	X		X	VD 1.43/18753
<b>15721XXX</b>	PA-IX 9062/IAA	BT0550		X	X		X	VD 1.43/18753
<b>15771XXX</b>	PA-IX 9062/IAA			X	X		X	VD 1.43/18753
<b>31573000</b>	PA-IX 9062/IAA			X	X		X	VD 1.43/18753

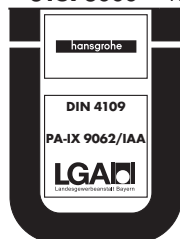



**Ecostat E 15720000**

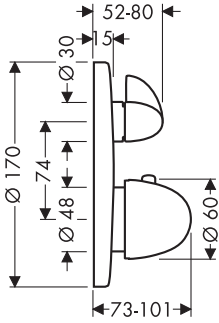

**Ecostat S 15721000**

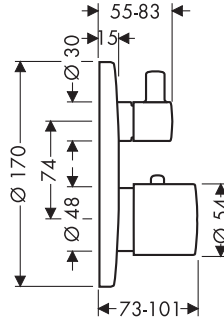

**PuraVida 15771XXX**

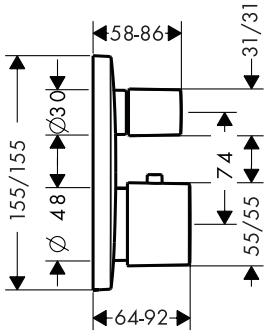

**Metris 31573000**

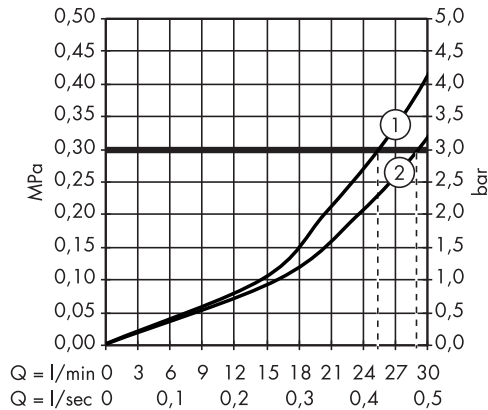
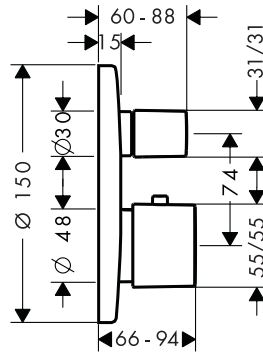



**Ecostat E 15720000 / Ecostat S 15721000 / PuraVida 15771XXX**

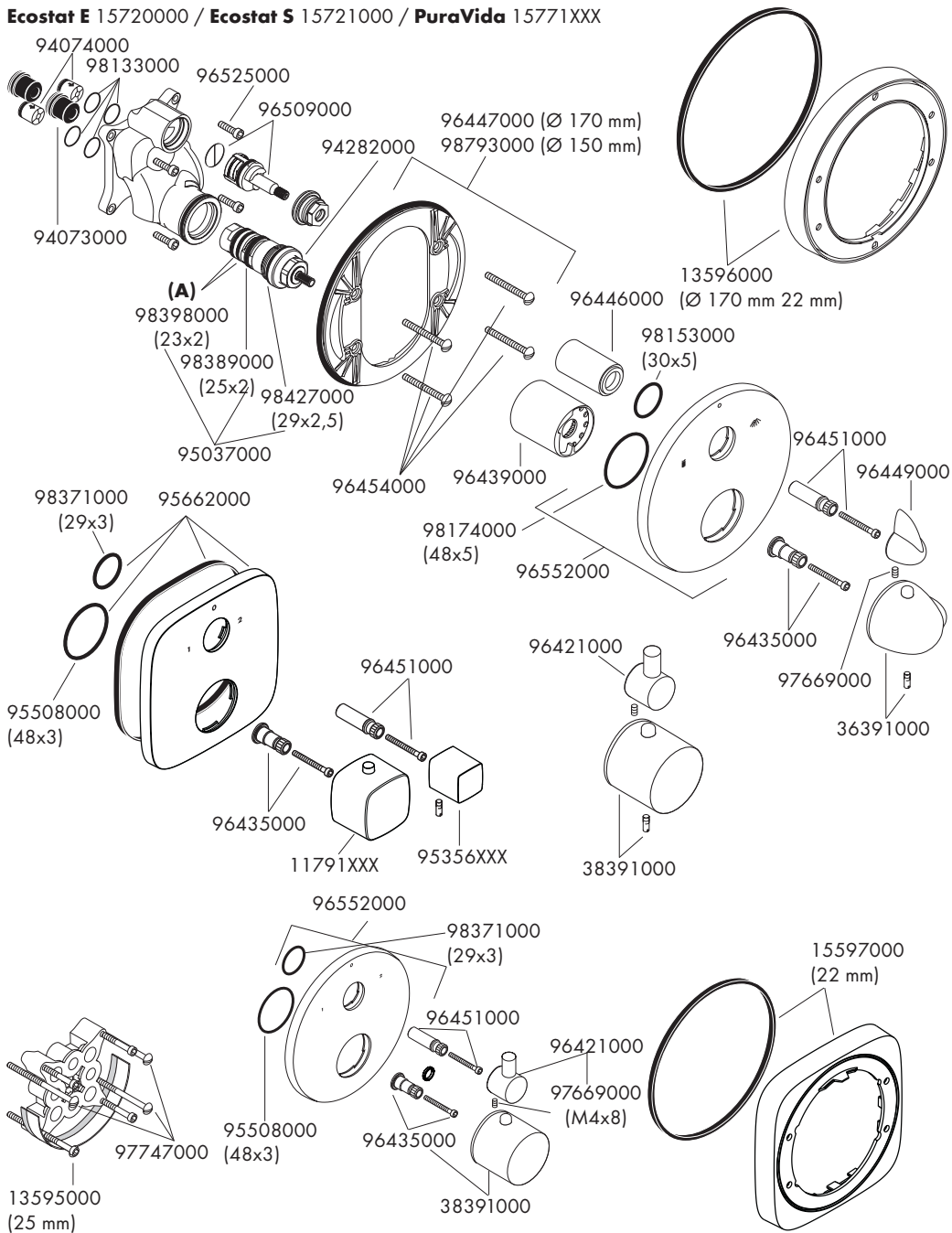



**Metris 31573000**

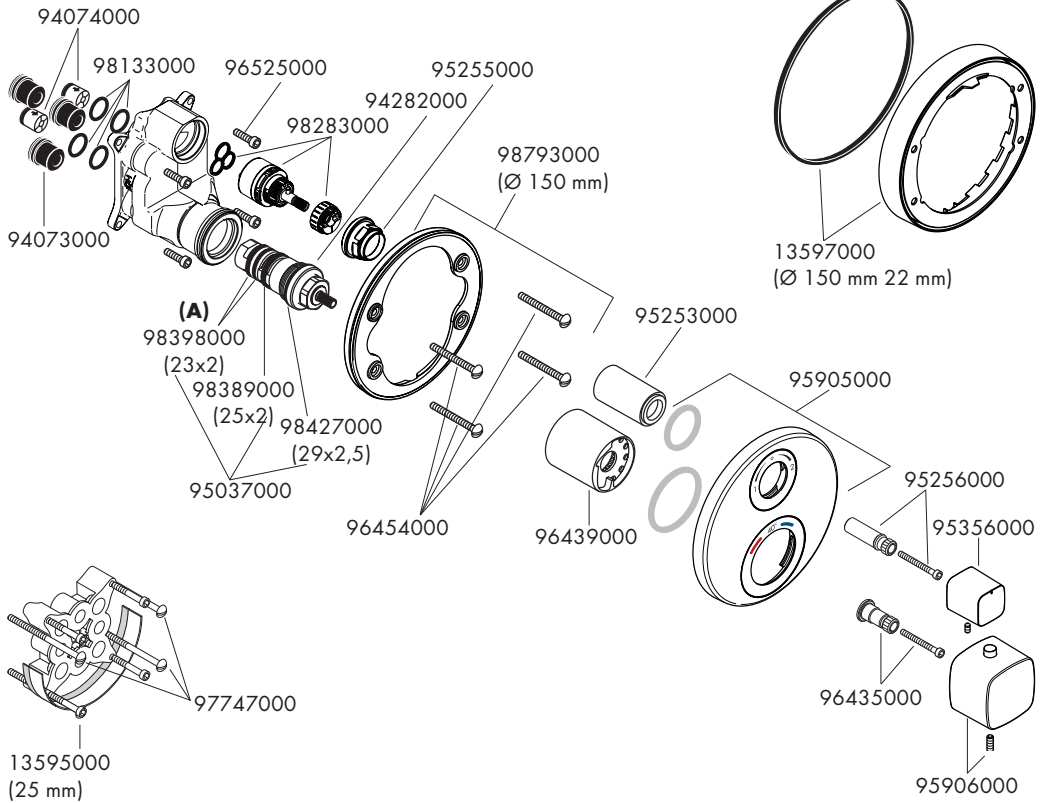



## On the following pages 70 - 75 you can find important information only for the installation in UK

### Safety and Important Information

Hansgrohe products are safe provided they are installed, used and maintained in accordance with these instructions and recommendations.

Please read these instructions thoroughly and retain for future use.

The plumbing installation of this thermostat mixing valve must comply with the requirements of UK Water Regulations/Bylaws (Scotland), Building Regulations or any other regulations specified by the local Water Authority and supplier.

The installation of thermostatic mixing valves must comply with the requirements of the Water Supply (Water Fittings) Regulations 1999.

We strongly recommend that you use a plumber registered with or a member of an Association:

Chartered Institute of Plumbing and Heating Engineering (CIPHE)  
Water Industry Approved Plumber Scheme (WIAPS)

Dispose of plastic bags carefully

Keep children well away from the work area.

Check for hidden pipes and cables in the wall before drilling holes.

The unit must be mounted on a finished waterproofed wall surface (usually tiles).

If you are using power tools (e.g. to drill holes) wear safety glasses and always disconnect tools from the power supply after use.

Do not operate the shower unit if the hand shower or spray hose has been damaged or is blocked.

Do not block the flow of water from the hand shower, by placing it on your hand or any other part of your body or foreign object.

The thermostatic unit should be serviced annually by a qualified person to ensure maximum safety during use.

The mixer is fitted with check valves (page 68 pos. 94074000). There are filters on the thermostatic element too (page 68 pos. A).

The fitting of isolation valves is required (preferred location page 72 Installation Requirements)

## Technical Data

This thermostatic valve will suit supplies of:  
HIGH PRESSURE (HP-S)

Operating pressure:	max. 10 bar
Recommended operating pressure:	1 - 5 bar
Test pressure:	16 bar
Hot water temperature:	max. 80 °C
Recommended hot water temp.:	65 °C
Rate of flow:	26 l/min. @ 3 bar
Maximum outlet temperature:	43 °C +/-*
Safety check:	40 °C
Hot water connection:	Left hand
Cold water connection:	Right hand
Minimum difference between hot water and mixed water temperature:	6 K
Hot and cold supply pressure should be balanced	

### Mixed water temperature

Application	Mixed water temperature (at point of discharge).
Shower	41 °C max.
Washbasin	41 °C max.
Bath (44 °C fill)	44 °C max.
Bath (46 °C fill)	46 °C max.

\* For preset outlet temperature adjustment – See page 62.

**NB.** If a water supply is fed by gravity then the supply pressure should be verified to ensure the conditions of use are appropriate for the valve. Valves operating outside of these supply conditions cannot be guaranteed to operate as a TMV2 or TMV3 valve.

### Recommended outlet temperatures

The BuildCert TMV scheme recommends the following set maximum mixed water outlet temperatures for use in all premises:

- 44 °C for bath fill but see notes below;
- 41 °C for showers;
- 41 °C for washbasins.

The mixed water temperatures must never exceed 46 °C. The maximum mixed water temperature can be 2 °C above the recommended maximum set outlet temperatures.

**Note:** 46 °C is the maximum mixed water temperature from the bath tap. The maximum temperature takes account of the allowable temperature tolerances inherent in thermostatic mixing valves and temperature losses in metal baths. It is not a safe bathing temperature for adults or children. The British Burns Association recommends 37 to 37.5 °C as a comfortable bathing temperature for children. In premises covered by the Care Standards Act 2000, the maximum mixed water outlet temperature is 43 °C

## Supply Conditions TMV2

Operating pressure range	High pressure
Maximum static pressure - bar	10
Flow pressure, hot and cold - bar	0.5 to 5
Hot supply temperature - °C	55 to 65
Cold supply temperature - °C	5 to 25

## Installation Requirements

This thermostatic mixer valve must be installed in compliance with current Water Regulations. If you have any doubts about the Water Regulation requirements contact your local water services provider or use the services of a professional plumber.

This mixer valve is suitable for use with the following water supply systems:





Gas Combination Boiler (multi-point) 1.0 - 10 bar\*  
Unvented System (pressure balanced) 1.0 - 10 bar  
Pumped System 1.0 - 10 bar

**IMPORTANT:** If you install this mixer with a gravity fed system, there must be a minimum head (vertical distance) from the underside of the cold water storage tank to the showerhead position of at least 5 metre.

Before connecting the mixer, water should be flushed through the system to remove all debris that might otherwise damage the valve.

\* If pressure is in excess of 3.5 bar, a pressure-reducing valve should be fitted.

**KEY**

-  Isolating valve
-  Reducing valve
-  Mixer Valve
-  Pump

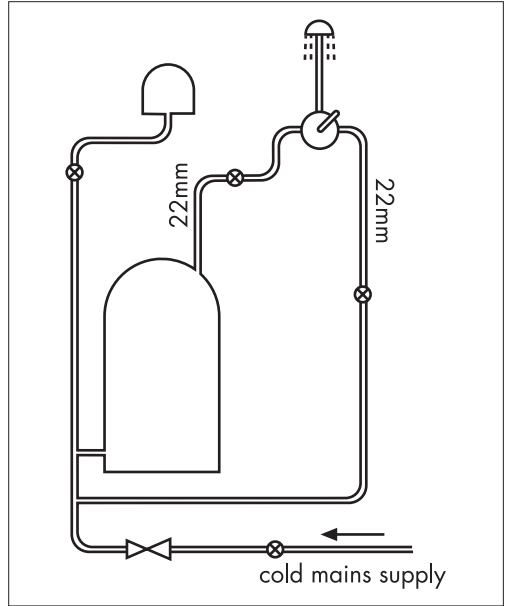

Unvented System (pressure balanced)

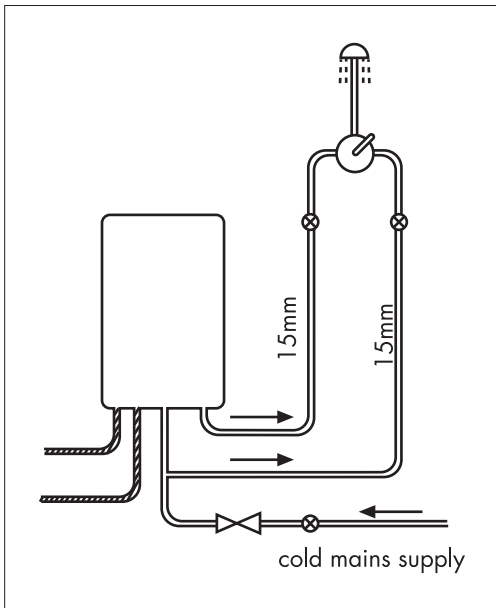

Gas Combination Boiler (multi-point)

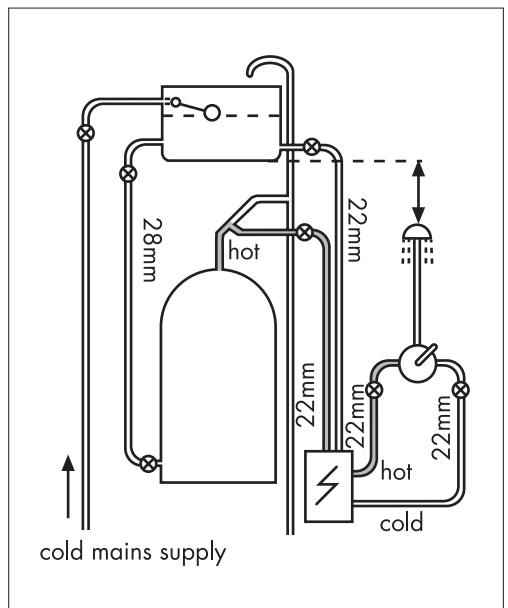

Pumped System



# Commissioning and in-service tests

## Commissioning

### Purpose

Since the installed supply conditions are likely to be different from those applied in the laboratory tests it is appropriate, at commissioning, to carry out some simple checks and tests on each mixing valve to provide a performance reference point for future in-service tests.

### Procedure

1. Check that:
  - a) the designation of the thermostatic mixing valve matches the intended application
  - b) the supply pressures are within the range of operating pressures for the designation of the valve
  - c) the supply temperatures are within the range permitted for the valve and by guidance information on the prevention of legionella etc.
2. Adjust the temperature of the mixed water in accordance with the manufacturer's instructions (page 62) and the requirement of the application and then carry out the following sequence:
  - a) record the temperature of the hot and cold water supplies
  - b) record the temperature of the mixed water at the largest draw-off flow rate
  - c) record the temperature of the mixed water at a smaller draw-off flow rate, which shall be measured
  - d) isolate the cold water supply to the mixing valve and monitor the mixed water temperature
  - e) record the maximum temperature achieved as a result of (d) and the final stabilised temperature

NOTE: The final stabilised mixed water temperature should not exceed the values in Table A.

- f) record the equipment, thermometer etc. used for the measurements

**Table A: Guide to maximum stabilised temperatures recorded during site tests**

<b>Application</b>	<b>Mixed water temperature</b>
Shower	43 °C
Washbasin	43 °C
Bath (44 °C fill)	46 °C
Bath (46 °C fill)	48 °C

The mixed water temperature at terminal fitting should never exceed 46°C.

If there is a residual flow during the commissioning or the annual verification (cold water supply isolation test), then this is acceptable providing the temperature of the water seeping from the valve is no more than 2 °C above the designated maximum mixed water outlet temperature setting of the valve.

Temperature readings should be taken at the normal flow rate after allowing for the system to stabilise.

The sensing part of the thermometer probe must be fully submerged in the water that is to be tested.

Any TMV that has been adjusted or serviced must be re-commissioned and re-tested in accordance with the manufacturers' instructions.

---

## In-service tests

### Purpose

The purpose of in-service tests is to regularly monitor and record the performance of the thermostatic mixing valve. Deterioration in performance can indicate the need for service work on the valve and/ or the water supplies.

### Procedure

1. Carry out the procedure **2.** (a) to (e) on page 73 using the same measuring equipment, or equipment to the same specifications.
2. If the mixed water temperature has changed significantly from the previous test results (e.g.  $> 1$  K), record the change and before re-adjusting the mixed water temperature check:
  - a) that any in-line or integral strainers are clean
  - b) any in-line or integral check valves or other anti-backsiphonage devices are in good working order
  - c) any isolating valves are fully open
3. With an acceptable mixed water temperature, complete the procedure **2.** (a) to (e) on page 73.
4. If at step **2.** (e) on page 73 the final mixed water temperature is greater than the values in Table A and / or the maximum temperature exceeds the corresponding value from the previous test results by more than about 2 K, the need for service work is indicated.

NOTE: In-service tests should be carried out with a frequency which identifies a need for service work before an unsafe water temperature can result. In the absence of any other instruction or guidance, the procedure described in „Frequency of in-service tests“ may be used.

## Frequency of in-service tests TMV3\*

### General

In the absence of any other instruction or guidance on the means of determining the appropriate frequency of in-service testing, the following procedure may be used:

1. 6 to 8 weeks after commissioning carry out the tests given in **2.** on page 73.
2. 12 to 15 weeks after commissioning carry out the tests given in **2.** on page 73.
3. Depending on the results of **1.** and **4.** several possibilities exist:
  - a) If no significant changes (e.g.  $\leq 1$  K) in mixed water temperatures are recorded between commissioning and **1.**, or between commissioning and **4.** the next in-service test can be deferred to 24 to 28 weeks after commissioning.
  - b) If small changes (e.g. 1 to 2 K) in mixed water temperatures are recorded in only one of these periods, necessitating adjustment of the mixed water temperature, then the next in-service test can be deferred to 24 to 28 weeks after commissioning.
  - c) If small changes (e.g. 1 to 2 K) in mixed water temperatures are recorded in both of these periods, necessitating adjustment of the mixed water temperature, then the next in-service test should be carried out at 18 to 21 weeks after commissioning.
  - d) If significant changes (e.g.  $> 2$  K) in mixed water temperatures are recorded in either of these periods, necessitating service work, then the next in-service test should be carried out at 18 to 21 weeks after commissioning.
4. The general principle to be observed after the first 2 or 3 in-service tests is that the intervals of future tests should be set to those which previous tests have shown can be achieved with no more than a small change in mixed water temperature.

**\*TMV2: The frequency of performing the in-service tests is 1 year maximum.**

---

# Thermostatic Adjustment

## Temperature Limitation

The temperature is limited by the safety stop to 40°C. If a higher temperature is required, it is possible to over ride the safety stop by depressing the safety button.

**NB.** It is recommended that for **private domestic use** the maximum mixed water temperature be set at the following factory set values:

Shower Mixer 43°C

Bath/Shower 43°C

Temperatures can be set by following the procedures on page 62. This ensures that after correct installation the outlet temperature of the water can never exceed 43°C.

To guarantee a smooth running of the thermostatic element, it is necessary from time to time to turn the thermostat from total hot to total cold. The thermostatic mixer valve should be checked annually by a qualified person to ensure correct operation.

The mixer is fitted with check valves (page 68 pos. 94074000) and filters (page 68 pos A). If the water flow drops the filters need to be cleaned. For that purpose please follow the steps 1 - 11 on page 64.

## Calibrating Thermostat

If the temperature reading is different to the showering temperature, follow the steps 1 - 3 on page 62.

### Technical Hotline

**0 870 7701975**

### E-mail

[Technical@hansgrohe.co.uk](mailto:Technical@hansgrohe.co.uk)

---

**hansgrohe**

Hansgrohe · AuestraÙe 5 · 9 · D-77761 Schiltach · Telefon +49 (0) 78 36/51-1282 · Telefax +49 (0) 7836/511440  
E-Mail: [info@hansgrohe.com](mailto:info@hansgrohe.com) · Internet: [www.hansgrohe.com](http://www.hansgrohe.com)

02/2013  
9,08851,07