

| | | |
|-----------|-----------------------------------------------------|-----------|
| DE | Gebrauchsanleitung / Montageanleitung | 2 |
| FR | Mode d'emploi / Instructions de montage | 3 |
| EN | Instructions for use / assembly instructions | 4 |
| IT | Istruzioni per l'uso / Istruzioni per Installazione | 5 |
| ES | Modo de empleo / Instrucciones de montaje | 6 |
| NL | Gebruiksaanwijzing / Handleiding | 7 |
| DK | Brugsanvisning / Monteringsvejledning | 8 |
| PT | Instruções para uso / Manual de Instalação | 9 |
| PL | Instrukcja obsługi / Instrukcja montażu | 10 |
| CS | Návod k použití / Montážní návod | 11 |
| SK | Návod na použitie / Montážny návod | 12 |
| ZH | 用户手册 / 组装说明 | 13 |
| RU | Руководство пользователя / Инструкция по монтажу | 14 |
| HU | Használati útmutató / Szerelési útmutató | 15 |
| FI | Käyttöohje / Asennusohje | 16 |
| SV | Bruksanvisning / Monteringsanvisning | 17 |
| LT | Vartotojo instrukcija / Montavimo instrukcijos | 18 |
| HR | Upute za uporabu / Uputstva za instalaciju | 19 |
| TR | Kullanım kılavuzu / Montaj kılavuzu | 20 |
| RO | Manual de utilizare / Instrucțiuni de montare | 21 |
| EL | Οδηγίες χρήσης / Οδηγία συναρμολόγησης | 22 |
| SL | Navodilo za uporabo / Navodila za montažo | 23 |
| ET | Kasutusjuhend / Paigaldusjuhend | 24 |
| LV | Lietošanas pamācība / Montāžas instrukcija | 25 |
| SR | Uputstvo za upotrebu / Uputstvo za montažu | 26 |
| NO | Bruksanvisning / Montasjeveiledning | 27 |
| BG | Инструкция за употреба / Инструкция за употреба | 28 |
| SQ | Udhëzuesi i përdorimit / Udhëzime rreth montimit | 29 |
| AR | دليل الاستخدام / تعليمات التجميع | 30 |

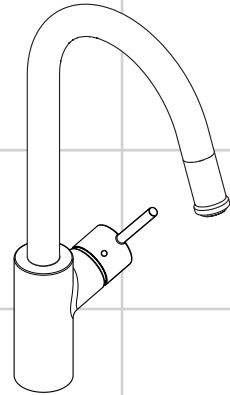

Talis S² Variarc
14872XXX

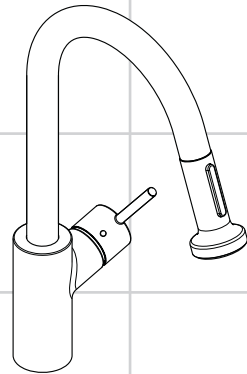

Talis S² Variarc
14877XXX



Sicherheitshinweise

- Bei der Montage müssen zur Vermeidung von Quetsch- und Schnittverletzungen Handschuhe getragen werden.
- Große Druckunterschiede zwischen den Kalt- und Warmwasseranschlüssen müssen ausgeglichen werden.

Montagehinweise

- Die Armatur muss nach den gültigen Normen montiert, gespült und geprüft werden!

Technische Daten

| | |
|----------------------------------|---------------|
| Betriebsdruck: | max. 1 MPa |
| Empfohlener Betriebsdruck: | 0,1 - 0,5 MPa |
| Prüfdruck: | 1,6 MPa |
| (1 MPa = 10 bar = 147 PSI) | |
| Heißwassertemperatur: | max. 80 °C |
| Empfohlene Heißwassertemperatur: | 65 °C |
| Durchflussleistung bei 0,3 MPa: | |
| Durchflussleistung Brausestrahl: | 11 l/min |
| Durchflussleistung Luftsprudler: | 9 l/min |
| Eigensicher gegen Rückfließen | |

Hansgrohe Armaturen können in Verbindung mit hydraulisch und thermisch gesteuerten Durchlauferhitzern eingesetzt werden, wenn der Fließdruck mindestens 0,15 MPa beträgt.

Symbolerklärung



Wartung (siehe Seite 34)

Rückflussverhinderer müssen gemäß DIN EN 1717 regelmäßig in Übereinstimmung mit nationalen oder regionalen Bestimmungen (DIN 1988 einmal jährlich) auf ihre Funktion geprüft werden.



Einhandmischer mit Warmwasserbegrenzung, Justierung siehe Seite 35. In Verbindung mit Durchlauferhitzern ist eine Warmwassersperre nicht notwendig.



Kein essigsäurehaltiges Silikon verwenden!



Maße (siehe Seite 31)



Serviceteile (siehe Seite 38)



Bedienung (siehe Seite 36)



Reinigung (siehe Seite 34)

Bei vermindertem Wasserdurchsatz Schmutzfangsieb zwischen Faustbrause und Schlauch reinigen.





Prüfzeichen (siehe Seite 40)



Montage siehe Seite 32



Consignes de sécurité

-  Lors du montage, porter des gants de protection pour éviter toute blessure par écrasement ou coupure.
-  Il est conseillé d'équilibrer les pressions de l'eau chaude et froide.

Instructions pour le montage

- La robinetterie doit être installée, rincée et contrôlée conformément aux normes valables!

Informations techniques

| | |
|---------------------------------|---------------|
| Pression de service autorisée: | max. 1 MPa |
| Pression de service conseillée: | 0,1 - 0,5 MPa |
| Pression maximum de contrôle: | 1,6 MPa |
| (1 MPa = 10 bar = 147 PSI) | |
| Température d'eau chaude: | max. 80 °C |
| Température recommandée: | 65 °C |
| Débit à 0,3 MPa: | |
| Débit du jet d'eau: | 11 l/min |
| Débit du tourbillon d'air: | 9 l/min |
| Avec dispositif anti-retour | |

Les mitigeurs Hansgrohe fonctionnent également en association à des chauffe-eau à commande hydraulique ou thermique à condition que la pression soit au minimum de 0,15 MPa.

Description du symbole



Entretien (voir page 34)

Les clapets anti-retour doivent être examinés régulièrement conformément à la norme EN 1717 ou conformément aux dispositions nationales ou régionales quant à leur fonction (au moins une fois par an).



Mitigeur avec limitation de la température: consulter la page 35 pour le réglage. Une limitation de la température n'est pas nécessaire quand le mitigeur est alimenté par un chauffe-eau instantané.



Ne pas utiliser de silicone contenant de l'acide acétique!



Dimensions (voir page 31)



Pièces détachées (voir pages 38)



Instructions de service (voir page 36)



Nettoyage (voir page 34)

En cas de baisse du débit dévisser la douchette poing et nettoyer le filtre.





Classification acoustique et débit (voir page 40)





Safety Notes

-  Gloves should be worn during installation to prevent crushing and cutting injuries.
-  The hot and cold supplies must be of equal pressures.

Installation Instructions

- The fitting must be installed, flushed and tested after the valid norms!

Technical Data

| | |
|---------------------------------|---------------|
| Operating pressure: | max. 1 MPa |
| Recommended operating pressure: | 0,1 - 0,5 MPa |
| Test pressure: | 1,6 MPa |
| (1 MPa = 10 bar = 147 PSI) | |
| Hot water temperature: | max. 80 °C |
| Recommended hot water temp.: | 65 °C |
| Rate of flow by 0,3 MPa: | |
| Handspray flow rate: | 11 l/min |
| Aerator flow rate: | 9 l/min |
| anti-pollution function | |

Hansgrohe mixers can be used together with hydraulically and thermally controlled continuous flow heaters if the flow pressure is at least 0,15 MPa.

Symbol description



Maintenance (see page 34)

The non return valves must be checked regularly according to DIN EN 1717 in accordance with national or regional regulations (at least once a year).



To adjust the hot water limiter on single lever mixers, please see page 35. No adjustment is necessary when using a continuous flow water heater.



Do not use silicone containing acetic acid!



Dimensions (see page 31)



Spare parts (see page 38)



Operation (see page 36)



Cleaning (see page 34)

If the waterflow drops, clean the filter located between hose and handspray.





Test certificate (see page 40)





Indicazioni sulla sicurezza

-  Durante il montaggio, per evitare ferite da schiacciamento e da taglio bisogna indossare guanti protettivi.
-  Attenzione! Compensare le differenze di pressione tra i collegamenti dell'acqua fredda e dell'acqua calda.

Istruzioni per il montaggio

- La rubinetteria deve essere installata, pulita e testata secondo le istruzioni riportate!

Dati tecnici

| | |
|---------------------------------------|---------------|
| Pressione d'uso: | max. 1 MPa |
| Pressione d'uso consigliata: | 0,1 - 0,5 MPa |
| Pressione di prova: | 1,6 MPa |
| (1 MPa = 10 bar = 147 PSI) | |
| Temperatura dell'acqua calda: | max. 80 °C |
| Temp. dell'acqua calda consigliata: | 65 °C |
| Potenza di erogazione a 0,3 MPa: | |
| Potenza di erogazione del getto: | 11 l/min |
| Potenza di erogazione del rompigitto: | 9 l/min |
| Sicurezza antiriflusso | |

I miscelatori Hansgrohe possono venire usati con caldaie a "bassa pressione" se la pressione di flusso è almeno di 0,15 MPa.

Descrizione simbolo



Manutenzione (vedi pagg.34)

La valvola di non ritorno deve essere controllata regolarmente come da DIN EN 1717, secondo le normative nazionali e regionali (almeno una volta all'anno).



Regolazione del limitatore di erogazione di acqua calda dei miscelatori monocomando, vedere pagina 35. In combinazione con le caldaie istantanee, il limitatore di erogazione di acqua calda non è necessario.



Non utilizzare silicone contenente acido acetico!



Ingombri (vedi pagg. 31)



Parti di ricambio (vedi pagg. 38)



Procedura (vedi pagg. 36)



Pulitura (vedi pagg. 34)

In caso di diminuzione dell'erogazione pulire il filtro situato tra la doccia ed il flessibile.



Segno di verifica (vedi pagg. 40)





Indicaciones de seguridad

- ⚠ Durante el montaje deben utilizarse guantes para evitar heridas por aplastamiento o corte.
- ⚠ Grandes diferencias de presión en servicio entre agua fría y agua caliente deben equilibrarse.

Indicaciones para el montaje

- El grifo tiene que ser instalado, probado y testado, según las normas en vigor.

Datos técnicos

| | |
|--------------------------------------|---------------|
| Presión en servicio: | max. 1 MPa |
| Presión recomendada en servicio: | 0,1 - 0,5 MPa |
| Presión de prueba: | 1,6 MPa |
| (1 MPa = 10 bar = 147 PSI) | |
| Temperatura del agua caliente: | max. 80 °C |
| Temp. recomendada del agua caliente: | 65 °C |
| Caudal a 0,3 MPa: | |
| Caudal chorro de ducha: | 11 l/min |
| Caudal aireador: | 9 l/min |
| Seguro contra el retorno | |

Los mezcladores Hansgrohe pueden ser utilizados junto con calentadores continuos de agua que sean manejados de manera hidráulica o térmica, siempre que la presión en servicio ascienda a un mínimo de 0,15 MPa.

Descripción de símbolos



Mantenimiento (ver página 34)

Las válvulas anti-retorno tienen que ser controladas regularmente según la norma DIN EN 1717, en acuerdo con las regulaciones nacionales o regionales (una vez al año, por lo menos).



Uso como mezclador monomando con limitación del caudal de agua caliente: ver ajuste en pagina 35. En combinación con calentadores instantáneos no es necesario limitar el caudal de agua caliente.



No utilizar silicona que contiene ácido acético!



Dimensiones (ver página 31)



Repuestos (ver página 38)



Manejo (ver página 36)



Limpiar (ver página 34)

En el caso que se redujera el caudal deberá limpiarse el filtro situado entre la ducha de mano y el tubo.





Marca de verificación (ver página 40)





Veiligheidsinstructies

-  Bij de montage moeten ter voorkoming van kniel- en snijwonden handschoenen worden gedragen.
-  Grote drukverschillen tussen de koud- en warmwater-toevoer dienen vermeden te worden.

Montage-instructies

- Leidingen doorspoelen volgens Norm. De mengkraan vervolgens monteren en controleren!

Technische gegevens

| | |
|------------------------------------|---------------|
| Werkdruk: max. | max. 1 MPa |
| Aanbevolen werkdruk: | 0,1 - 0,5 MPa |
| Getest bij: | 1,6 MPa |
| (1 MPa = 10 bar = 147 PSI) | |
| Temperatuur warm water: | max. 80°C |
| Aanbevolen warm water temp.: | 65°C |
| Doorvoercapaciteit bij 0,3 MPa: | |
| Doorstroomcapaciteit douchestraal: | 11 l/min |
| Doorstroomcapaciteit perlator: | 9 l/min |
| Beveiligd tegen terugstromen | |

Hansgrohe kranen kunnen samen met hydraulisch en thermisch gestuurde geisers gebruikt worden indien de uitstroomdruk min. 0,15 MPa bedraagt.

Symboolbeschrijving



Onderhoud (zie blz.34)

Keerkleppen moeten volgens DIN EN 1717 regelmatig en volgens plaatselijk geldende eisen op het functioneren gecontroleerd worden. (Tenminste een keer per jaar).



Eéngreepsmengkranen met warmwaterbegrenzing, instelling zie blz. 35. In combinatie met geisers is een warmwaterbegrenzing niet noodzakelijk.



Gebruik geen zuurhoudende siliconen!



Maten (zie blz. 31)



Service onderdelen (zie blz. 38)



Bediening (zie blz. 36)



Reinigen (zie blz. 34)

Bij verminderde waterdoorvoer zeefje tussen vuistdouche en slang schoonmaken.



Keurmerk (zie blz. 40)



Montage zie blz. 32



Sikkerhedsanvisninger

- ⚠ Ved monteringen skal der bruges handsker for at undgå kvæstelser og snitsår.
- ⚠ Større trykforskelle mellem koldt og varmt vand bør udjævnes.

Monteringsanvisninger

- Ifølge gældende regler, skal armaturet monteres, skylles igennem og afprøves.

Tekniske data

| | |
|-------------------------------------|---------------|
| Driftstryk: | max. 1 MPa |
| Anbefalet driftstryk: | 0,1 - 0,5 MPa |
| Prøvetryk: | 1,6 MPa |
| (1 MPa = 10 bar = 147 PSI) | |
| Varmvandstemperatur: | max. 80 °C |
| Anbefalet varmtvandstemperatur: | 65 °C |
| Gennemstrømningsydelse ved 0,3 MPa: | |
| Cirkulationsmængde brusestråle: | 11 l/min |
| Cirkulationsmængde luftdyse: | 9 l/min |
| Med indbygget kontraventil | |

Hansgrohe armaturer kan anvendes i forbindelse med hydraulisk- og termiskstyrede gennemstrømningsvandvarmere ved et vandtryk på 0,15 MPa.

Symbolbeskrivelse



Service (se s.34)

Ifølge DIN EN 1717 skal gennemstrømningsbegrænsere i overensstemmelse med nationale regler afprøves regelmæssigt (mindst en gang om året).



Etgrebsarmaturer med varmtvandsbegrænsning, justering se side 35. I forbindelse med gennemstrømningsvandvarmer er en varmtvandsbegrænsning ikke nødvendig.



Der må ikke benyttes eddikesyreholdig silikone!



Målene (se s. 31)



Reserve dele (se s. 38)



Brugsanvisning (se s. 36)



Rengøring (se s. 34)

Bij verminderde waterdoorvoer zeefje tussen vuistdouche en slang schoonmaken.



Godkendelse (se s. 40)





Avisos de segurança

- ⚠ Durante a montagem devem ser utilizadas luvas de protecção, de modo a evitar ferimentos resultantes de entalamentos e de cortes.
- ⚠ Grandes diferenças entre as pressões das águas quente e fria devem ser compensadas.

Avisos de montagem

- A misturadora deve ser instalada, purgada e testada de acordo com as normas em vigor!

Dados Técnicos

| | |
|----------------------------------|---------------|
| Pressão de funcionamento: | max. 1 MPa |
| Pressão de func. recomendada: | 0,1 - 0,5 MPa |
| Pressão testada: | 1,6 MPa |
| (1 MPa = 10 bar = 147 PSI) | |
| Temperatura da água quente: | max. 80 °C |
| Temp. água quente recomendada: | 65 °C |
| Caudal a 0,3 MPa: | 11 l/min |
| Caudal do emulsor: | 9 l/min |
| Função anti-retorno e anti-vácuo | |

As misturadoras Hansgrohe podem ser utilizadas com esquentadores (de controlo térmico ou hidráulico) desde que a pressão de utilização seja, no mínimo, de 0,15 MPa.

Descrição do símbolo



Manutenção (ver página 34)

As válvulas anti-retorno devem ser verificadas regularmente de acordo com a DIN EN 1717 segundo os regulamentos nacionais ou regionais (pelo menos uma vez por ano).



Misturadora monocomando equipada com limitador de temperatura (vide pág. 35). Em combinação com caldeira ou esquentador instantâneo o limitador de água quente não se aplica.



Não utilizar silicone que contenha ácido acético!



Medidas (ver página 31)



Peças de substituição (ver página 38)



Funcionamento (ver página 36)



Limpeza (ver página 34)

Se notar uma diminuição acentuada do caudal, convém limpar o filtro que está entre o flexível e a cabeça do chuveiro.



Marca de controlo (ver página 40)





Wskazówki bezpieczeństwa

- △ Aby uniknąć zranień, takich jak zgniecenia czy przecięcia, podczas montażu należy nosić rękawice.
- △ Znaczne różnice ciśnień na dopływach ciepłej i zimnej wody muszą zostać wyrównane.

Wskazówki montażowe

- Armatura musi być zamontowana, przepłukana i wypróbowana według obowiązujących norm!

Dane techniczne

| | |
|----------------------------------------------------|---------------|
| Ciśnienie robocze: | maks. 1 MPa |
| Zalecane ciśnienie robocze: | 0,1 - 0,5 MPa |
| Ciśnienie próbne: | 1,6 MPa |
| (1 MPa = 10 bary = 147 PSI) | |
| Temperatura wody gorącej: | maks. 80 °C |
| Zalecana temperatura wody gorącej: | 65 °C |
| Wydajność przepływu przy 0,3 MPa: | |
| Wydajność przepływu strumienia prysznica: | 11 l/min |
| Wydajność przepływu przez napowietrzacz: | 9 l/min |
| Samoistnie zabezpieczony przed przepływem zwrotnym | |

Armatura Hansgrohe może być stosowana z przepływowymi podgrzewaczami wody sterowanymi hydraulicznie i termicznie w przypadku, gdy ciśnienie przepływu wynosi co najmniej 0,15 MPa.

Opis symbolu



Konserwacja (patrz strona 34)

Działanie zabezpieczeń przed przepływem zwrotnym, zgodnie z normą DIN EN 1717 i miejscowymi przepisami, musi być kontrolowane (DIN 1988, raz w roku).



Mieszacz jednoręczny z ogranicznikiem temperatury wody, ustawianie, patrz str. 35. W połączeniu z przepływowym podgrzewaczem wody ogranicznik temperatury wody nie jest konieczny.



Nie stosować silikonów zawierających kwas octowy!



Wymiary (patrz strona 31)



Części serwisowe (patrz strona 38)



Obsługa (patrz strona 36)



Czyszczenie (patrz strona 34)

Przy niskim ciśnieniu wody, wyczyścić sitko pomiędzy prysznicem ręcznym a węzłem.





Znak jakości (patrz strona 40)





Bezpečnostní pokyny

-  Pro zabránění řezným zraněním a pohmožděninám je nutné při montáži nosit rukavice.
-  Je nutné vyrovnat velké rozdíly tlaku mezi přípoji studené a teplé vody.

Pokyny k montáži

- Armatura se musí montovat, proplachovat a testovat podle platných norem!

Technické údaje

| | |
|------------------------------------------|---------------|
| Provozní tlak: | max. 1 MPa |
| Doporučený provozní tlak: | 0,1 - 0,5 MPa |
| Zkušební tlak: | 1,6 MPa |
| (1 MPa = 10 bar = 147 PSI) | |
| Teplota horké vody: | max. 80 °C |
| Doporučená teplota horké vody: | 65 °C |
| Průtokové množství při 0,3 MPa: | |
| Průtokové množství sprchy: | 11 l/min |
| Průtokové množství perlátoru: | 9 l/min |
| Vlastní jističení proti zpětnému nasátí. | |

Armatury Hansgrohe je možno používat v kombinaci s hydraulicky a tepelně řízenými průtokovými ohřivači v případě, že tlak činí minimálně 0,15 MPa.

Popis symbolů



Údržba (viz strana 34)

U zpětných ventilů se musí podle DIN EN 1717 v souladu s národními nebo regionálními předpisy testovat jejich funkčnost (alespoň jednou ročně).



Páková baterie s omezením horké vody, seřízení viz. str. 35. Ve spojení s průtokovými ohřivači není uzávěr teplé vody nutný.



Nepoužívat silikon s obsahem kyseliny octové!



Rozměry (viz strana 31)



Servisní díly (viz strana 38)



Ovládání (viz strana 36)



Čištění (viz strana 34)

Při sníženém průtoku vyčistit sítko zachycující nečistoty mezi sprchou a hadicí.



Zkušební značka (viz strana 40)





Bezpečnostné pokyny

- ⚠ Pri montáži musíte nosiť rukavice, aby ste predišli pomliaždeninám a rezným poraneniam.
- ⚠ Veľké rozdiely v tlaku medzi prípojkami studenej a teplej vody musia byť vyrovnané.

Pokyny pre montáž

- Batéria sa musí montovať, preplachovať a testovať podľa platných noriem!

Technické údaje

| | |
|------------------------------------------|---------------|
| Prevádzkový tlak: | max. 1 MPa |
| Doporučený prevádzkový tlak: | 0,1 - 0,5 MPa |
| Skúšobný tlak: | 1,6 MPa |
| (1 MPa = 10 bar = 147 PSI) | |
| Teplota teplej vody: | max. 80 °C |
| Doporučená teplota teplej vody: | 65 °C |
| Prietokové množstvo pri 0,3 MPa: | |
| Prietokové množstvo prúdu vody v sprche: | 11 l/min |
| Prietokové množstvo perlatóra sprchy: | 9 l/min |
| Vlastná poistka proti spätnému nasatiu. | |

Batérie Hansgrohe môžete používať v spojení s hydraulickými a tepelne ovládanými prietokovými ohrievačmi, ak je tlak minimálne 0,15 MPa.

Popis symbolov



Údržba (viď strana 34)

Pri spätných ventiloch sa musí podľa DIN EN 1717 v súlade s národnými alebo regionálnymi predpismi testovať ich funkčnosť (aspoň raz ročne).



Páková batéria s obmedzením teplej vody, nastavenie viď.str. 35. V spojení s prietokovými ohrievačmi nie je uzáver teplej vody nutný.



Nepoužívať silikón s obsahom kyseliny octovej!



Rozmery (viď strana 31)



Servisné diely (viď strana 38)



Obsluha (viď strana 36)



Čistenie (viď strana 34)

Pri poklese prietoku vody vyčistíť filter umiestnený medzi hadicou a sífónom.



Osvedčenie o skúške (viď strana 40)





! 安全技巧

△ 装配时为避免挤压和切割受伤，必须戴上手套。

△ 冷热水管间过大的压力差必须予以平衡。

安装提示

• 必须按照现行的规定安装，冲洗和测试产品！

技术参数

| | |
|----------------------------|---------------|
| 工作压力: | 最大 1 MPa |
| 推荐工作压力: | 0,1 - 0,5 MPa |
| 测试压强: | 1,6 MPa |
| (1 MPa = 10 bar = 147 PSI) | |
| 热水温度: | 最大 80° C |
| 推荐热水温度: | 65° C |
| 流量 钟0,3 MPa: | |
| 花洒出水流量: | 11 升/分钟 |
| bar水压下，水波器出水流量: | 9 升/分钟 |
| 自动防止回流 | |

如果水压达到0,15 MPa以上，汉斯格雅双手柄龙头可以和液压式或热控式连续流热水器一起使用。

符号说明



保养 (参见第34 页)

单向阀必须在符合国家或当地的法律的情况下按照DIN EN 1717定期检查（至少一年一次）。



带有热水控制器的单手柄龙头的调节方法，参见第 35 页。如果与连续流热水器一起使用，则不必作任何调节。



请勿使用含有乙酸的硅！



大小 (参见第 31 页)



备用零件 (参见第 38 页)



操作 (参见第 36 页)



清洗 (参见第 34 页)

如果水流减少，清洁位于花洒头和软管之间的过滤网。



检验标记 (参见第 40 页)



安装 参见第 32 页



Указания по технике безопасности

- Во время монтажа следует надеть перчатки во избежание прищемления и порезов.
- донного клапа. Перед установкой смесителя необходимо регулировочными кранами выровнять давление холодной и горячей воды при помощи вентилей регулирующих подачу воды в квартиру.

Указания по монтажу

- Смеситель должен быть смонтирован по действующим нормам и в соответствии с настоящей инструкцией, проверен на герметичность и безупречность работы

Технические данные

| | |
|--------------------------------------------|-----------------|
| Рабочее давление: | не более. 1 МПа |
| Рекомендуемое рабочее давление: | 0,1 - 0,5 МПа |
| Давление: | 1,6 МПа |
| (1 МПа = 10 bar = 147 PSI) | |
| Температура горячей воды: | не более. 80 °С |
| Рекомендуемая темп. гор. воды: | 65 °С |
| Расход при 0,3 МПа: | |
| Пропускная способность струи душа: | 11 л/мин |
| Пропускная способность аэратора: | 9 л/мин |
| укомплектован клапаном обратного тока воды | |

Арматуры Hansgrohe могут использоваться в комбинации с проточными нагревателями с гидравлическим и термическим управлением, если давление истечения составляет не менее 0,15 МПа.

Описание символов



Техническое обслуживание (см. стр.34)

Защита обратного тока должна регулярно проверяться (минимум один раз в год) по стандарту DIN EN 1717 или в соответствии с национальными или региональными нормативами



Однорычажный смеситель имеет ограничитель расхода горячей воды (см. Стр. 35: юстировка).



Не применяйте силикон, содержащий уксусную кислоту.



Размеры (см. стр. 31)



Комплект (см. стр. 38)



Эксплуатация (см. стр. 36)



Очистка (см. стр. 34)

При сокращенном расходе воды очистите грязеуловитель между ручным душем и шлангом.





Знак технического контроля (см. стр. 40)





Biztonsági utasítások

-  A szerelésnél a zúródások és vágási sérülések elkerülése érdekében kesztyűt kell viselni.
-  A hidegvíz- és a melegvíz-csatlakozások közötti nagy nyomáskülönbséget kikell egyenlíteni!

Szerelési utasítások

- A csaptelepet az érvényben lévő előírásoknak megfelelően kell felszerelni, átöblíteni és ellenőrizni!

Műszaki adatok

| | |
|-------------------------------------|---------------|
| Üzemi nyomás: | max. 1 MPa |
| Ajánlott üzemi nyomás: | 0,1 - 0,5 MPa |
| Nyomáspróba: | 1,6 MPa |
| (1 MPa = 10 bar = 147 PSI) | |
| Forróvíz hőmérséklet: | max. 80 °C |
| Forróvíz javasolt hőmérséklete: | 65 °C |
| Átfolyási teljesítmény 0,3 MPa: | |
| Átfolyási teljesítmény, zuhanyugár: | 11 l/perc |
| Átfolyási teljesítmény, perlátor: | 9 l/perc |
| Visszafolyás gátlóval | |

A Hansgrohe csaptelepek hidraulikus és termikus vezérlésű átfolyós melegítőkkal kapcsolatban is használhatóak, ha az átfolyó nyomás legalább 0,15 MPa.

Szimbólumok leírása



Karbantartás (lásd a 34. oldalon)

A visszafolyásgátlók működése a DIN EN 1717 szabványnak megfelelően, a nemzeti vagy területi rendelkezésekkel összhangban, évente egyszer ellenőrizendő!



Az egykaros, melegvíz-korlátozóval ellátott keverő csaptelep beállítását lásd a 35. oldalon. Az átfolyó rendszerű vízmelegítőknél nem szükséges a melegvíz-korlátozó.



Ne használjon ecetsavtartalmú szilikon!



Méretet (lásd a 31. oldalon)



Tartozékok (lásd a 38. oldalon)



Használat (lásd a 36. oldalon)



Tisztítás (lásd a 34. oldalon)

Csökkent vízáteresztés esetén tisztítsa meg a kézi zuhany és a tömlő közti szennyfogó szűrőt.



Vizsgajel (lásd a 40. oldalon)



Szerelés lásd a 32. oldalon



Turvallisuusohjeet

- △ Asennuksessa on käytettävä käsineitä puristumien ja viiltojen aiheuttamien tapaturmien estämiseksi.
- △ Suuret paine-erot kylmä- ja kuumavesiliitäntöjen välillä on tasattava.

Asennusohjeet

- Kaluste on asennettava, huuhdeltava ja tarkastettava voimassa olevien määräysten mukaisesti!

Tekniset tiedot

| | |
|-------------------------------------|---------------|
| Käyttöpaine: | maks. 1 MPa |
| Suosittelut käyttöpaine: | 0,1 - 0,5 MPa |
| Koestuspaine: | 1,6 MPa |
| (1 MPa = 10 bar = 147 PSI) | |
| Kuuman veden lämpötila: | maks. 80 °C |
| Kuuman veden suosituslämpötila: | 65 °C |
| Läpivirtausmäärä 0,3 MPa paineella: | |
| Läpivirtausmäärä: | 11 l/min |
| Poresuuttimen läpivirtausmäärä: | 9 l/min |
| Estää itsestään paluuvirtauksen | |

Hansgrohe kalusteita voi käyttää hydraulisesti tai termisesti ohjattujen läpivirtauskuumentimien yhteydessä, jos virtauspaine on vähintään 0,15 MPa.

Merkin kuvaus



Huolto (katso sivu 34)

Vastaventtiilin toiminta on tarkastettava säännöllisesti paikallisten ja kansallisten määräysten mukaisesti (DIN 1988, kerran vuodessa).



Yksivipuinen sekoittaja lämpimän veden rajoituksella, katso säätö sivulta 35. Lämpimän veden rajoitusta ei tarvita läpivirtauskuumentimen yhteydessä.



Älä käytä etikahappopitoista silikonia!



Mitat (katso sivu 31)



Varaosat (katso sivu 38)



Käyttö (katso sivu 36)



Puhdistus (katso sivu 34)

Jos veden virtausmäärä pienenee, puhdista käsisuihkun ja letkun välissä oleva likasihti.





Koestusmerkki (katso sivu 40)





Säkerhetsanvisningar

-  Handskar ska bäras under monteringsarbetet så att man kan undvika kläm- och skärskadorna werden.
-  Stora tryckskillnader mellan anslutningarna för varmt och kallt vatten måste utjämnas.

Monteringsanvisningar

- Blandaren måste installeras, genomspolas och testas enligt gällande föreskrifter.

Tekniska data

| | |
|----------------------------------------------------------------|---------------|
| Driftstryck: | max. 1 MPa |
| Rek. driftstryck: | 0,1 - 0,5 MPa |
| Tryck vid provtryckning: (1 MPa = 10 bar = 147 PSI) | 1,6 MPa |
| Varmvattentemperatur: | max. 80 °C |
| Rek. varmvattentemp.: | 65 °C |
| Flödeskapacitet vid 0,3 MPa: | |
| Flödeskapacitet duschstråle: | 11 l/min |
| Genomströmningskapacitet perlator: Självspärr mot återflöde | 9 l/min |

Hansgrohe blandare kan användas tillsammans med hydrauliskt och termiskt styrda varmvattenberedare när flödestrycket uppgår till minst 0,15 MPa.

Symbolförklaring



Skötsel (se sidan 34)

Backventilens funktion måste kontrolleras regelbundet enligt nationella eller regionala bestämmelser (DIN 1988 en gång per år) i enlighet med DIN EN 1717.



Enhandsblandare med varmvattenreglering, justering se sidan 35. Vid användning tillsammans med varmvattenberedare behövs ingen varmvattenreglering.



Använd inte silikon som innehåller ättiksyra!



Mått (se sidan 31)



Reservdelar (se sidan 38)



Hantering (se sidan 36)



Rengöring (se sidan 34)

Om vattenflödet minskar behöver smutsfiltret mellan handduschen och slangen göras ren.





Testsigill (se sidan 40)





Saugumo technikos nurodymai

 Apsaugai nuo užspaudimo ir įsijovimo montavimo metu mūvėkite pirštines.

 Turi būti išlyginti šalto ir karšto slėgio nelygumai.

Montavimo instrukcija

- Maišytuvą privalo būti montuojamas, išleidžiamas ir patikrinamas pagal galiojančias normas!

Techniniai duomenys

| | |
|---------------------------------------------|-----------------------|
| Darbinis slėgis: | ne daugiau kaip 1 MPa |
| Rekomenduojamas slėgis: | 0,1 - 0,5 MPa |
| Bandomasis slėgis: | 1,6 MPa |
| (1 MPa = 10 barų = 147 PSI) | |
| Karšto vandens temperatūra: | ne daugiau kaip 80 °C |
| Rekomenduojama karšto vandens temperatūra: | 65 °C |
| Vandens pralaidumas, esant 0,3 MPa slėgiui: | |
| Vandens pralaidumas. Dušo srovė: | 11 l/min |
| Vandens pralaidumas. Oro kompresorius: | 9 l/min |
| Su atbuliniu vožtuvu | |

“Hansgrohe” maišytuvai gali būti naudojami su hidrauliškai ir termiškai reguliuojamais momentiniais šildikliais, kai vandens slėgis mažesnis kaip 0,15 MPa.

Simbolio aprašymas



Techninis aptarnavimas (žr. psl.34)

Atbulinio vožtuvo apsauga privalo būti tikrinama reguliariai (mažiausiai kartą per metus pagal DIN 1988) pagal DIN EN1717 arba pagal galiojančias nacionalines arba regionines normas.



Vienos rankenėlės maišytuvą turi karšto vandens ribotuvą (nustatymą žr. psl. 35). Naudojant momentinį šildiklį karšto vandens ribotuvą nebūtina.



Nenaudokite silikono, kurio sudėtyje yra acto rūgšties!



Išmatavimai (žr. psl. 31)



Atsarginės dalys (žr. psl. 38)



Eksploatacija (žr. psl. 36)



Valymas (žr. psl. 34)

Jei sumažėja vandens slėgis, išvalykite filtrą, esantį tarp žarnos ir dušelio rankoms.



Bandomo pažyma (žr. psl. 40)





Sigurnosne upute

- ⚠ Prilikom montaže se radi sprječavanja prignječenja i posjekotina moraju nositi rukavice.
- ⚠ Velika razlika u pritisku između vruće i hladne vode mora biti izbalansirana.

Upute za montažu

- Cijevi moraju biti postavljene, isprane i testirane prema važećim normama!

Tehnički podaci

| | |
|-------------------------------------|---------------|
| Najveći dopušteni tlak: | tlak 1 MPa |
| Preporučeni tlak: | 0,1 - 0,5 MPa |
| Probni tlak: | 1,6 MPa |
| (1 MPa = 10 bar = 147 PSI) | |
| Temperatura vruće vode: | tlak 80 °C |
| Preporučena temperatura vruće vode: | 65 °C |
| Protok vode uz tlak od 0,3 MPa: | |
| Protočni mlaz: | 11 l/min |
| Protok vode Prskanje: | 9 l/min |
| Funkcije samo-čišćenja | |

Hansgrohe armature mogu se koristiti u kombinaciji sa hidraulički i termički kontroliranim protočnim bojlerima ukoliko tlak iznosi najmanje 0,15 MPa

Opis simbola



Održavanje (pogledaj stranicu 34)

Ispravnost nepovratnog ventila mora se redovito provjeravati prema standardu DIN EN 1717 i u skladu sa važećim propisima (najmanje jednom godišnje).



Da bi podesili limiter vruće vode na jednoručnim slavinama molimo Vas da pogledate stranicu 35. Podešavanje nije potrebno ako koristite protočni bojler.



Nemojte koristiti silikon koji sadrži octenu kiselinu!



Mjere (pogledaj stranicu 31)



Rezervni djelovi (pogledaj stranicu 38)



Upotreba (pogledaj stranicu 36)



Čišćenje (pogledaj stranicu 34)

Ukoliko ne izlazi dovoljno vode, moguće je da se na filteru između tuša i cijevi nakupila prljavština. Očistite filter.



Oznaka testiranja (pogledaj stranicu 40)





⚠ Güvenlik uyarıları

- ⚠ Montaj esnasında ezilme ve kesilme gibi yaralanmaları önlemek için eldiven kullanılmalıdır.
- ⚠ Sıcak ve soğuk su bağlantıları arasında büyük basınç farklılıkları varsa, bu basınç farklılıklarının dengelenmesi gerekir.

Montaj açıklamaları

- Batarya geçerli normlara göre monte edilmeli, yıkanmalı ve kontrol edilmelidir!

Teknik bilgiler

| | |
|---------------------------------|---------------|
| İşletme basıncı: | azami 1 MPa |
| Tavsiye edilen işletme basıncı: | 0,1 - 0,5 MPa |
| Kontrol basıncı: | 1,6 MPa |
| (1 MPa = 10 bar = 147 PSI) | |
| Sıcak su sıcaklığı: | azami 80 °C |
| Tavsiye edilen su ısı: | 65 °C |
| 0,3 MPa'daki debi: | |
| Duş su akışındaki debi: | 1 l /dak |
| Perlatörün debisi: | 9 l /dak |
| Geri emme önleyici | |

Hansgrohe bataryaları, akış basıncı en az 0,15 MPa olursa hidrolik ve termik kumandalı şofbenlerle bağlantılı olarak kullanılabilir.

Simge açıklaması



Bakım (Bakınız sayfa 34)

DIN EN 1717 ve ulusal standartlar doğrultusunda Çek valfler düzenli olarak kontrol edilmelidir. (en az yılda bir kez)



Sıcak su sınırlayıcı özelliğine sahip tek kollu bataryanın ayarlanması için 35. sayfaya bakınız. Bir sürekli akışlı su ısıtıcısı ile birlikte kullanılırsa sıcak su sınırlayıcısına gerek kalmaz.



Asetik asit içeren silikon kullanmayın!



Ölçüleri (Bakınız sayfa 31)



Yedek Parçalar (Bakınız sayfa 38)



Kullanımı (Bakınız sayfa 36)



Temizleme (Bakınız sayfa 34)

Su debisinin azalması durumunda, el duşu ve hortum arasındaki filtreyi temizleyin.





Kontrol işareti (Bakınız sayfa 40)





Instrucțiuni de siguranță

-  La montare utilizați mănuși pentru evitarea contuziunilor și tăierii mâinilor.
-  Diferențele de presiune mari între alimentarea cu apă rece și apă caldă trebuie echilibrate.

Instrucțiuni de montare

- Bateria trebuie montată, clătită și verificată conform normelor în vigoare.

Date tehnice

| | |
|--------------------------------------------|---------------|
| Presiune de funcționare: | max. 1 MPa |
| Presiune de funcționare recomandată: | 0,1 - 0,5 MPa |
| Presiune de verificare: | 1,6 MPa |
| (1 MPa = 10 bar = 147 PSI) | |
| Temperatura apei calde: | max. 80°C |
| Temperatura recomandată a apei calde: | 65°C |
| Debit de apă la 0,3 MPa: | |
| Debitul de apă al dușului stropitor: | 11 l/min |
| Debitul de apă al pulverizatorului de aer: | 9 l/min |
| Asigurat contra scurgere înapoi | |

Bateriile Hansgrohe pot fi utilizate cu boiler instant cu comandă termică sau hidraulică dacă presiunea apei de alimentare este de min. 0,15 MPa.

Descrierea simbolurilor



Întreținere (vezi pag.34)

Supapele de reținere trebuie verificate regulat conform DIN EN 1717 și standardele naționale sau regionale (anual conform DIN 1988).



Bateria monocomadă cu limitarea apei calde, pentru reglare vezi pag. 35. Dacă conectați bateria la un boiler instant nu este necesară instalarea unui opritor de apă caldă.



Nu utilizați silicon cu conținut de acid acetic!



Dimensiuni (vezi pag. 31)



Piese de schimb (vezi pag. 38)



Utilizare (vezi pag. 36)



Curățare (vezi pag. 34)

În cazul unui debit redus de apă, curățați sita de impurități dintre capătul de duș și furtun.





Certificat de testare (vezi pag. 40)





Υποδειξεις ασφαλείας

-  Για να αποφύγετε τραυματισμούς κατά τη συναρμολόγηση πρέπει να φοράτε γάντια.
-  Οι διαφορές της πίεσης μεταξύ της σύνδεσης κρύου και ζεστού νερού θα πρέπει να αντισταθμίζονται.

Οδηγίες συναρμολόγησης

- Η κεντρική βάνα πρέπει να τοποθετηθεί, να πλυθεί και να ελεγχθεί με βάση τους ισχύοντες κανόνες υδραυλικής τέχνης!

Τεχνικά Χαρακτηριστικά

| | |
|-----------------------------------------------------|---------------|
| Λειτουργία πίεσης: | έως 1 MPa |
| Συνιστώμενη λειτουργία πίεσης: | 0,1 - 0,5 MPa |
| Πίεση ελέγχου: | 1,6 MPa |
| (1 MPa = 10 bar = 147 PSI) | |
| Θερμοκρασία ζεστού νερού: | έως 80 °C |
| Συνιστώμενη θερμοκρασία ζεστού νερού: | 65 °C |
| Κατανάλωση νερού στα 0,3 MPa: | |
| Κατανάλωση νερού σε δέσμη καταιονισμού στα 11 l/min | |
| Κατανάλωση νερού στο φίλτρο: | 9 l/min |
| Περιλαμβάνει βαλβίδα αντεπιστροφής. | |

Οι βάνες Hansgrohe μπορούν να συνδυαστούν με ταχυθερμοσίφωνες υδραυλικού και θερμικού ελέγχου, όταν η πίεση ροής αριθμεί τουλάχιστον 0,15 MPa.

Περιγραφή συμβόλων



Συντήρηση (βλ. σελίδα 34)

Οι βαλβίδες αντεπιστροφής πρέπει να ελέγχονται τακτικά ως προς τη λειτουργία τους, σύμφωνα με τις οδηγίες DIN EN 1717, σε σχέση με τους ισχύοντες εθνικούς ή τοπικούς κανόνες (το ελάχιστο μια φορά το χρόνο, σύμφωνα με το πρότυπο DIN 1988)



Για να προσαρμόσετε το δοσομετρητή ζεστού νερού σε αναμεικτικές μπαταρίες, παρακαλούμε δείτε τη ρύθμιση στη σελ. 35. Δεν είναι απαραίτητη η διάταξη φραγής ζεστού νερού σε συνδυασμό με ταχυθερμοσίφωνα.



Μην χρησιμοποιείτε σιλικόνη που περιέχει οξικό οξύ!



Διαστάσεις (βλ. σελίδα 31)



Ανταλλακτικά (βλ. σελίδα 38)



Χειρισμός (βλ. σελίδα 36)



Καθαρισμός (βλ. σελίδα 34)

Σε μειωμένη ροή νερού, καθαρίστε τα φίλτρο συλλογής ακαθαρσιών, που βρίσκεται ανάμεσα στον καταιονιστήρα χειρός και στο σωλήνα παροχής.





Σήμα ελέγχου (βλ. σελίδα 40)





Varnostna opozorila

-  Pri montaži je treba nositi rokavice, da se preprečijo poškodbe zaradi zmečkanja ali urezov.
-  Velike razlike v tlaku med priključkom za mrzlo in priključkom za toplo vodo je potrebno izravnati.

Navodila za montažo

- La robinetterie doit être installée, rincée et contrôlée conformément aux normes valables!

Tehnični podatki

| | |
|-------------------------------------|---------------|
| Delovni tlak: | maks. 1 MPa |
| Priporočeni delovni tlak: | 0,1 - 0,5 MPa |
| Preskusni tlak: | 1,6 MPa |
| (1 MPa = 10 bar = 147 PSI) | |
| Temperatura tople vode: | maks. 80 °C |
| Priporočena temperatura tople vode: | 65 °C |
| Pretok vode pri 0,3 MPa: | |
| Pretok vode curek prhe: | 11 l/min |
| Pretok vode curek perlatorja: | 9 l/min |
| Zaščita proti povratnemu toku | |

Armature Hansgrohe lahko uporabljate v povezavi s hidravlično in termično uravnanimi pretočnimi grelniki, če je pretočni tlak najmanj 0,15 MPa.

Opis simbola



Vzdrževanje (glejte stran 34)

Delovanje protipovratnega ventila je potrebno v skladu z DIN EN 1717 in skladno z državnimi in regionalnimi določili (DIN 1988 enkrat letno) redno testirati.



Enoročne mešalne baterije z omejevalnikom tople vode, za justiranje glejte stran 35. V povezavi s pretočnimi grelniki zapora tople vode ni potrebna.



Ne smete uporabiti silikona, ki vsebuje ocatno kislino!



Mere (glejte stran 31)



Rezervni deli (glejte stran 38)



Upravljanje (glejte stran 36)



Čiščenje (glejte stran 34)

Ob zmanjšanem pretoku vode očistite filter med ročno prho in gibko cevjo.





Preskusni znak (glejte stran 40)





Ohutusjuhised

-  Kandke paigaldamisel muljumis- ja löikevigastuste vältimiseks kindaid.
-  Kui külma ja kuuma vee ühenduste surve on väga erinev, tuleb need tasakaalustada.

Paigaldamisjuhised

- Segisti paigaldamine, loputamine ja kontroll peab toimuma vastavalt kehtivatele normidele!

Tehnilised andmed

| | |
|-----------------------------------|---------------|
| Töörõhk | maks. 1 MPa |
| Soovitatav töörõhk: | 0,1 - 0,5 MPa |
| Kontrollsurve: | 1,6 MPa |
| (1 MPa = 10 baari = 147 PSI) | |
| Kuuma vee temperatuur: | maks. 80 °C |
| Soovitatav kuuma vee temperatuur: | 65 °C |
| Läbivool, kui rõhk on 0,3 MPa: | |
| Duši läbivool: | 11 l/min |
| Läbivool õhustatuse korral: | 9 l/min |
| tagasivooluklapp | |

Hansgrohe segisteid võib kasutada koos hüdrauliliselt ja termiliselt juhitavate boileritega, kui vee surve on vähemalt 0,15 MPa.

Sümbolite kirjeldus



Hooldus (vt lk 34)

Tagasilöögiklappide toimimist tuleb kooskõlas riiklike ja regionaalsete määrustega regulaarselt kontrollida vastavalt standardile DIN EN 1717 (DIN 1988 - kord aastas).



Ühe juhtkangiga segisti kuuma vee piiraja reguleerimise kohta vt lk 35. Läbivoolu boilerite puhul pole reguleerimine vajalik.



Ärge kasutage äädikhapet sisaldavat silikooni!



Mõõtude (vt lk 31)



Varuosad (vt lk 38)



Kasutamine (vt lk 36)



Puhastamine (vt lk 34)

Kui vee läbivool on vähenenud, puhastage ära käsiduši ja vooliku vaheline filter.





Kontrollsertifikaat (vt lk 40)





Drošības norādes

-  Montāžas laikā, lai izvairītos no saspiedumiem un iegriezumiem, nepieciešams nēsāt cimdus.
-  Jāizlīdzina spiediena atšķirības starp aukstā un karstā ūdens pievadiem.

Norādījumi montāžai

- Armatūra jāuzstāda, jāizskalo un jāpārbauda atbilstoši spēkā esošajām normām!

Tehniskie dati

| | |
|---------------------------------------|---------------|
| Darba spiediens: | maks. 1 MPa |
| leteicamais darba spiediens: | 0,1 - 0,5 MPa |
| Pārbaudes spiediens: | 1,6 MPa |
| (1 MPa = 10 bar = 147 PSI) | |
| Karstā ūdens temperatūra: | maks. 80 °C |
| leteicamā karstā ūdens temperatūra: | 65 °C |
| Caurteces intensitāte pie 0,3 MPa: | |
| Caurteces intensitāte dušas strūklai: | 11 l/min |
| Caurteces intensitāte gaisa strūklai: | 9 l/min |
| Drošības vārsts | |

Hansgrohe jaucējkrānus var izmantot kombinācijā ar hidrauliski un termiski vadāmiem caurteces sildītājiem, ja plūsmas spiediens ir vismaz 0,15 MPa.

Simbolu nozīme



Apkope (skat.34. lpp.)

Regulāri jāpārbauda pretvārsta funkcija saskaņā ar DIN EN 1717 saistībā ar nacionālajiem vai vietējiem noteikumiem (DIN 1988 vienreiz gadā).



Viensvires jaucējkrāns ar siltā ūdens ierobežošanu, ieregulēšanu skat. 35. lpp. Kombinācijā ar caurteces sildītāju karstā ūdens ierobežošana nav nepieciešama.



Neizmantojiet silikonu, kas satur etiķskābi!



Izmērus (skat. 31. lpp.)



Rezerves daļas (skat. 38. lpp.)



Lietošana (skat. 36. lpp.)



Tīrīšana (skat. 34. lpp.)

Nepietiekamas ūdens plūsmas gadījumā jāiztīra filtrs, kas atrodas starp rokas dušu un šļūteni





Pārbaudes zīme (skat. 40. lpp.)





Sigurnosne napomene

-  Prilikom montaže se radi sprečavanja prignječenja i posekotine moraju nositi rukavice.
-  Velika razlika u pritisku između vruće i hladne vode mora biti izbalansirana.

Instrukcije za montažu

- Armatura mora biti postavljena, isprana i testirana prema važećim normama!

Tehnički podaci

| | |
|--------------------------------------|---------------|
| Radni pritisak: | maks. 1 MPa |
| Preporučeni radni pritisak: | 0,1 - 0,5 MPa |
| Probni pritisak: | 1,6 MPa |
| (1 MPa = 10 bar = 147 PSI) | |
| Temperatura vruće vode: | maks. 80 °C |
| Preporučena temperatura vruće vode: | 65 °C |
| Protok vode pri pritisku od 0,3 MPa: | |
| Protočni mlaz: | 11 l/min |
| Protok vode aerator: | 9 l/min |
| Zaštita od povratnog toka | |

Hansgrohe armature se mogu koristiti u kombinaciji s hidraulički i termički kontrolisanim protočnim bojlerima ukoliko pritisak iznosi najmanje 0,15 MPa.

Opis simbola



Održavanje (vidi stranu 34)

Ispravno funkcionisanje nepovratnog ventila se mora redovno proveravati prema standardu DIN EN 1717 i u skladu s važećim nacionalnim ili regionalnim propisima (DIN 1988 jednom godišnje).



Da bi ste podesili ograničavač vruće vode na jednoručnim mešačima, molimo Vas da pogledate stranicu 35. Podešavanje nije potrebno ako koristite protočni bojler.



Nemojte koristiti silikon koji sadrži sirćetnu kiselinu!



Mere (vidi stranu 31)



Rezervni delovi (vidi stranu 38)



Rukovanje (vidi stranu 36)



Čišćenje (vidi stranu 34)

Ukoliko ne izlazi dovoljno vode, moguće je da se na mrežici za hvatanje prljavštine, između glave i creva tuša, nakupila prljavština. Očistite filter.





Nepovratni ventil (vidi stranu 40)





Sikkerhetshenvisninger

-  Bruk hansker under montasjen for å unngå klem- og kuttskader.
-  Store trykkdifferanser mellom kaldt- og varmtvannstilkoblinger skal utlignes.

Montagehenvisninger

- Armaturen skal monteres iht. gyldige standarder. De skal spyles og sjekkes!

Tekniske data

| | |
|---------------------------------------|---------------|
| Driftstrykk | maks. 1 MPa |
| Anbefalt driftstrykk: | 0,1 - 0,5 MPa |
| Prøvetrykk | 1,6 MPa |
| (1 MPa = 10 bar = 147 PSI) | |
| Varmtvannstemperatur | maks. 80°C |
| Anbefalt temperatur for varmt vann | 65°C |
| Gjennomstrømningsytelse ved 0,3 MPa: | |
| Gjennomstrømningsytelse dusjstråle: | 11 l/min |
| Gjennomstrømningsytelse luftsprudler: | 9 l/min |
| Egensikker mot tilbakeflyt | |

Armaturer fra Hansgrohe kan brukes sammen med hydraulisk og termisk strypte gjennomstrømningsøvrer når gjennomstrømningstrykket er på minst 0,15 MPa.

Symbolbeskrivelse



Vedlikehold (se side 34)

Funksjonen til returløpssperren skal iht. DIN EN 1717 og i samsvar med de nasjonale og lokale forskrifter sjekkes regelmessig (DIN 1988 en gang i året).



Enhåndblandeblender med varmtvannsbegrensning. For justering se side 35. I forbindelse med en gjennomstrømningsøvrer er det ikke nødvendig med varmtvannsbegrensning.



Ikke bruk silikon som inneholder eddiksyre!



Mål (se side 31)



Service-deler (se side 38)



Betjening (se side 36)



Rengjøring (se side 34)

Ved forminskert vanngjennomstrømning skal smussfilteret mellom hånddusj og slangen renses.



Prøvemerket (se side 40)





Указания за безопасност

- ⚠ При монтажа трябва да се носят ръкавици, за да се избегнат наранявания поради притискане или порязване.
- ⚠ Големите разлики в налягането между изводите за студената и топлата вода трябва да се изравняват.

Указания за монтаж

- Арматурата трябва да се монтира, промие и провери в съответствие с валидните норми!

Технически данни

| | |
|----------------------------------------------|---------------|
| Работно налягане: | макс. 1 МПа |
| Препоръчително работно налягане: | 0,1 - 0,5 МПа |
| Контролно налягане: | 1,6 МПа |
| (1 МПа = 10 bar = 147 PSI) | |
| Температура на горещата вода: | макс. 80 °C |
| Препоръчителна температура на горещата вода: | 65 °C |
| Мощност на потока при 0,3 МПа: | |
| Мощност на потока разпръскваща струя: | 11 л/мин |
| Мощност на потока аератор: | 9 л/мин |
| Самозащитен против обратно изтичане | |

Арматурите на Hansgrohe могат да се използват във връзка с хидравлично и термично управляеми проточни нагреватели, ако хидравличното налягане е минимум 0,15 МПа.

Описание на символите



Поддръжка (вижте стр.34)

Съгласно DIN EN 1717 редовно трябва да се проверява функционирането на приспособленията за предотвратяване на обратния поток в съответствие с националните или регионални изисквания (DIN 1988 веднъж годишно).



Смесител с една ръкохватка с ограничител за топлата вода, юстирането вижте на стр. 35. Във връзка с проточни нагреватели не е необходима блокировка за топлата вода.



Не използвайте силикон, съдържащ оцетна киселина!



Размери (вижте стр. 31)



Сервизни части (вижте стр. 38)



Обслужване (вижте стр. 36)



Почистване (вижте стр. 34)

При намалена пропускателна способност на водата почистете цедката за улавяне на замърсявания между изтеглящия се разпръсквател за кухненската мивка и маркуча.





Контролен знак (вижте стр. 40)



Монтаж вижте стр. 32



Udhëzime sigurie

-  Për të evituar lëndimet e pickimeve ose të prerjeve gjatë procesit të montimit duhet që të vishni doreza.
-  Ndryshimet e mëdha të presionit mes lidhjeve të ujit të ftohtë dhe atij të ngrohtë duhen ekuilibruar.

Udhëzime për montimin

- Armatura duhet montuar, shpërlarë dhe kontrolluar në bazë të normave të vlefshme!

Të dhëna teknike

| | |
|----------------------------------------------------|---------------|
| Presioni gjatë punës | maks. 1 MPa |
| Presioni i rekomanduar: | 0,1 - 0,5 MPa |
| Presioni për provë: | 1,6 MPa |
| (1 MPa = 10 bar = 147 PSI) | |
| Temperatura e ujit të ngrohtë | maks. 80 °C |
| Temperatura e rekomanduar e ujit të ngrohtë: | 65 °C |
| Kapaciteti i rrjedhjes në 0,3 MPa: | |
| Kapaciteti i rrjedhjes në currilit të spërkatëses: | 11 l/min |
| Kapaciteti i rrjedhjes së perlatorit: | 9 l/min |
| Siguresa kundër rrjedhjes në drejtim të kundërt | |

Armaturat e Hansgrohe mund të përdoren në kombinim me ngrohës elektrikë të ujit të drejtuar në mënyrë hidraulike ose termike nëse presioni i rrjedhjes është minimumi 0,15 MPa.

Përshkrimi i simbolit



Mirëmbajtja (shih faqen 34)

Penguesit e rrjedhjes në drejtim të kundërt duhen kontrolluar rregullisht në bazë të normave DIN EN 1717 konform normave nacionale dhe regionale (DIN 1988 një herë në vit).



Rubinet me ujë të përzier me kufizim të ujit të ngrohtë, justimi shih faqen 35. Në kombinim me ngrohësit elektrikë të ujit nuk ka nevojë për bllokadë të ujit të ngrohtë.



Mos përdorni silikon që në përbërje ka acid acetik.



Përmasat (shih faqen 31)



Pjesë ndërrimi (shih faqen 38)



Përdorimi (shih faqen 36)



Pastrimi (shih faqen 34)

Nëse pakësohet vëllimi i ujit, atëherë pastroni sitën për mbledhjen e ndotjeve që ndodhet mes spërkatëses në formë grushti dhe tubit.



Shenja e kontrollit (shih faqen 40)





وصف الرمز

الصيانة (راجع صفحة 34)



يجب فحص صمام عدم الرجوع بصفة منتظمة حسب المواصفة DIN EN 1717 وذلك طبقاً للوائح الوطنية أو الإقليمية (مرة واحد سنوياً) طبقاً للمواصفة DIN (1988).

لضبط محدد الماء الساخن في الخلاطات ذات المقبض الواحد، يرجى الرجوع إلى صفحة 35. ولا يلزم إجراء أي ضبط عند استخدام سخان مياه ذي تدفق مستمر.

هام! لا تستخدم السليكون الذي يحتوي على أحماض!

أبعاد (راجع صفحة 31)

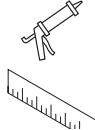

قطع الغيار (راجع صفحة 38)



التشغيل (راجع صفحة 36)



التنظيف (راجع صفحة 34)



إذا انخفض معدل تدفق المياه، قم بتنظيف المرشح (الفلتر) الموجود بين الخرطوم والرشاش اليدوي.

شهادة اختبار (راجع صفحة 40)



تنبيهات الأمان



⚠ يجب ارتداء قفازات لليد أثناء التركيب لتجنب حدوث أضرار الإنحشار أو الجروح.

⚠ يجب أن يكون تيار الماء الساخن والماء البارد متعادلين في الضغط.

تعليمات التركيب

يجب تركيب الوصلة، وغمرها بالماء واختبارها وفقاً للمعايير السارية! **المواصفات الفنية**

ضغط التشغيل: الحد الأقصى 1 ميجاباسكال
ضغط التشغيل الموصى به: 0,1 - 0,5 ميجاباسكال
ضغط الاختبار: 1,6 ميجاباسكال

(1 ميجاباسكال = 10 بار = 147 PSI)
الحد الأقصى 80°C
درجة حرارة الماء الساخن: 65°C

درجة الحرارة الموصى بها للماء الساخن:
معدل التدفق عند ضغط 0,3 ميجاباسكال:
فدرة تدفق الماء من الدش:
قدرة التدفق من تجهيزة التهوية (تجهيزة توزيع المياه):
خاصية عدم التدفق العكسي

يمكن استخدام خلاطات هانزجر وهي مع سخانات تدفق الماء ذات التحكم الهيدروليكي و الحراري، مع ضغط تدفق لا يقل عن 0,15 ميجاباسكال.





Talis S² Variarc 14872XXX

Talis S² Variarc 14877XXX

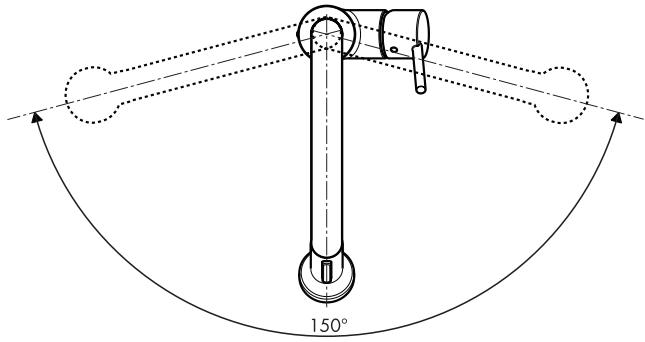
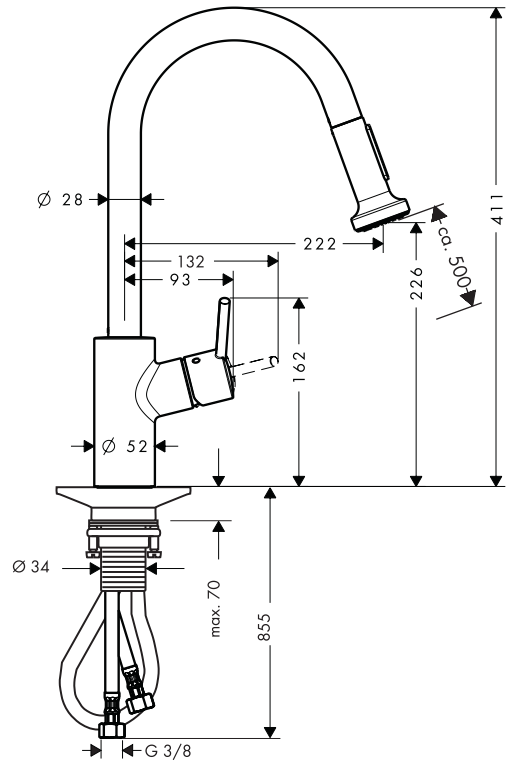
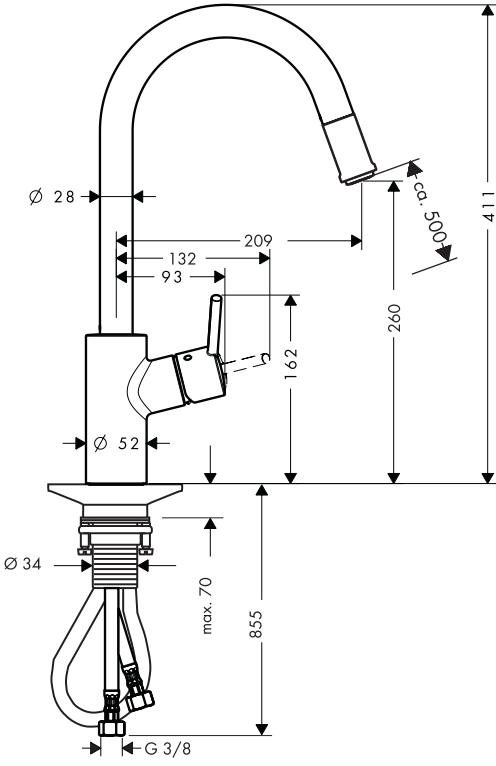

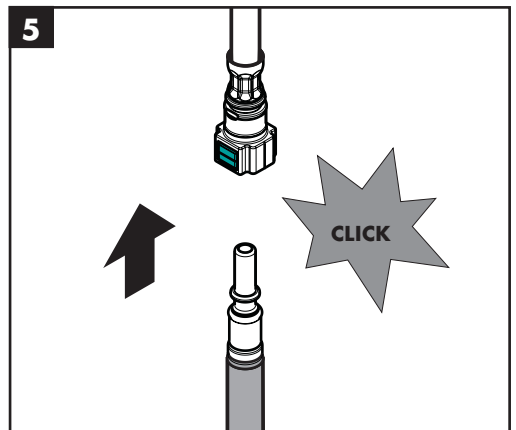
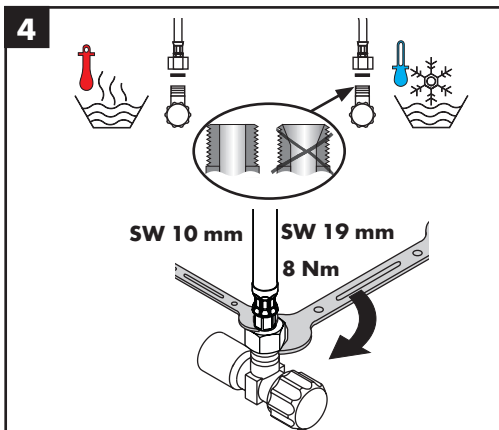
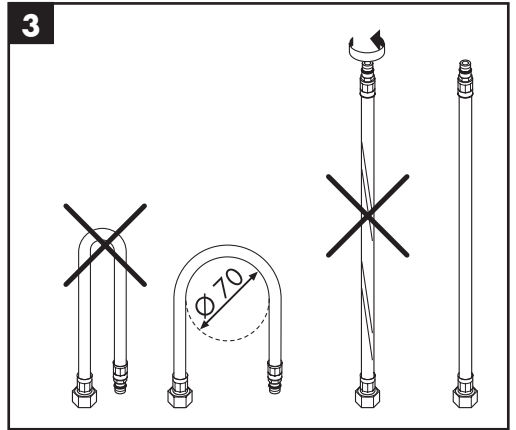
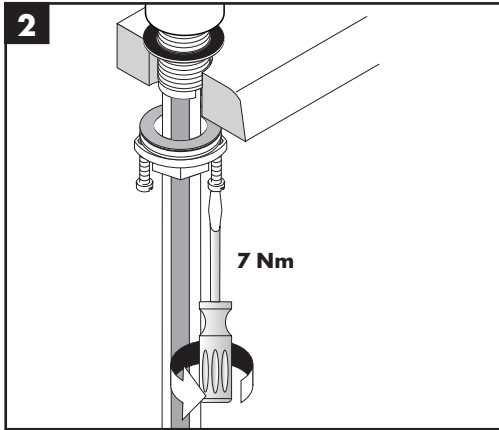
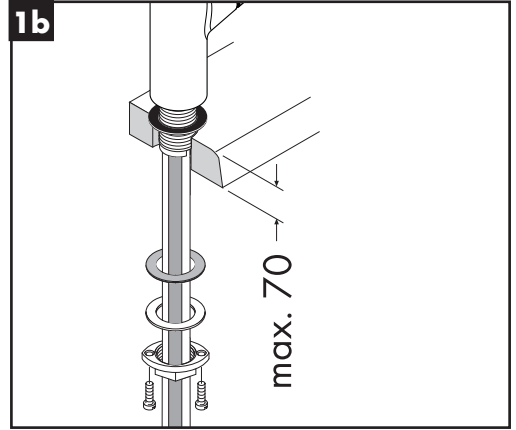
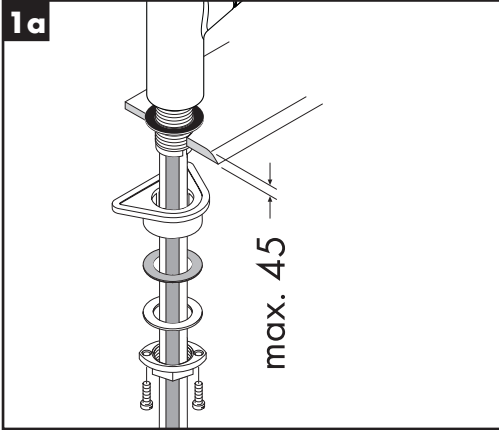

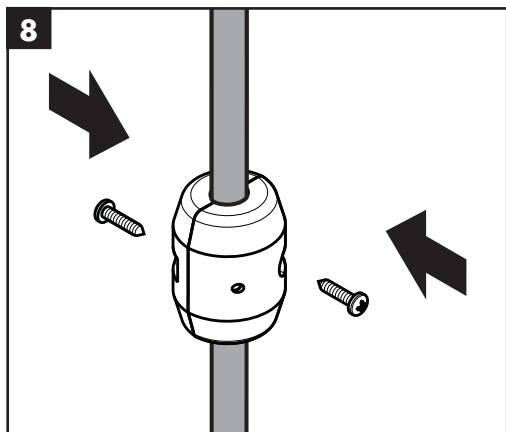
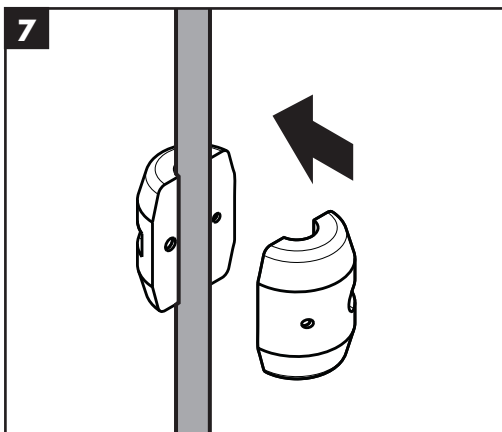
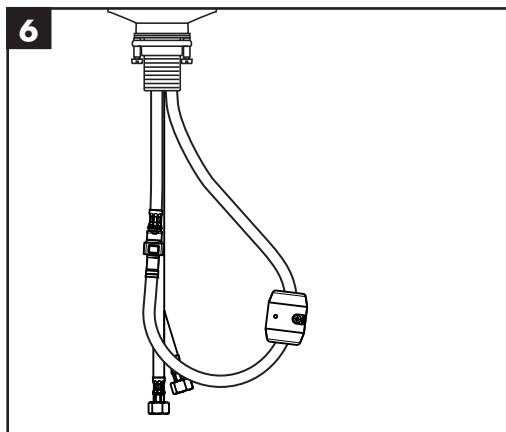

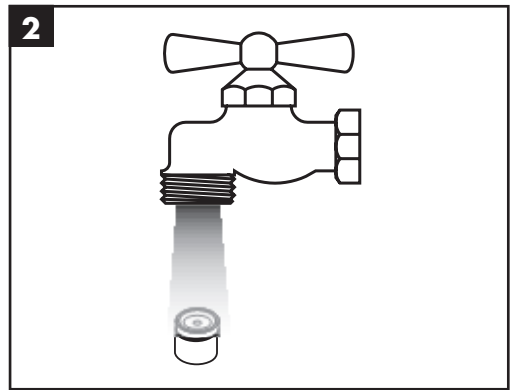
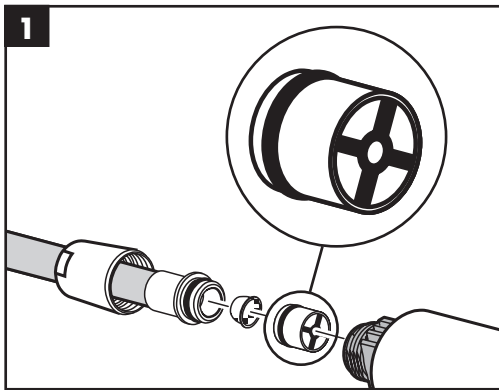
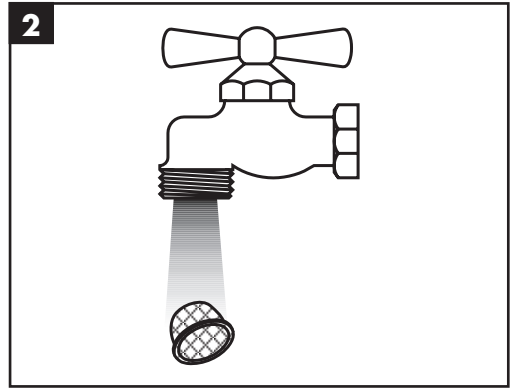
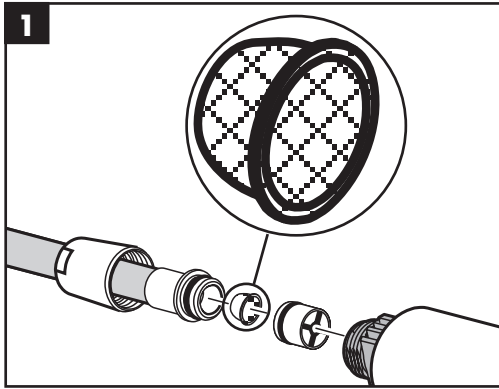

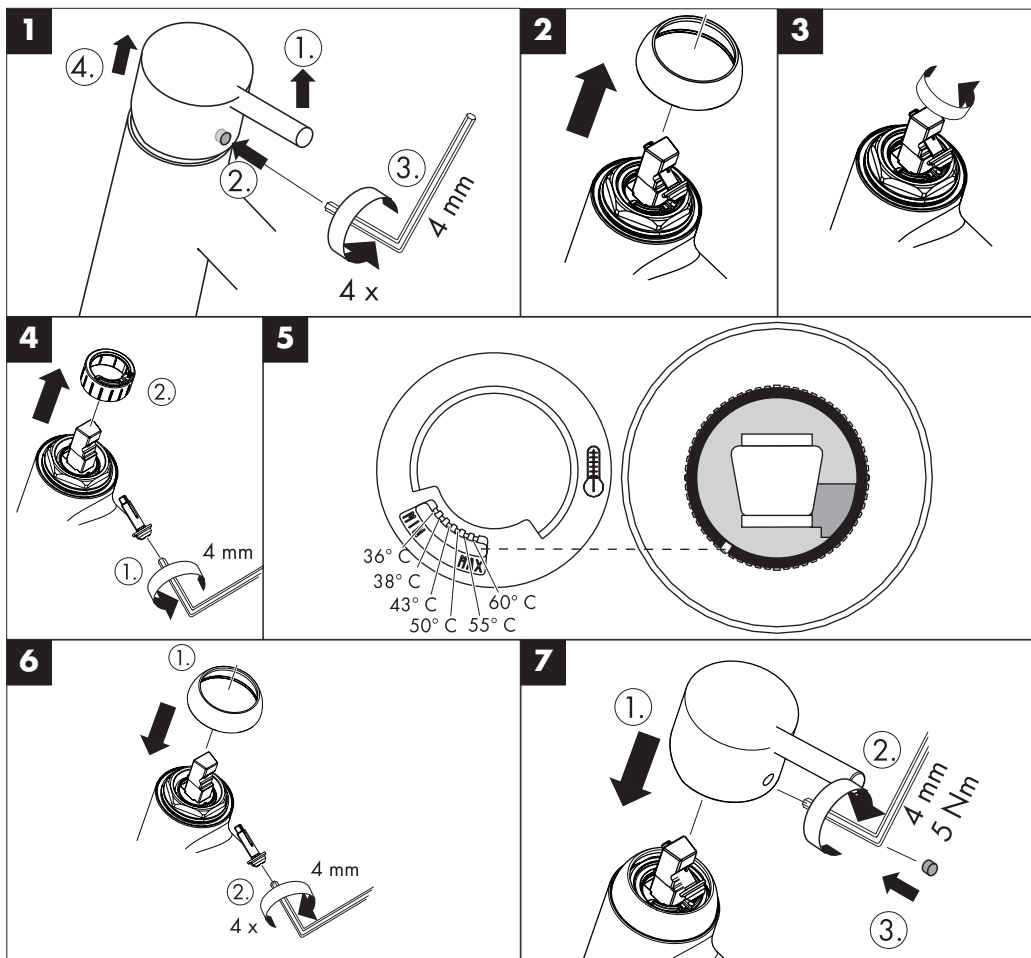

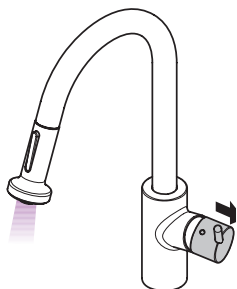

öffnen / ouvert / open / aperto / abierto / open / åbne /
 abrir / otworzyć / otevřít / otvorit / 开 / открыть / nyitás /
 avaaaminen / öppna / atidaryti / Отваранје / açmak /
 deschide / ανοικτό / فتح / odpreti / avage / atvērt /
 otvoriti / árne / отварање / hare

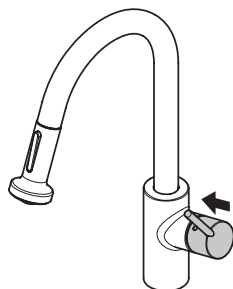

schließen / fermé / close / chiudere / cerrar / sluiten /
 lukke / fechar / zamknąć / zavřít / uzavrieť / 关 /
 закрыть / bezárás / sulkeminen / stänga / uždaryti /
 Zatvaranje / kapatmak / închide / κλειστό / إغلاق /
 zapreti / sulgege / aizvērt / zatvori / lukke / заваряне /
 mbylle



warm / chaud / hot / caldo / caliente / warm / varmt /
 quente / ciepła / teplá / teplá / 热 / горячая / meleg /
 lämmin / varmt / karštas / Vruća voda / sıcak / cald /
 ζεστό / ساخن / toplo / kuum / karsts / topla / varm /
 тепло / i ngrohtë

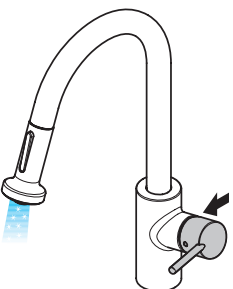

kalt / froid / cold / freddo / frío / koud / koldt / fria /
 zimna / studená / studená / 冷 / холодная / hideg /
 kylmä / kallt / šaltas / Hladno / soğuk / rece / krūo /
 بارد / mrzlo / külm / auksts / hladno / kaldt / студено /
 i ftohtë

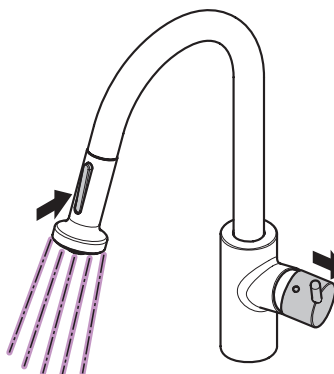

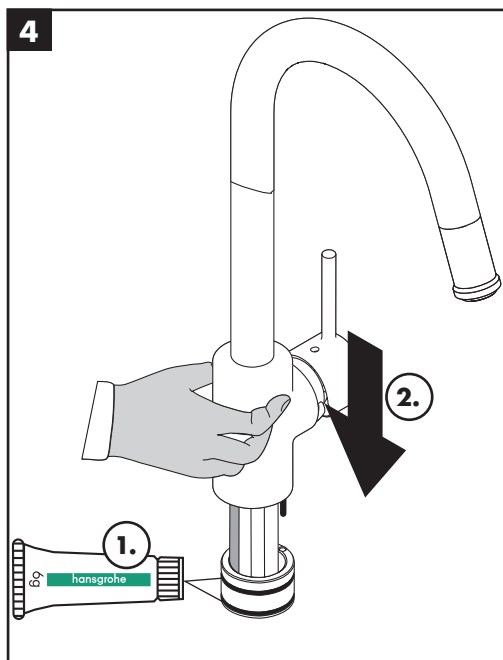
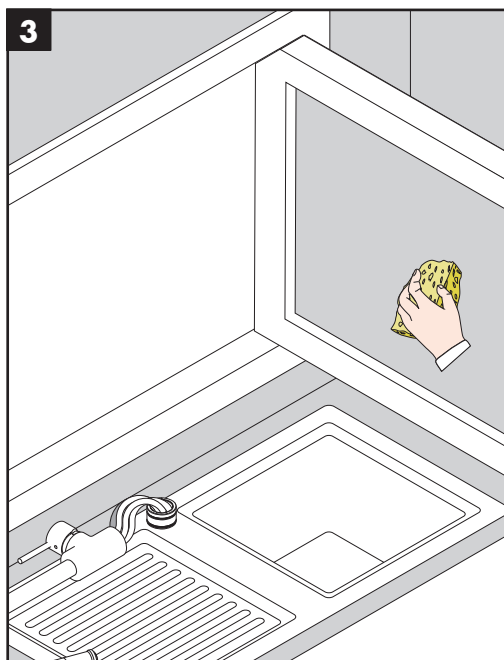
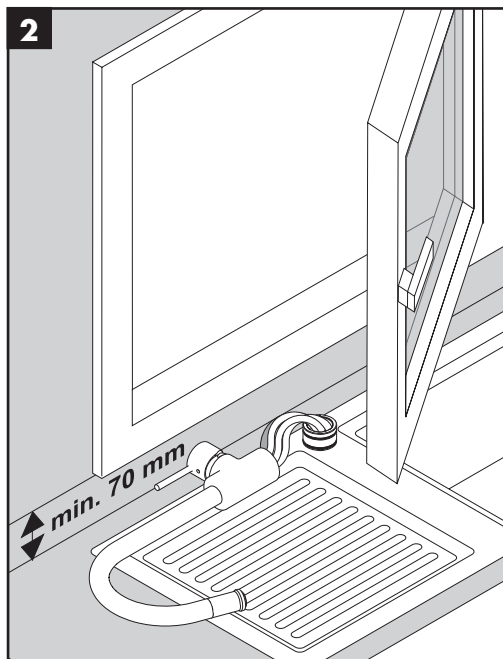
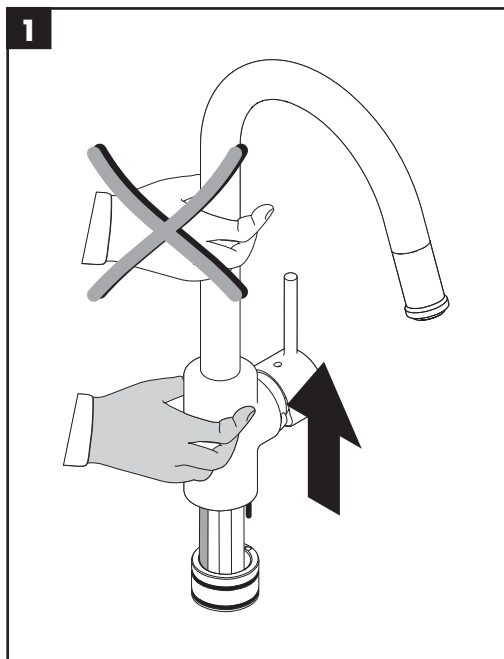



XXX = Farbcodierung / Couleurs / Colors / Trattamento /
Acabados / Kleuren / Overflade / Acabamentos /
Kody kolorów / Kód povrchové úpravy /
Farebné označenie / 颜色代码 /
Цветная кодировка / Színkódolás / Värrikoodaus /
Färgkodning / Spalvos / Boje / Renkler /
Coduri de culori / Χρώματα / نوانوالا / Barve /
Värvid / Krāsu kodi / Oznake boja / Fargekode /
Цветово кодиране / Kodimi me anë të ngjyrave

000 = chrom / chromé / chrome plated / cromato /
cromado / verchromd / Krom / cromado /
chróm / 镀铬 / хром / króm / kromi / krom /
crom / Επιχρωμιωμένο / مورك / kroom / hroma /
hrom / хром

800 = edelstahl-optik / aspect acier inox /
stainless steel optic / acciaio inox acciaio /
acero especial / RVS-look / Stainless steel optic /
aço imaculado ótica / stal szlachetna /
nerezová ocel / nerezova ocel / 不锈钢表面 /
сталь / acéloptika / inox-optinen / rostfri-optik /
plienas / plemeniti čelik / paslanmaz çelik - optik /
otel inox / οπτική ανοξειδωτου χαλυβα /
مظهر الإستليس ستيل /
videz legiranega jekla /
roostevaba optik / tērauda /
dezen plemeniti čelik /
rustfritt stål optikk /
оптика на благородна стомана /
optikë çeliku

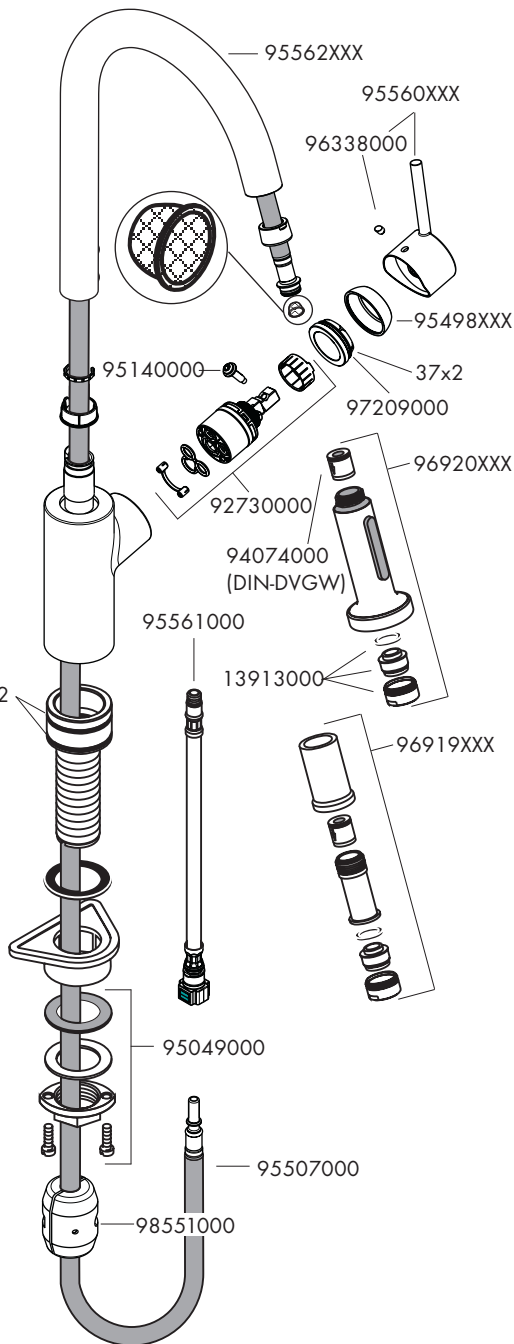
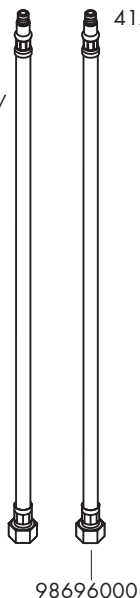





| | PA-IX | DVGW | SVGW | ACS | WRAS | KIWA | ETA |
|-----------------|---------------|-------------|-------------|------------|-------------|-------------|--------------|
| 14872XXX | P-IX 9537/IB | | X | X | X | X | VD1.42/17815 |
| 14877XXX | P-IX 9538/IBO | | X | X | | X | VD1.42/17815 |



14872XXX



14877XXX