

Arbeiten an den elektrischen Anlagen dürfen nur von autorisierten Fachleuten nach den örtlichen Vorschriften ausgeführt werden. Für nicht fachgerechte Installation wird jegliche Haftung abgelehnt.  
 Räume mit Badewanne oder Dusche müssen mit einer FI-Schutzeinrichtung (RCD) I Δ n = 30 mA gesichert sein. Bereich ② mindestens Schutzart IP X4. Bereich ② keine Steckdosen.



Les travaux à l'installation électrique ne doivent être effectués que par des spécialistes autorisés selon les prescriptions locales. Si l'installation n'est pas faite par un expert nous déclinons toute responsabilité.  
 Locaux avec baignoire ou douche doivent être protégés par un dispositif de protection FI (RCD) I Δ n = 30mA. Volume ② min. degré de protection IP X4. Volume ② des prises électriques ne sont pas permis.

Electric installation work may only be carried out by approved specialists according to the local regulations. Liability will only be accepted by us when our products are installed by qualified engineers.  
 Rooms with bath or shower have to be protected with residual-current-operated protective device (RCD) FI I Δ n = 30mA. Volume ② min. protection IP X4. Volume ② no socket admitted.

ⓐ CH SEV NIN 2005 1000 - 7.01

ⓐ DE VDE 0100 - 701

ⓐ GB BS 7671 - 601

ⓐ NL NEN 1010



Dieses Produkt ist nach den aktuellen Richtlinien geprüft.



Ce produit est examiné selon les directives actuelles.

The product is controlled after current guidelines.

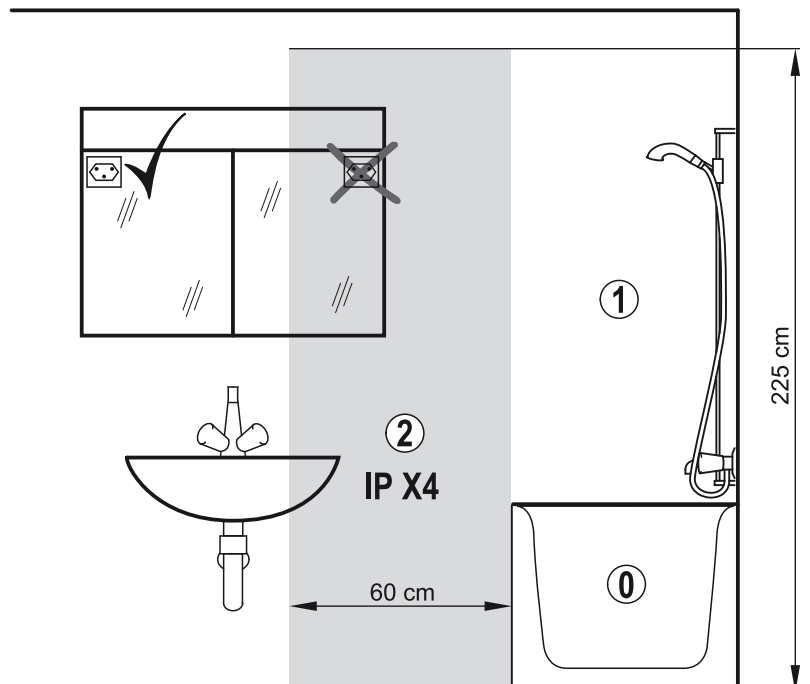

**Montage-Anleitung**  
**Instructions de montage**  
**Assembling instructions**

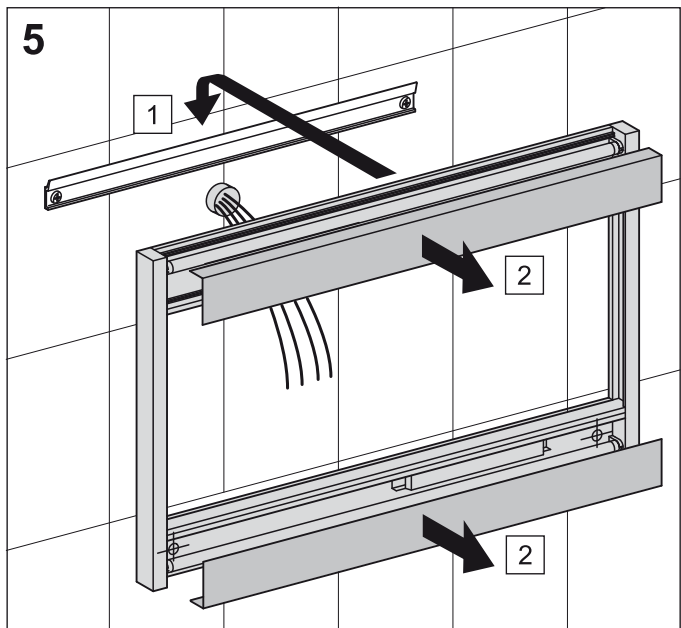
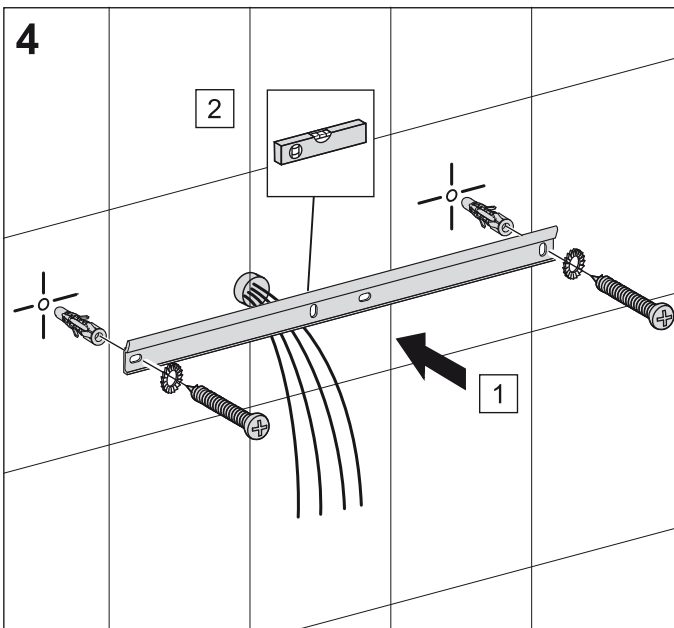
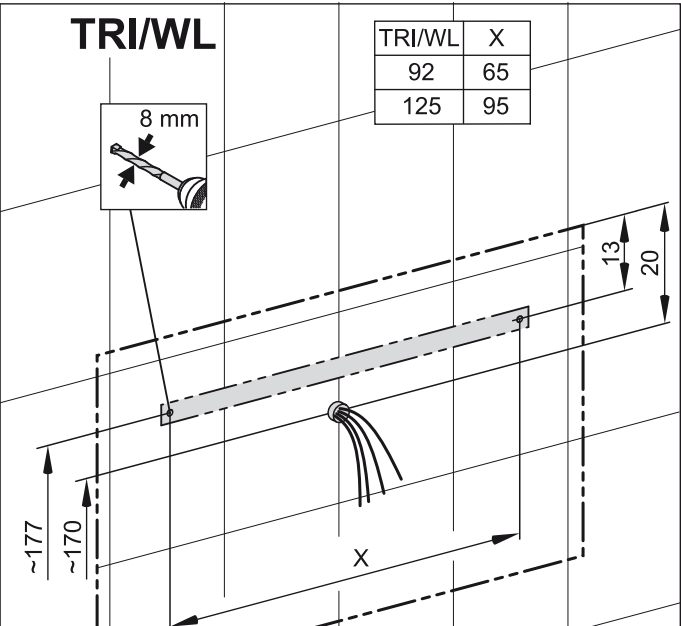
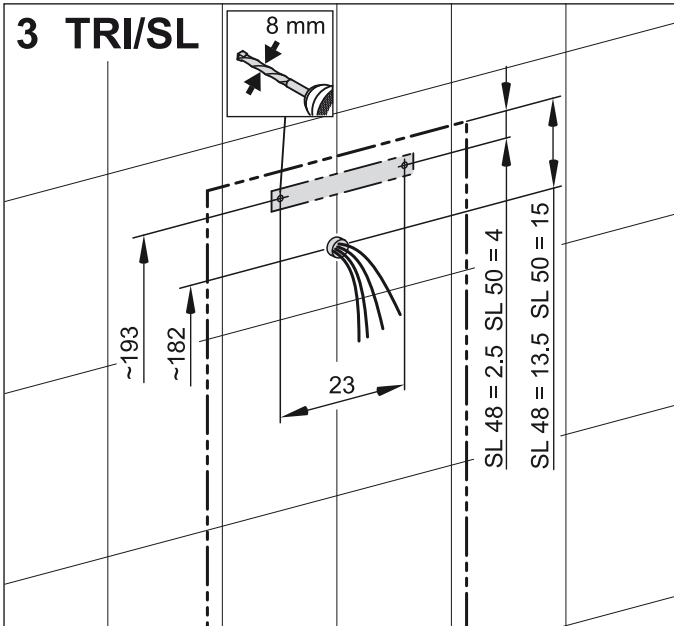
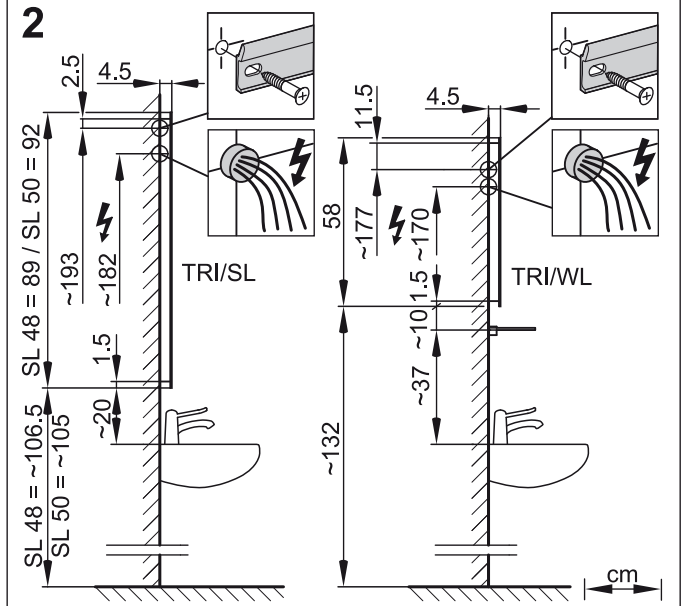
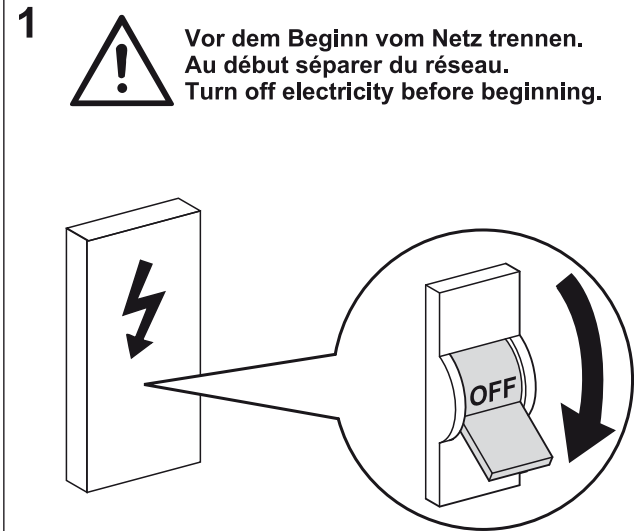

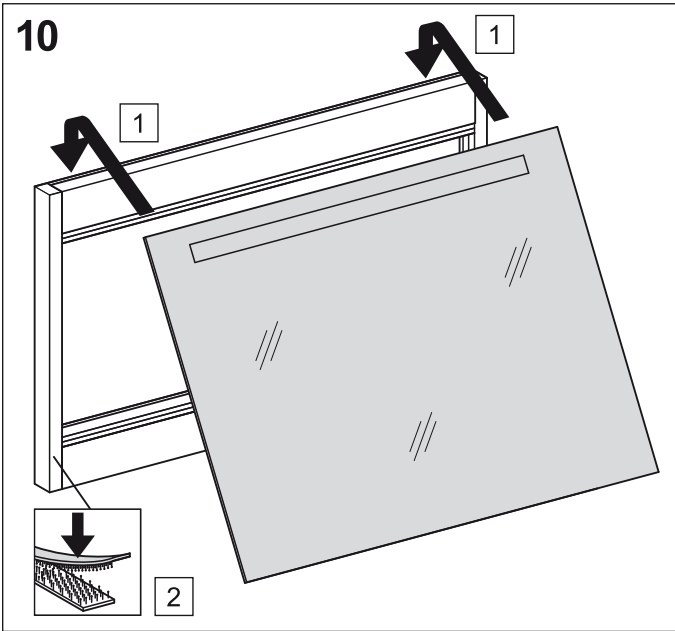
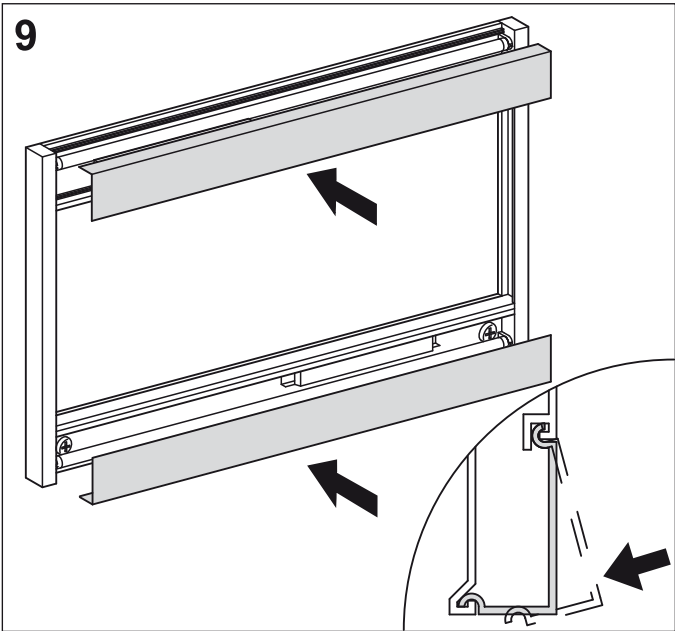
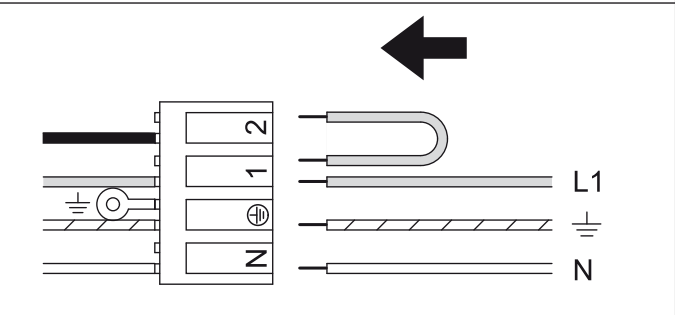
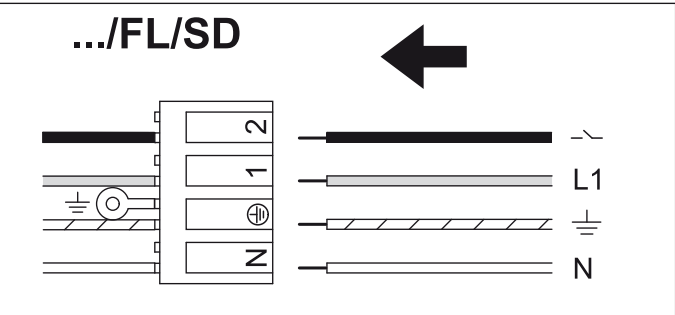
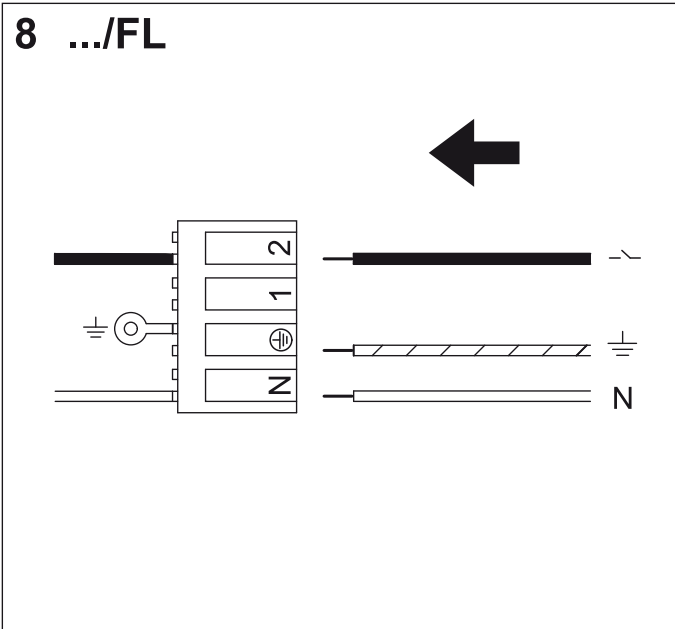
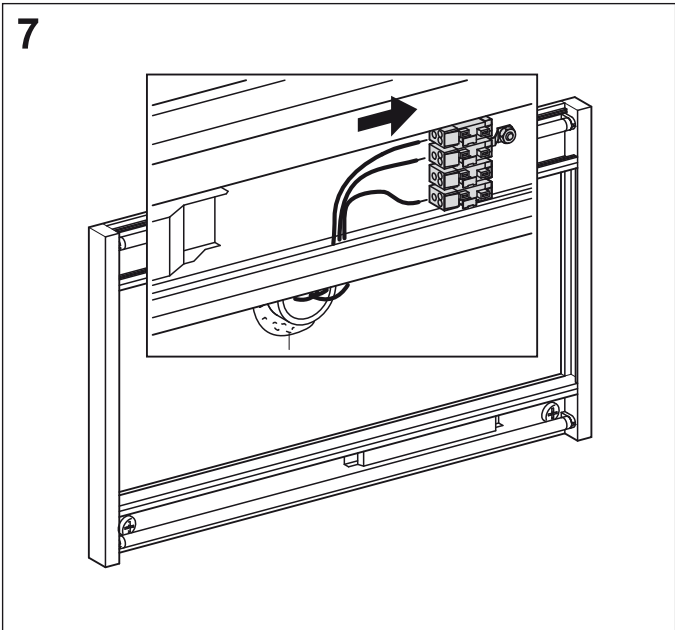
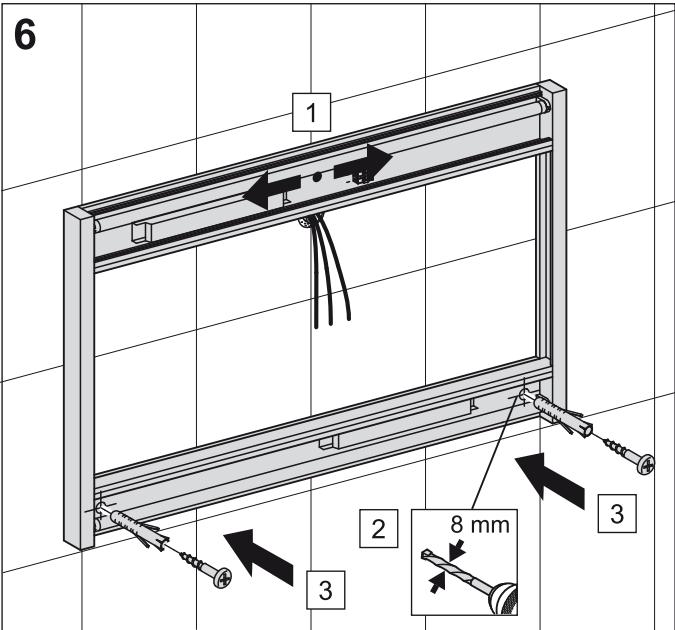

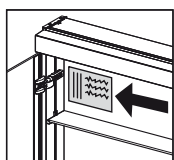
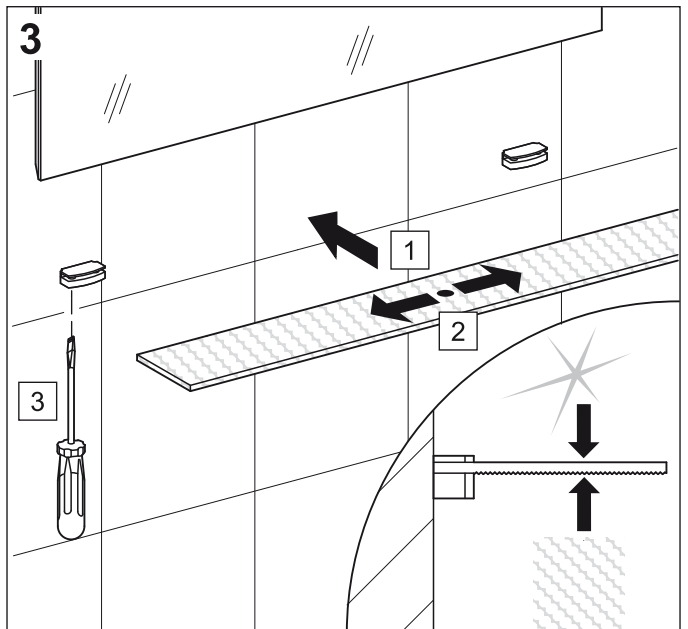
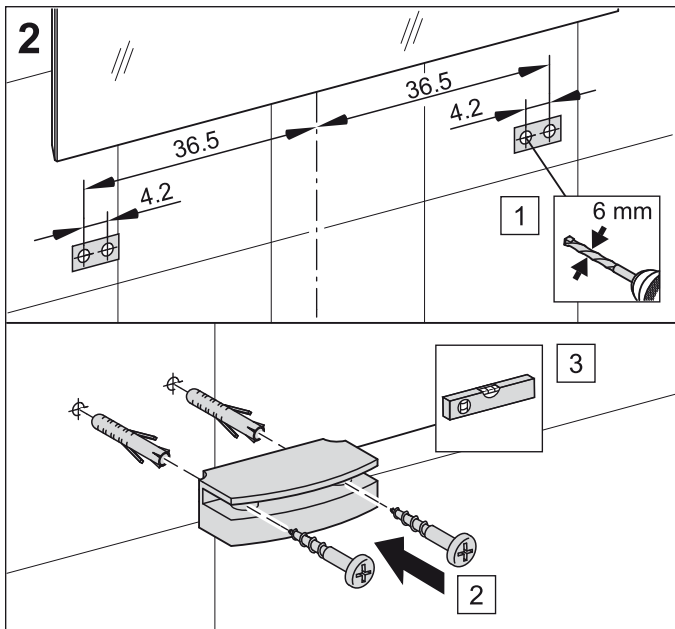
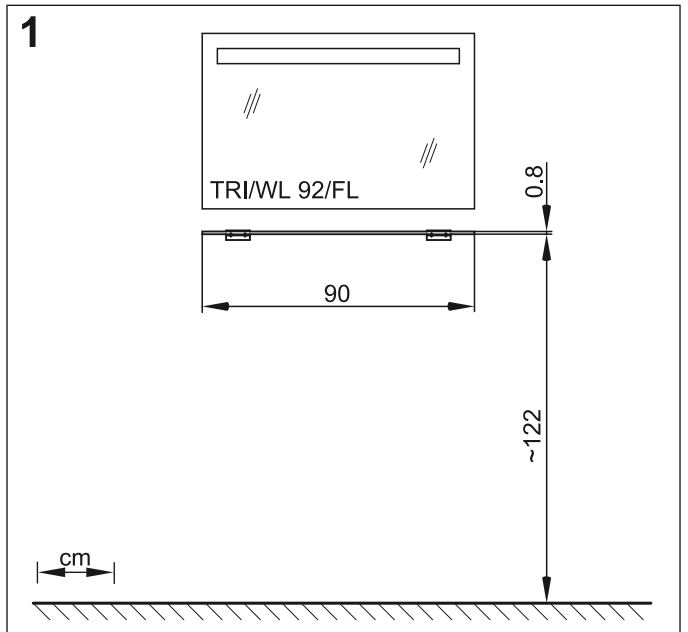
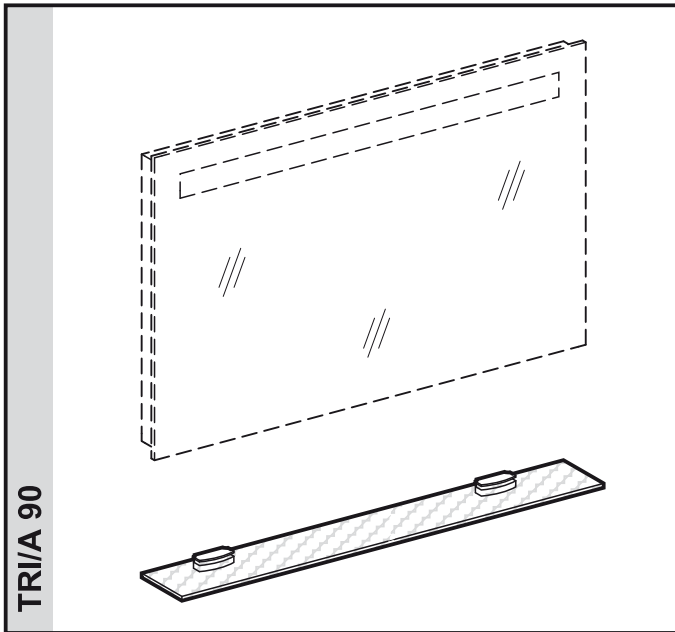

Pflegehinweis beachten.  
 Observez le conseils d'entretien.  
 Follow care tips.

TRI/PKL IP24

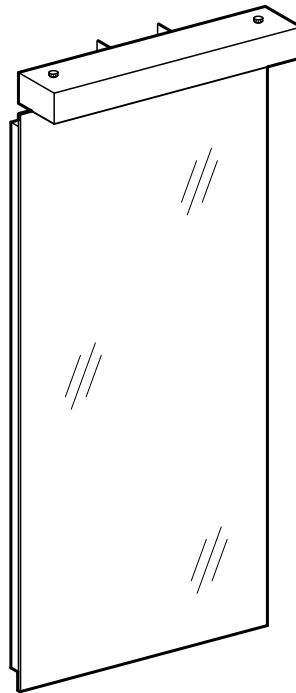

Arbeiten an den elektrischen Anlagen dürfen nur von autorisierten Fachleuten nach den örtlichen Vorschriften ausgeführt werden. Für nicht fachgerechte Installation wird jegliche Haftung abgelehnt.  
Räume mit Badewanne oder Dusche müssen mit einer FI-Schutzeinrichtung (RCD) I  $\Delta n = 30 \text{ mA}$  gesichert sein.

Les travaux à l'installation électrique ne doivent être effectués que par des spécialistes autorisés selon les prescriptions locales. Si l'installation n'est pas faite par un expert nous déclinons toute responsabilité.  
Locaux avec baignoire ou douche doivent être protégés par un dispositif de protection FI (RCD) I  $\Delta n = 30 \text{ mA}$ .



Electric installation work may only be carried out by approved specialists according to the local regulations. Liability will only be accepted by us when our products are installed by qualified engineers.  
Rooms with bath or shower have to be protected with residual-current-operated protective device (RCD) FI I  $\Delta n = 30 \text{ mA}$ .

**CH** SEV NIN 2005 1000 - 7.01

**DE** VDE 0100 - 701

**GB** BS 7671 - 601

**NL** NEN 1010



Dieses Produkt ist nach den aktuellen Richtlinien geprüft.



Ce produit est examiné selon les directives actuelles.

The product is controlled after current guidelines.

**Montage-Anleitung**  
**Instructions de montage**  
**Assembling instructions**

**1**  **Vor dem Beginn vom Netz trennen.**  
**Au début séparer du réseau.**  
**Turn off electricity before beginning.**

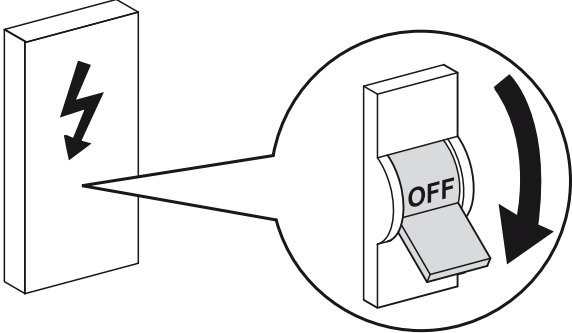

**2**

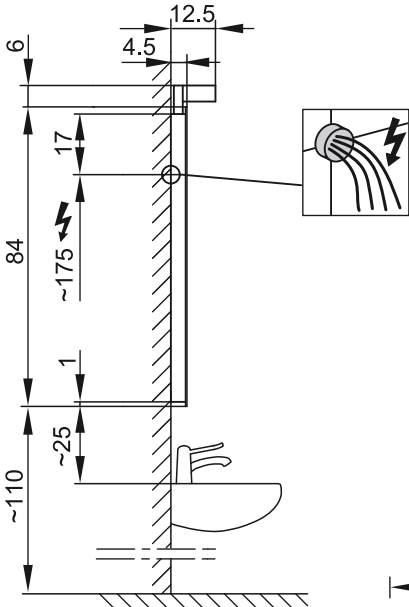

| cm |

**3**

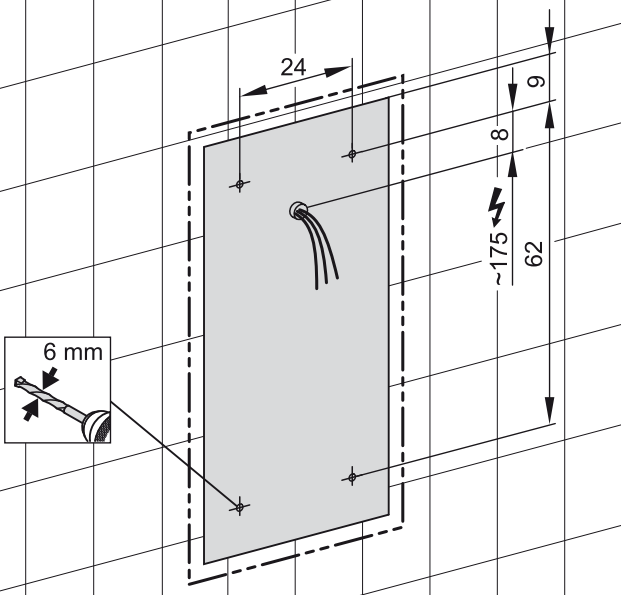

6 mm

**4**

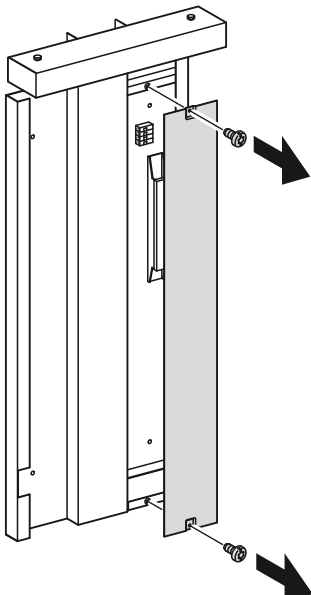

**5**

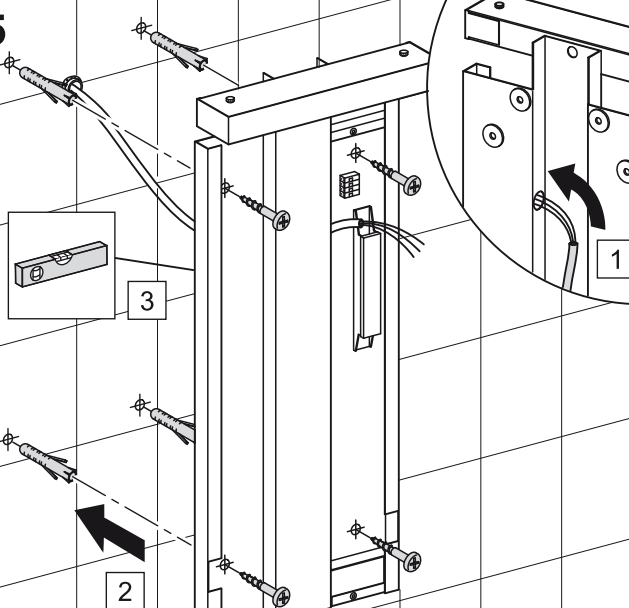

3

2

1

**6**

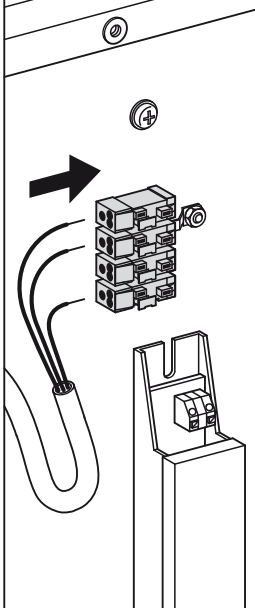

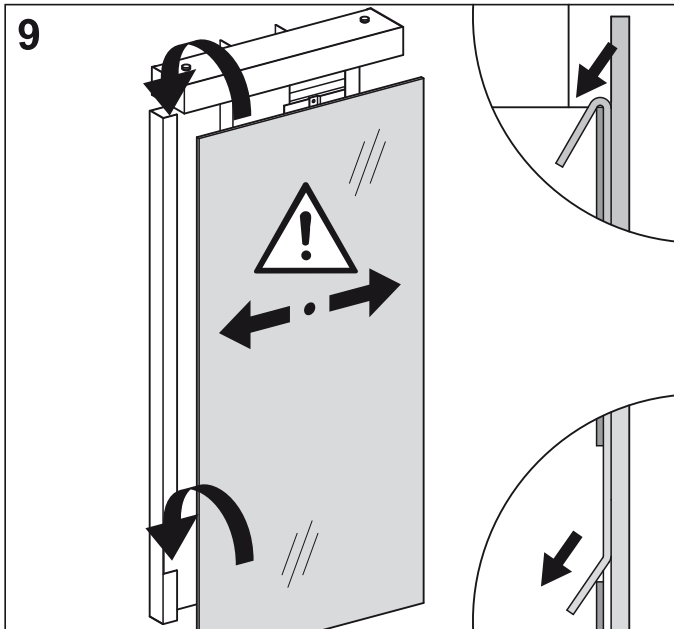
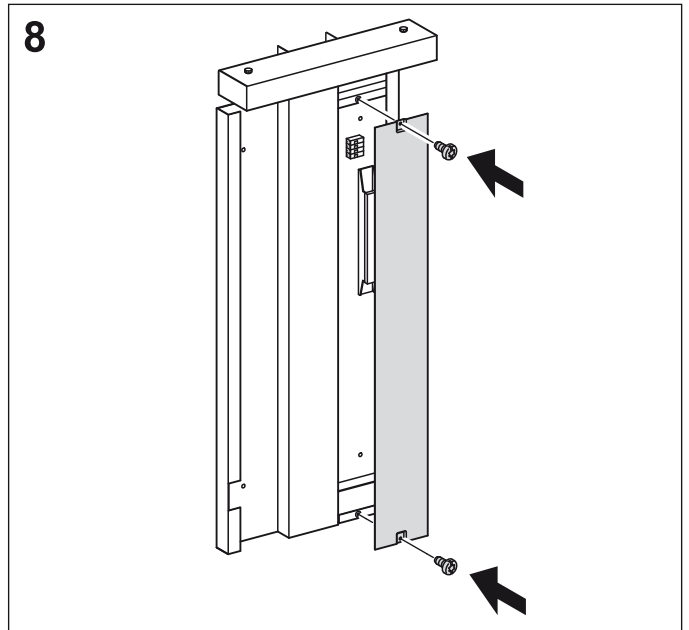
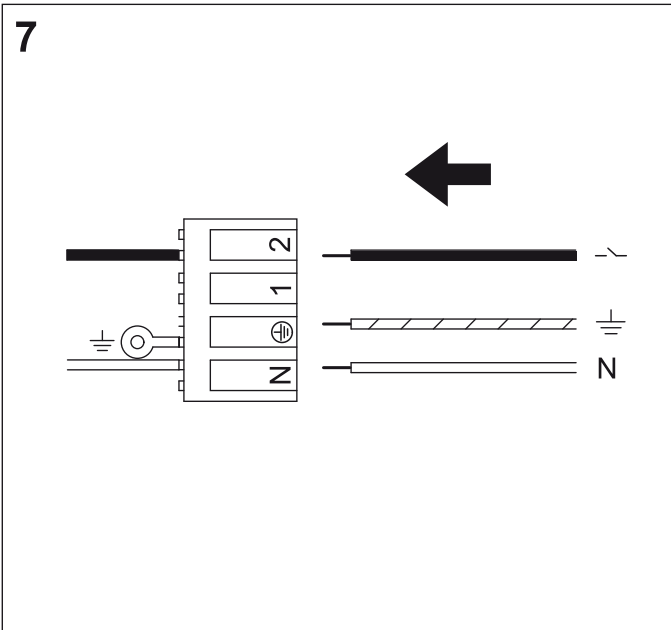

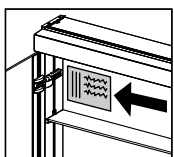

Pflegehinweis beachten.  
Observez le conseils d'entretien.  
Follow care tips.